

AEPA Bid Checklist

Proposal: IFB 020-E Lawn & Groundskeeping Equipment, Supplies & Services

Awarded Vendor(s): Bobcat & Husqvarna

Award Date: January 6-15, 2020 **Contract Number:** 020-E

- Copy of Public Notice
- Copy of Bid Specifications
- Opening Record/List of Bids Received
- Copy of Bids Received
- Recommendation for New Contracts
- Tally Sheets with Notes/Executive Summary
- Copy of Signed Contract(s)
- Board Acceptance of Bid

AFFIDAVIT OF PUBLICATION

STATE OF MINNESOTA .)
COUNTY OF HENNEPIN)



650 3rd Ave. S, Suite 1300 | Minneapolis, MN | 55488

Terri Swanson, being first duly sworn, on oath states as follows:

1. (S)He is and during all times herein stated has been an employee of the Star Tribune Media Company LLC, a Delaware limited liability company with offices at 650 Third Ave. S., Suite 1300, Minneapolis, Minnesota 55488, or the publisher's designated agent. I have personal knowledge of the facts stated in this Affidavit, which is made pursuant to Minnesota Statutes §331A.07.

2. The newspaper has complied with all of the requirements to constitute a qualified newspaper under Minnesota law, including those requirements found in Minnesota Statutes §331A.02.

3. The dates of the month and the year and day of the week upon which the public notice attached/copied below was published in the newspaper are as follows:

<u>Dates of Publication</u>	<u>Advertiser</u>	<u>Account #</u>	<u>Order #</u>
StarTribune 07/22/2019	LAKES COUNTRY SERVICE COOPERATIVE	1000301188	318152
StarTribune 07/29/2019	LAKES COUNTRY SERVICE COOPERATIVE	1000301188	318152

4. The publisher's lowest classified rate paid by commercial users for comparable space, as determined pursuant to § 331A.06, is as follows: **\$739.20**

5. Mortgage Foreclosure Notices. Pursuant to Minnesota Statutes §580.033 relating to the publication of mortgage foreclosure notices: The newspaper's known office of issue is located in Hennepin County. The newspaper complies with the conditions described in §580.033, subd. 1, clause (1) or (2). If the newspaper's known office of issue is located in a county adjoining the county where the mortgaged premises or some part of the mortgaged premises described in the notice are located, a substantial portion of the newspaper's circulation is in the latter county.

FURTHER YOUR AFFIANT SAITH NOT.

Terri Swanson

Subscribed and sworn to before me on: 07/29/2019

Jalene K. Howard

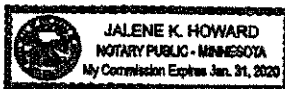

Notary Public



Classified Advertising Invoice

Bismarck Tribune

PO BOX 540
Waterloo, IA 50704-0540

888-418-6474

LAKES COUNTRY SERVICE COOP
Lori Mittelstadt
1001 E MOUNT FAITH
FERGUS FALLS MN 56537

Customer: 60058870
Phone: (218) 737-6535
Date: 08/05/2019

CREDIT CARD PAYMENT (circle one)



Card #: _____
Exp Date: _____
Signature: _____
Credit card users: Fax to 319-291-4014

Date	Order #	Type	Order Amt
08/05/19	20977625	INV	153.90

Amount Paid	CK #:
_____	_____

PLEASE DETACH AND RETURN TOP PORTION WITH YOUR PAYMENT

Lee Enterprises no longer accepts credit card payments sent via e-mail. Emails containing credit card numbers will be blocked. Please use the coupon above to send a credit card payment to remittance address located in the upper right corner. You may also send the coupon to a secure fax at 319-291-4014.

Date	Date	Times Run	Description	Lines	Class C	mt Due
			September 16, 2019 - For Bids:	57.00	Legals	153.90
07/22/19	08/05/19	3	Bismarck Tribune PO: Lisa Truax			

Affidavit of Publication
State of North Dakota) SS County of Burleigh
Before me, a Notary Public for the State of North Dakota personally appeared JL who being duly sworn, deposes and says that he (she) is the Clerk of Bismarck Tribune Co., and that the publication(s) were made through the Bismarck Tribune on the following dates: 7/22, 29 & 8/5. Signed [Signature] sworn and subscribed to before me this 8 day of Aug 2019.
Tasha L Williams
Notary Public in and for the State of North Dakota

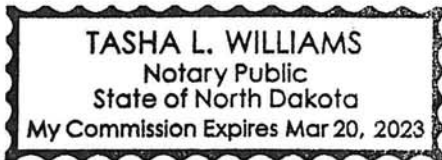

Notice to Bidders
Sealed Bids will be received by the Association of Educational Purchasing Agencies (AEPA) on behalf of its Member Agencies until:

1:30 p.m. EST, Monday,
September 16, 2019

For Bids: 020-A Natural and Synthetic Surfaces for Sport Fields, Tracks, Courts, Playground and Landscaping Applications, 020-B Carpet & Resilient Flooring, 020-C Digital Resources & Instructional Materials, 020-D Facility Management Software, 020-E Lawn & Groundskeeping Equipment, Supplies & Services, 020-F Digital Display Solutions, and 020-G Vehicles - Cars, SUVs, Cross-overs, Light Duty Trucks, Vans, Police and Public Safety.

Each bid package consists of multiple parts:
Part A - Terms and Conditions
Part B - Specifications
Part C - Member Agency (State) Terms and Conditions
Part D - Questionnaire
Part E - Signature Forms
Part F - Discount and Pricing Schedule Workbook

All bids shall be submitted online via Public Purchase by the due date and time listed above. Note that Bidders must be able to provide their proposed products and services in up to 28 states including California, Colorado, Connecticut, Florida, Georgia, Illinois, Indiana, Iowa, Kansas, Kentucky, Massachusetts, Michigan, Minnesota, Missouri, Montana, Nebraska, New Jersey, New Mexico, North Dakota, Ohio, Oregon, Pennsylvania, Texas, Virginia, Washington, West Virginia, Wisconsin and Wyoming.

AEPA bid documents can be downloaded after registering, at no cost, on Public Purchase at www.publicpurchase.com. AEPA and/or the respective Member Agencies reserve the right to reject any or all bids in whole or in part; to waive any formalities or irregularities in any bids, and to accept the bids, which in its discretion, within state law, are for the best interest of any of the AEPA Member Agencies and/or their Participating Entities. Bids will be opened and an opening record will be posted to Public Purchase. Bids will be publicly opened at 1:30 PM EST on September 16, 2019, at Oakland Schools, 2111 Pontiac Lake Road, Waterford, MI 48328.

7/22, 29 & 8/5 - 20977625

Please return invoice or put order number on check. Thank You.

Remarks

Bismarck Tribune
www.bismarcktribune.com
PO BOX 540
Waterloo, IA 50704-0540

Terms: PAYMENT IS DUE UPON RECEIPT OF INVOICE

153.90

From: [Public Purchase](#)
To: [Jane Eastes](#)
Cc: [Ted M Witt](#); [Rob Naughton](#); [Stephanie Brown](#); [Elmo Kallner](#); [Larche Hardy](#); [David Mahalko](#); [Tina Smith](#); [Robin Strauser](#); [Anna Marie Andrew](#); [George Wilson](#); [Andrew Pickens](#); [Tamra Hurst](#); [Ken Swink](#); [Michelle Pratt](#); [Lisa Truax](#); [Melissa Mattson](#); [Ed M Pabor](#)
Subject: Release Successful on Bid IFB #020-E - Lawn & Groundskeeping Equipment, Supplies & Services
Date: Monday, July 22, 2019 3:02:10 PM

Jane Eastes:

Bid "IFB #020-E - Lawn & Groundskeeping Equipment, Supplies & Services"
Status: Release Successful on Jul 22, 2019 3:01:37 PM CDT

You can check the released bid by going to the following address:
<http://www.publicpurchase.com/gems/bid/bidView?bidId=115756>

If you have any questions regarding this bid, please contact our Customer Support Staff at agency-support@publicpurchase.com

Thank you for using Public Purchase.

MK= 5/zBi8sDOKq6Vbg9Rm+rgQ==

PART A
Instructions and General Terms and Conditions
AEPA IFB #020-E Lawn & Groundskeeping Equipment,
Supplies & Services

Notice to Bidders

Sealed bids will be received by the Association of Educational Purchasing Agencies (AEPA) on behalf of its Member Agencies until:

1:30 p.m. ET, Monday, September 16, 2019

For Bids: 020-A Natural and Synthetic Surfaces for Sport Fields, Tracks, Courts, Playground and Landscaping Applications, 020-B Carpet & Resilient Flooring, 020-C Digital Resources & Instructional Materials, 020-D Facility Management Software, 020-E Lawn & Groundskeeping Equipment, Supplies & Services, 020-F Digital Display Solutions, and 020-G Vehicles – Cars, SUVs, Crossovers, Light Duty Trucks, Vans, Police and Public Safety.

Each bid package consists of multiple parts:

- Part A – Terms and Conditions**
- Part B – Specifications**
- Part C – Member Agency (State) Terms and Conditions**
- Part D – Questionnaire**
- Part E – Signature Forms**
- Part F – Discount & Pricing Workbook**

All bids shall be submitted online via Public Purchase by the due date and time listed above. Note that Bidders must be able to provide their proposed products and services in up to 28 states including California, Colorado, Connecticut, Florida, Georgia, Illinois, Indiana, Iowa, Kansas, Kentucky, Massachusetts, Michigan, Minnesota, Missouri, Montana, Nebraska, New Jersey, New Mexico, North Dakota, Ohio, Oregon, Pennsylvania, Texas, Virginia, Washington, West Virginia, Wisconsin and Wyoming.

AEPA bid documents can be downloaded after registering, at no cost, on Public Purchase at www.publicpurchase.com. AEPA and/or the respective Member Agencies reserve the right to reject any or all bids in whole or in part; to waive any formalities or irregularities in any bids, and to accept the bids, which in its discretion, within state law, are for the best interest of any of the AEPA Member Agencies and/or their Participating Entities. Bids will be opened and an opening record will be posted to Public Purchase. Bids will be publicly opened at 1:30 PM ET on September 16, 2019, at Oakland Schools, 2111 Pontiac Lake Road, Waterford, MI, 48328.

Bid & Contract Timeline:

Monday, July 22, 2019	Release of IFBs
Wednesday, August 14, 2019	Pre-Bid Conference Call (optional)
Friday, August 23, 2019	Deadline for questions from Bidders
Monday, September 16, 2019	Deadline for Bid Submittals and Bid Reading via Public Purchase

Friday, October 25, 2019	Contract Recommendations posted on Public Purchase and the AEPA website, www.aepacoop.org
December 2-4, 2019	AEPA Approval of bids
December 9, 2019	Vendor Partner's submit required documentation to Member Agencies
No later than May 1, 2020, to February 28, 2021	Initial contract term (up to fifteen months) – See Term of Contract and Extensions in General Terms & Conditions
March 1, 2021 - 2024	Annual contract renewal dates subject to approval by AEPA

Part A – Table of Contents

I. ABOUT AEPA.....2

II. BID PROCEDURE4

A. ISSUING AGENCY4

B. QUESTIONS.....5

C. BIDDER QUALIFICATIONS.....5

D. BID SECURITY.....5

E. BID SUBMITTAL.....6

1. *Preparation of the Bid Response*.....6

2. *Document Development*.....6

3. *Bid Transmittal*.....7

F. BID EVALUATION, APPROVAL AND AWARD.....7

G. CONTRACT AWARD AND IMPLEMENTATION.....9

III. RESPONSIBILITIES OF A VENDOR PARTNER9

IV. RESPONSIBILITIES OF AEPA MEMBER AGENCIES10

V. GENERAL TERMS AND CONDITIONS FOR ALL AGENCIES.....10

I. About AEPA

Welcome to The Association of Educational Purchasing Agencies (AEPA) annual bid solicitation. AEPA is a unique school procurement consortium established in 2000, and incorporated in 2007 under the state laws of Nevada. We are consortium of non-profit public agencies representing twenty-eight (28) states. We joined to issue simultaneous Invitations for Bids (IFB) generating sales for vendor partners in forty-nine (49) states. AEPA’s mission is to cooperatively serve our members though a continuous effort to explore and solve present and future purchasing needs. Our goal is to secure multi-state volume purchasing contracts with benefits for our public members that are measurable, cost-effective, and exceed members’ expectations for customer service and value. AEPA is committed to accomplish this mission lawfully and ethically, using leading edge technology and contemporary business practices.

The advantage for vendors to work with AEPA is that you respond to one bid that is legally performed across as many as 28 states, which have the potential to sell nationwide. You are working with up to 28 agencies with a long and trusted history with their public membership. Through our partnerships, AEPA vendors have access to thousands of public agencies across the country. We are a multi-million-dollar procurement group through our current awarded vendors and are growing.

AEPA designates one Member Agency per state that is operating legally under the rules and regulations of that state. Any additional agencies that wish to participate will negotiate with the authorized Member Agency and participate through them in a manner in which they mutually agree is not in conflict with AEPA procedures. The Member Agency will be the only agency allowed to represent that state at AEPA and will be the only communication link between AEPA and that state.

Each Member Agency, along with the awarded Vendor Partner, represents, supports and promotes the AEPA contracts within their respective state. While the consortium was initially created to support educational entities, the Member Agency for each state determines which public entities (higher educational institutions, cities, counties, townships, states, etc.) can utilize the competitively bid contracts (see the Summary of State Participation by Bid Category Table). Participating entities may include Public and Private School Districts, Educational Service Agencies, Intermediate School Districts, Higher Education Institutions, Federal Agencies, State Agencies, Local Public Bodies and Nonprofit Non-Public Corporations, Organizations, other entities contracted to conduct business on behalf of a participating entity provided they are required to follow member state and local procurement regulations, etc. that have authorizations to utilize the AEPA Member Agencies' Awarded Contracts.

AEPA has an elected President, Vice President, Secretary and Treasurer. Operations are overseen by the Executive Director. The AEPA Board representing 28 states meets twice per year, and operates otherwise through a sophisticated committee structure.

AEPA Member Agency Information

State	Agency Name	Contact	Email	Students
California	Monterey County Office of Education d/b/a CalSAVE	Ted Witt	twitt@epylon.com	6,000,000
Colorado	Colorado BOCES Association	John Tillman	jtillman@my.amigo.net	889,000
Connecticut	Capitol Region Education Council (CREC)	Cara Hart	chart@crec.org	538,000
Florida	Panhandle Area Education Consortium	Larche Hardy	larche.hardy@paec.org	2,700,000
Georgia	Cooperative Purchasing Agency	Kevin Benson	kbenson@cpa4schools.com	1,600,000
Indiana	Wilson Education Center	Pam Clover	pclover@wesc.k12.in.us	1,046,026
Illinois	Illinois Learning Technology Purchase Program	Hope Hardin-Borbely	hhardinborbely@iltpp.org	2,001,548
Iowa	AEA Purchasing	Joni Puffett	joni@aeapurchasing.org	510,010
Kansas	Southeast Kansas Education Service Center	Tina Smith	tina.smith@greenbush.org	468,510
Kentucky	Green River Regional Educational Cooperative	Ann Burden	ann.burden@grrec.org	675,000
Massachusetts	The Education Cooperative	Joan Preble	jpreble@tec-coop.org	955,739
Michigan	Oakland Schools	Tim Loock	tim.loock@oakland.k12.mi.us	1,550,802
Minnesota	Cooperative Purchasing Connection	Jeremy Kovash	jkovash@lcsc.org	842,932
Missouri	EducationPlus	Steve Griggs	sgriggs@edplus.org	885,204
Montana	Montana Cooperative Service	Dave Puyear	dpuyear@mrea-mt.org	144,129
Nebraska	Nebraska ESU Cooperative Purchasing	Craig Peterson	Craig.peterson@esucc.org	300,000
New Jersey	Middlesex Regional Educational Services Commission	Pat Moran	pmoran@mresc.k12.nj.us	1,369,000
New Mexico	Cooperative Educational Services	Dotty McKinney	dotty@ces.org	338,307
North Dakota	North Dakota Educators Service Cooperative	Jane Eastes	jeastes@lcsc.org	106,863
Ohio	Ohio Council of Educational Purchasing Consortium	Elmo Kallner	elmo.kallner@epcschools.org	1,700,000
Oregon	Intermountain ESD	Rob Naughton	rob.naughton@imesd.k12.or.us	570,857

Pennsylvania	Central Susquehanna Intermediate Unit d/b/a Keystone Purchasing Network	Jeff Kimball	jkimball@csiu.org	5,700,000
Texas	Region 16 Education Service Center d/b/a TexBuy	Andrew Pickens	andrew.pickens@esc16.net	5,232,065
Virginia	Fairfax County Public Schools	Michelle Pratt	MRPratt@fcps.edu	1,249,000
Washington	King County Directors Association	Dave Mahalko	dmahalko@kcda.org	1,000,000
West Virginia	Mountain State Educational Services Cooperative	Jan Hanlon	jhanlon@k12.wv.us	289,899
Wisconsin	Cooperative Educational Service Agency (CESA) #2	Jane Wray	jane.wray@cesa2.org	873,000
Wyoming	Northeast Wyoming Board of Cooperative Educational Services	Nita Werner	nwerner@newboces.com	91,000

II. Bid Procedures

A. Issuing Agency

The great benefit to the Bidder is that one response may be prepared for approval by AEPA and awarded by multiple AEPA Member Agencies and utilized by their Participating Entities located throughout many states. Bidders responding to this IFB will submit their response in the required formats (PDF, Word, Excel) of all files requested along with complete catalogs via Public Purchase, a free online bidding platform, by the due date and time of this IFB. Bidders selected in response to this single IFB have the potential to provide products and services to local education agencies serving over 36,000,000 (excludes non-represented AEPA states) students.

Each AEPA Member Agency will individually publish notice of the IFB. Bidders will submit their response online, electronically via Public Purchase (www.publicpurchase.com). Responses will be evaluated by bid category committees comprised of AEPA Member Agencies representatives who have indicated they will participate in the category of products and services being solicited, and after AEPA approval, individual AEPA Member Agencies may award contracts to the AEPA Approved Vendor Partners or reject their offers.

The procurement activities of AEPA are limited to document preparation, distribution of the IFB, initial evaluation, and recommendation for possible approval to AEPA Member Agencies. AEPA consists of agency officials who have agreed to assist one another in meeting the public purchasing needs of local school districts and other political subdivisions.

Contracts awarded through cooperative purchasing must meet the procurement laws of the states of each AEPA Member Agency. When these laws are satisfied, an individual entity using these contracts is deemed in compliance with bidding regulations. As allowed by specific state statutes, they can issue purchase orders for any amount without the necessity to prepare their own IFB, Request for Proposal (RFP), or Request for Quotations (RFQ). This saves the entity time and allows for economical and efficient purchasing.

AEPA requires that Bidders only respond if they are able to offer prices equal to or better than what they ordinarily offer to individual entities or cooperatives with equal or lesser volume. State laws that permit or encourage cooperative purchasing contracts do so in the belief that it saves the participants both time and money. Time is saved by having access to volume discounted contracts publicly solicited and being able to purchase what is needed without having to wade through the solicitation process (write solicitation, advertise the IFB, open each response, evaluate and make a selection). Money is saved in procurement cost and lower prices will be the result of volume purchasing. Therefore, a contract issued by a cooperative can be used by hundreds of separate political units; but if it has the same or higher prices than what a single agency or state contract can get through its own bid, a cooperatively bid contract may not be attractive to these members. We request that bidders respond with an advantageous package so that together we can attract members to prefer the cooperatively awarded contract.

The AEPA policy for membership permits new agencies to become AEPA Member Agencies upon approval of existing members. If additional Agencies are added, they and their members may procure from existing contracts upon approval of the awarded Vendor Partners and in accordance with their state laws.

B. Questions

All questions from Bidders must be submitted online through Public Purchase, AEPA will not accept questions in any other format during the bid process. All questions received during the IFB process will be available via Public Purchase. All Bidders will be automatically notified through email when AEPA responds to a question asked by a Bidder. It is the Bidders responsibility to check Public Purchase for any questions and answers prior to the bid deadline. Questions received after the question deadline date will not be answered.

Should AEPA issue an addenda during the solicitation process, all Bidders will be automatically notified through email of the released addenda. AEPA is not responsible for Bidders not acknowledging the issued addenda and not submitting a response according to those changes.

Questions regarding this IFB after Bid Opening, but prior to the approval of the contract, should be submitted to questions@aepacoop.org.

Questions regarding this IFB after Notification of Approval should be submitted to bid-committee@aepacoop.org.

C. Bidder Qualifications

An essential part of the bid evaluation process is an evaluation to qualify the company being considered. All bids must contain answers, responses and/or documentation to the information requested in the Bid Documents. Any Bidder failing to provide the required information/documentation may be considered non-responsive, this includes submitting a response not in the proper format.

Bidders, within their response, must demonstrate their ability, capacity and available resources to provide the proposed products and services to 90% of the AEPA Member Agencies indicating an interest in participating in the categories being solicited, unless otherwise noted in Part B – Technical Specifications of the category being bid. The Bidders are required to communicate and demonstrate within their response they have extensive knowledge, background and at least five (5) years of experience with manufacturing, obtaining, delivering, installing, maintaining and/or supporting the product lines of products, equipment, services or software offered. AEPA and/or its Member Agencies reserve the right to accept or reject newly formed companies or companies failing to demonstrate their abilities or capacity solely based on information provided in the bid response and/or its own investigation of the company.

D. Bid Security

If required, bids shall be accompanied by a satisfactory bid security. This will vary by category and will be noted in Part B, Technical Specifications.

If a bid security is required, a hard copy of the bid security must be in the actual possession of AEPA at Oakland Schools, 2111 Pontiac Lake Road, Waterford, MI 48328, on or prior to the exact due date and time. Original copies of the bid security, must be submitted in a sealed envelope properly addressed to the Association of Educational Purchasing Agencies, with the Bid Number, Bid Category and Bidder's name and address clearly indicated on the envelope or box. Bid securities received late will not be opened and will be deemed non-responsive.

A bidder must also include a PDF copy of the bid security with their response on Public Purchase. If a Bidder fails to submit a copy of the bid security via Public Purchase and/or fails to submit the bid security by the due date and time, its response shall be deemed non-responsive and will not be considered.

An acceptable bid security will have the principal being the Bidder and the Association of Educational Purchasing Agencies listed as the Agency of Record. Bid Security may be a one-time bid bond underwritten by a surety company licensed to issue bid bonds in the state of Nevada and said surety to be approved in federal circular 570 as published by the United States treasury department or the equivalent in cash or an irrevocable letter of credit from a FDIC financial institution. The bid security shall remain in force for one hundred twenty (120) days of bid opening.

E. Bid Submittal

1. Preparation of the Bid Response

- a. The IFB is published in multiple parts. Part A contains the general terms and conditions that apply to all IFB's in the current series of bids. Part B is the technical specifications for the individual bid commodity. Part C includes specific state terms and conditions. Part D, E and F are to be filled out in their entirety and submitted online via Public Purchase in their required formats with the Bidder's response. Some bid categories may contain additional Parts or Forms. All Forms must be uploaded prior to the published bid due date and time of opening.
- b. All bid responses must be on the forms provided by AEPA for each IFB found in Public Purchase, unless otherwise noted. Bidders will submit all documents, in their required formats, online via Public Purchase by the due date and time of the IFB.
- c. Bid Forms requiring signatures shall be submitted by the person authorized to sign the bid response. Failure to properly sign the bid documents will result in the response being deemed non-responsive.
- d. In case of an error in extension of prices in the bid, unit prices shall govern.
- e. Periods of time, stated as a number of days, shall be in calendar days, not business days.
- f. It is the responsibility of all Bidders to examine the entire IFB package, to seek clarification of any item or requirement that may not be clear, and to check all responses for accuracy before submitting a bid. Negligence in preparing a bid confers no right of withdrawal after due time and date.
- g. The Bidders' ability to follow the bid preparation instructions set forth in this solicitation will also be considered to be an indicator of the Bidders' ability to follow instructions should they receive an award as a result of this solicitation. Any contract between the AEPA Member Agency and a Bidder requires the delivery of information and data. The quality of organization and writing reflected in the bid will be considered to be an indication of the quality of organization and writing which would be prevalent if a contract was awarded. As a result, the bid will be evaluated as a sample of data submission.

2. **Document Development:** Bid forms for this IFB are published in Public Purchase, in Word, Excel and PDF formats. Bidders may download the documents once they are registered with AEPA on Public Purchase. All documents must be titled properly and submitted in their required format as noted in the Bid Proposal Checklist. Bidders must scan and upload all documents to Public Purchase following the Bidder's Proposal Checklist, along with any additional documents or files other than those listed below that may be requested and/or related to the this IFB.

- a. **Part C – Member Agency (State) Terms and Conditions:** Some states require additional documentation and signature forms. Review Part C and submit the required state documents with your bid. Submit all state specific forms as one (1) form in PDF format.
- b. **Part D – Questionnaire:** Complete the form provided. The questionnaire seeks information about the Bidder's pricing structure, service areas, past performance and

commerce processes. The Company Information form provides background information on the Bidder's company. Submit the form as one (1) individual form.

- ***NOTE: An attached letter of line of credit from the Bidder's chief financial institution is required unless the company is publicly traded. If the company is publicly traded, a complete Annual Financial Report from the most recent year is REQUIRED.*** Scan the Letter of Line of Credit and/or Annual Report into a PDF document and title as per the instructions. Alternatively, Bidders may choose to send the Letter of Line of Credit and/or Annual Report by email directly to the AEPA Executive Director, George Wilson, at georgewilson.aepa@outlook.com. The Letter of Line of Credit and/or Annual Report must be received by the Executive Director before the due date and time of the bid opening.
- c. **Part E – Signature Forms:** Complete the form provided. The signature form includes multiple areas where signatures are required. Submit the form as one (1) individual form in PDF format.
 - d. **Part F – Discount & Pricing Schedules Workbook:** Complete the Excel workbook provided. Title the Excel document as per the instructions in Document Development above. Be sure to complete the required tabs as outlined in Part F.
 - **Warranties, Additional Services:** In response to Part F, the Bidder may be asked to provide a price schedule for warranties, or additional services, if applicable. This document is created by the Bidder (it is not provided by AEPA) and should be presented in an Excel workbook and titled as per the instructions in Document Development above.
 - **Additional Discounts:** In response to Part F, the Bidder may select to offer additional discounts/bonuses to AEPA members based on a dollar volume, sizes of orders or other criteria, and must state the formula for arriving at these discounts. This document is created by the Bidder (it is not provided by AEPA) and should be presented in an Excel workbook and titled as per the instructions in Document Development above.
 - e. **Price Lists and/or Catalogs:** For catalog bids, PDFs of the Bidder's most recent published catalog(s) or price lists must be included for catalog bids. Each PDF document must be titled as per the instructions in Document Development above.

3. Bid Transmittal

- a. It is the responsibility of the Bidder to be certain that the bid submittal has been uploaded in its entirety to Public Purchase, on or prior to the exact published due date and time.
- b. If required for the category to which you are responding, a hard copy of the bid security must be in the actual possession of AEPA at Oakland Schools, 2111 Pontiac Lake Road, Waterford, MI 48328, on or prior to the exact due date and time. Failure to submit a copy with the response and to send the official bid security to AEPA will result in the Bidder being deemed non-responsive and will not be considered. Bids and bid securities not meeting the due date and time will not be accepted.
- c. If the designated location for receiving the bid security is closed due to an unforeseen circumstance on the day the bid security is due (due date), the bid security will be due at the same time on the next day the building is open. Responsive bids will be opened and the name of each Bidder and other appropriate information will be posted to Public Purchase and the AEPA website.

- F. **Bid Evaluation, Approval and Award:** Bid responses received will be evaluated in accordance with acceptable standards of cooperative purchasing, set forth in and governed by the Procurement Codes of AEPA Member Agency's states; AEPA by-laws, policies and procedures; AEPA Member Agencies' policies and procedures. Approval of prospective Vendor Partners and recommendation of contracts will be made to the lowest responsive and responsible Bidder utilizing the criteria listed in this bid. Contract awards are made by individual AEPA Member

Agencies.

1. **Responsive Bidder:** A responsive bid reasonably and substantially conforms to all material requirements of the solicitation. Bids must be responsive and approved by AEPA to receive award consideration by AEPA Member Agencies. To be determined responsive, the response must meet all of the requirements below:
 - a. Submitted on time.
 - b. Materially satisfy all mandatory requirements identified throughout the IFB.
 - c. Must substantially conform to all of the specified requirements in the IFB in the judgment of AEPA and its AEPA Member Agency representatives.
 - d. Any deviation from requirements indicated herein must be stated, in writing, and included with the bid submittal. Otherwise, it will be considered that bids are in strict compliance with all requirements, and any successful Bidder will be held responsible therefore.
 - e. Deviations or exceptions stipulated in Bidder's response may result in the bid being classified as non-responsive. Language to the effect that the Bidder does not consider this bid to be part of a contractual obligation will result in that Bidder's response being disqualified. Terms of the IFB that any Bidder considers particularly unwarranted, and to which that Bidder would have to take significant exception in his bid, should be stated clearly and concisely as exceptions and/or deviations.
 - f. In preparing a proposal, the Bidder's inability to follow the proposal preparation instructions set forth in this solicitation and its inability to provide written responses, narratives, requested and support documentation relating to the Bidder's qualifications; abilities; capacity; products; specifications; delivery, installation, setup, maintenance; support services and pricing utilized by AEPA evaluators may result in the Bidder's response to be deemed non-responsive.
2. **Non-responsive Bid:** Any bid that does not conform to all material requirements of the solicitation including, but not limited to: bids received after the deadline; bids that do not contain required items and/or provided in the format required, such as proper and/or signed forms, pricing, catalogs, electronic files; bids that do not contain the proper bid bond where required; failure to meet the specified qualifications, product specifications, stipulated documentation or pricing equal to or better than individual entities or cooperatives with equal or lesser volume. AEPA reserves the right to request documents that do not affect pricing, waive minor irregularities, and/or seek clarification following its Board approved procedures. Bids deemed non-responsive bids will not be considered for approval and award.
3. **Responsible Bidder:** A responsible Bidder is a firm or person with the qualifications, capability and capacity to perform the contract requirements with integrity and reliability, which will assure a good faith performance. AEPA's approval of a Bidder's response will make the Bidder available for consideration to the AEPA Member Agencies for contract award. If a Bidder is approved by AEPA, the AEPA Member Agency reserves the right to determine if said Vendor Partner is responsible in their respective state. Factors to be considered in determining whether the standard of responsibility has been met may include but is not limited to whether a Bidder has:
 - a. Submitted a responsive bid;
 - b. The qualifications stipulated herein that may include but are not limited to adequate financial resources, production or service facilities, personnel, service reputation and experience to make satisfactory delivery of the products, services, or construction, described in the invitation for bids to those AEPA member states who have indicated their participation;
 - c. A demonstrated and documented satisfactory track record of performance in the national market place;

- d. A satisfactory record of integrity and a reputation of responding to and meeting educational institutions' needs, adherence of and compliance with federal, state, local and industry standards, rules, regulations and codes;
- e. Quality and suitability of products and services offered to meet and perform to the specifications, expectations and requirements identified in this bid;
- f. Supplied all necessary information and data in connection with determining whether a Bidder meets the standard of responsibility.

4. Cost Evaluation:

- a. Cost and price schedules conform to and provide the information required in Part B – Technical Specifications of this bid;
- b. Pricing offered that is equal to or better than what they ordinarily offer to individual entities or cooperatives with equal or lesser volume;
- c. Methodology used by AEPA and its AEPA Member Agencies to approve prospective Vendor Partners and award contracts;
- d. Line Item Bid: Lowest responsive, responsible Bidder(s); or
- e. Catalog Bid: Lowest responsive, responsible Bidder(s) is/are determined based on the price evaluation criteria; and by a “Core List” and/or by creating a “Market Basket Study” to compare overall pricing between Bidders. A “Market Basket” is a list of items typically purchased by AEPA Member Agencies and their Participating Entities that represent a cross-section of the types of those items purchased. The selection and quantity of line items evaluated will be at the sole discretion of the AEPA evaluators;
- f. The evaluation committee may consider such factors as life-cycle costs, total cost of ownership, quality, and the suitability of an offering in meeting AEPA members' needs.
- g. Based on the cost evaluation, a recommendation will be made to approve a single Bidder or make a multiple Bidder award.

G. Contract Award and Implementation

An AEPA category committee will perform initial bid response review and evaluation and will prepare and make a recommendation to AEPA for its consideration and approval. Those selected Bidders who are approved by AEPA will then be considered by the individual AEPA Member Agencies for contract award. It should be noted that once AEPA has approved the bid response, a Bidder becomes a “Vendor Partner” for AEPA.

Recommendations for approval by AEPA will be posted to Public Purchase and the AEPA website.

Once the approved Bidders have been notified, it is their responsibility to contact those AEPA Member Agencies (up to 28) who had indicated an interest in participating and send Part C (if applicable), Part D, E and F to each of the participating AEPA Member Agencies. Each AEPA Member Agency will review, evaluate and determine which, if any, it will award contracts to.

The approved Vendor Partner and the AEPA Member Agency will hold final contract negotiations, if necessary, to work out state specific details of contract implementation including:

1. Acquiring additional information and having discussions on how the awarded contract will be executed.
2. Signing the contract with the AEPA Member Agency.
3. Jointly develop marketing strategies and a plan for contract roll-out activities to the AEPA Member Agency's Participating Entities (Advertising, flyers, website access, etc.).
4. Establish how orders will be processed, handled and reported.
5. Contract management: Establish how and by whom the day-to-day contract management will be handled and who will be the AEPA Member Agency's representative.

It is not guaranteed that each AEPA Member Agency will enter into a contract with AEPA approved Vendor Partners. The final decision as to the appropriateness of a contract for a Member Agency rests solely with that AEPA Member Agency.

III. Responsibilities of A Vendor Partner

A. As an approved AEPA Vendor Partner, the following is expected in support of the contract:

1. Designate and assign a dedicated senior-level contract manager (one authorized to make decisions) to each of the Member Agency accounts. This employee will have a complete copy and must have working knowledge of the contract.
2. Train and educate sales staff on what the AEPA cooperative contract is including pricing, who can order from the contract (by state), terms/conditions of the contract and the respective ordering procedures for each state. It is expected that Vendor Partners will lead with AEPA contracts.
3. Develop a marketing plan to support the AEPA contract in collaboration with respective AEPA Member Agencies. Plan should include, but not be limited to, a website presence, electronic mailings, sales flyers, brochures, mailings, catalogs, etc.
4. Create an AEPA-specific sell sheet with a space to add a Member Agency logo and contact information for use by the Member Agencies and the Vendor Partner's local sales representatives to market within each state.
5. On a quarterly basis, complete the sales and administrative fee report (see PDF template) and submit to each Member Agency along with the respective administrative fees to be paid. If there are no sales, a \$0 report is required.
6. Report sales and administrative fees by participating state if requested by AEPA.
7. Have ongoing communication with the Category Committee Chairperson, AEPA Member Agencies and the Member Agencies Participating Entities.
8. Annually attend two (2) AEPA meetings: Annual meeting which is typically in April and the Winter Meeting which is typically the end of November or early December and has historically been held in conjunction with the Association of Educational Service Agencies (AESAs) annual conference. At the Annual meeting, Vendor Partners participate in a round table meeting with each of the AEPA Member Agencies. Vendor Partners that have paid the registration fees can participate in the meetings.
9. Trade show support: Strongly encourage participation in national and local conference trade shows to promote the AEPA contracts such as, but not limited to, the Association of School Business Officials (ASBO), the National Institute of Governmental Purchasing (NIGP), and the National Association of Educational Procurement (NAEP).
10. Increasing sales over the term of the contract with all participating AEPA Member Agencies.

IV. Responsibilities of AEPA Member Agencies

A. In support of the Vendor Partner and respective contract, each AEPA Member Agency should provide the following support:

1. Designate a staff member(s) that will serve as a point person for the AEPA program within that state.
2. Provide a staff member to work collaboratively with the Vendor Partner to determine the best marketing plan for the respective Member Agency state. Marketing efforts may include but not be limited to the education and use of sales force, a website presence, electronic mailings, brochures, mailings, etc.
3. Develop marketing materials for the Member Agency to use that would include representation of the awarded contracts. Materials may include, but not be limited to, a website presence, electronic mailings, sales flyers, brochures, mailings, catalogs, etc. as determined by the respective Member Agency and what works best within their state.
4. Assist the Vendor Partner to jointly market the contract to potential Participating Entities within the state.
5. Work with the Vendor Partner to identify eligible Participating Entities within the state possibly including providing a list of potential customers.
6. Work with the Vendor Partner to identify and help manage costs associated with fulfilling this contract.

7. Attendance at the two (2) AEPA meetings which provides for opportunity to interact with Vendor Partners.

V. General Terms and Conditions for All Agencies

For the purposes of this INVITATION FOR BID, the following terms shall be defined as indicated below, and constitute the general terms and conditions for all AEPA Member Agencies:

Administrative Fee: The percentage of sales that each Vendor Partner pays the Member Agency for sales in their respective state or states that they extend the AEPA pricing to. Administrative Fees shall be paid to each Member Agency on a quarterly basis. See the Summary of State General Overview for the administrative fees by Member Agency (state).

Advertising: Vendor Partner shall not advertise or publish information concerning this contract prior to the award being announced by the AEPA Member Agencies. Once the award is made, the Vendor Partner may advertise to the individual Participating Entities that products/services are available. Vendor Partner shall submit ad copy to the AEPA Member Agency for review and approval prior to issuing the advertisement.

AEPA Bi-Annual Meetings: AEPA holds two general meetings each year: one in the Spring (usually in the months of April or May) and the other in the Fall (currently the week after Thanksgiving). AEPA requires that all successful contract holders attend both meetings and participate in the vendor round tables at the Spring meeting. AEPA request that all vendor partners register in advance and stay at the AEPA official hotel if rooms are available. All registrations for the meetings are required by the official registration due date as announced by AEPA.

AEPA Member Agency: Refers to the entities identified in the table in Part I of this document. Member Agencies participating in a particular bid category are listed on the table presented in Part B - Specifications, Item 3: Anticipated Member Agency Participation. "Direct or Indirect Participation" may include their involvement through the formulation of any part of a procurement activity; the influencing of the content of any term, condition and/or specification; the evaluation, investigation, auditing and/or the rendering, of advice, recommendation, decision, approval, disapproval and the award and implementation of procurement contract. Not every listed entity may elect to participate in this bid once the responses are reviewed and approved.

Affirmative Action: An Affirmative Action Plan, Certificate of Affirmative Action, or other documentation regarding Affirmative Action may be required by AEPA Member Agencies. Vendors must comply with requirements and/or requests for information regarding Affirmative Action by Member Agencies.

Amendment of Bid: A bid may be amended up to the time of opening by submitting a sealed letter to the place where the bids are received as indicated on the front of this solicitation.

Applicable Law: The laws of the state of the respective AEPA Member Agency shall govern any resulting contract of this bid. Suits pertaining to this contract may be brought only in courts in the County and State as prescribed by the AEPA Member Agency. Both parties agree that the Uniform Commercial Code, as adopted by the State of the AEPA Member Agency, shall fully apply. The Vendor Partner shall comply with any and all laws, whether local, state, federal or otherwise, applicable to any aspect of the work to be performed in relation to the resulting contract. It shall be the Vendor Partner's responsibility to identify, make themselves aware of and determine the applicability and requirements of any such laws and to abide by them.

Approval and Awarding of Contract: AEPA and its AEPA Member Agencies reserve the right to approve and award a contract to one Bidder, to make multiple approvals and awards, to reject any or all bids in whole or in part, to waive any minor formalities or irregularities in any bids, and to accept

bids, which in its discretion and according to law may be in the best interest of the AEPA Member Agencies and their Participating Entities. A response to this solicitation is an offer to contract with the AEPA Member Agencies based upon the terms, conditions, and scope of work and specifications contained in this invitation. A solicitation does not become a contract unless and until it is accepted, recommended and approved by AEPA and awarded by the individual AEPA Member Agency. A contract is formed when an AEPA Member Agency administrator and, if required, an AEPA Member Agency Board approves and signs the Acceptance of Bid and Contract Award Form (see Form E) document, eliminating the need for a formal signing of a separate contract.

Assignment: No right or interest in this contract shall be assigned or transferred by the Vendor Partner without prior written permission by AEPA and its AEPA Member Agencies, and no delegation of any duty of the Vendor Partner shall be made without prior written permission by the AEPA Member Agency. AEPA and its AEPA Member Agencies shall not unreasonably withhold approval and shall notify the Vendor Partner within fifteen (15) days of receipt of written notice by the Vendor Partner.

Audit Rights: In accordance with applicable law of the State of the AEPA Member Agency, the Vendor Partner's books and pertinent records related to this contract may be audited at a reasonable time and place.

Authority: This solicitation, as well as any resulting contract/agreement, is issued under the general authority of the State laws of the AEPA Member Agency and those identified within the AEPA Member Agencies' Specific Terms and Conditions, Part C, (see also Procurement Code). Internal or external Cooperative Purchasing Agreements between the AEPA Member Agency and Participating Entities may exist.

Bid Opening: Bids shall be opened in the manner designated in this document.

Bidder/Vendor Partner Definitions:

Bidder, Offeror and Vendor Partner are interchangeable and are used to identify the person(s) or firm(s) submitting a response to an Invitation for Bid.

1. Prospective Bidder: has notified AEPA of a desire to bid by registering on the AEPA website. "Bidder" has submitted a bid to AEPA in response to an Invitation for Bid (IFB).
2. Recommended Bidder: has been approved by AEPA for its AEPA Member Agencies for contract consideration.
3. Vendor Partner: has entered into a contract with a participating AEPA Member Agency or subsequently a Participating Entity.

Bidder Acceptance Period: In order to allow AEPA Member Agencies the opportunity to evaluate the bids, AEPA requires that a bid in response to this solicitation be valid and irrevocable for one hundred twenty-days (120) after opening time and date.

Bonding (required for construction projects): The Vendor Partner agrees to provide all performance and payment bonds executed by a surety company authorized to do business in the individual AEPA Member's state and said surety to be approved in federal circular 570 as published by the United States treasury department, the state or the local governing authority, in an amount equal to one hundred percent of the price specified in the contract; when required by an AEPA Member Agency or Participating Entity at the time a contract is executed. If the Vendor Partner fails to deliver any required performance or payment bonds, the AEPA Member Agency or Participating Entity shall not execute the contract with the Vendor Partner and the appropriate AEPA Category Committee shall be notified of such failure and shall take the appropriate action.

Brand Names: The use of the name of a manufacturer, brand, make or catalog number does not restrict the Bidder. Brand names and model numbers are used to indicate the character, quality and/or performance equivalence of the commodity on which bids are submitted. Bidders may submit alternates. However, the AEPA reserves the right to decide whether alternatives to the identified manufacturer and brand are in fact equal to the product, equipment and/or service described in the invitation. AEPA's decision shall be final.

Buyer: Identifies the AEPA Member Agencies and their Participating Entities that acquire and purchase commodities, supplies, materials, equipment and services under AEPA Member Agencies' awarded contracts.

Captions, Headings and Illustrations: The captions, illustrations, headings and subheadings in this solicitation are for explanation only and in no way define, limit or describe the scope or intent of the request.

Certification: By signature in the bid section of the Contract Award page, the Bidder certifies: the submission of the bid did not involve collusion or other anti-competitive practices; the Bidder shall not discriminate against any employee, or applicant for employment in violation of Federal and State Laws (see Federal Executive Order 11246); the Bidder has not given, offered to give, nor intends to give at any time hereafter any economic opportunity, future employment, gift, loan, gratuity, special discount, trip, favor or service to a public servant in connection with the submitted bid; and the Bidder agrees to promote and offer to AEPA Member Agencies and Participating Entities only those materials and/or services as stated in and allowed under resultant contract(s) awarded.

Christian Doctrine: Any federal, state and local governing authority's/jurisdiction's statutes, codes, rules and regulations referenced and/or govern the products, services and activities relating to and are part of this solicitation, whether or not physically noted or included, shall be complied with and adhered to as required. It is sole responsibility of the Bidder to perform and complete any necessary research and investigation required to make themselves aware of and comply with this item.

Clarification: As used in this solicitation, clarification means communication with a Bidder for the sole purpose of eliminating minor irregularities, informalities or apparent clerical mistakes in the bid. It is achieved by explanation or substantiation, either in response to an inquiry by the AEPA Member Agency or as initiated by the Bidder. Clarification does not give the Bidder an opportunity to revise or modify its bid.

Commercially Available Catalog: A published paper catalog or an online website that is widely distributed or accessible. It is made available to the general public or schools and contains a verifiable price, along with product descriptions, SKU numbers, and photographs. A commercially available catalog is distinct from a custom catalog or website, whose prices and offerings are tailored to niche audiences.

Competitive Range: AEPA and its AEPA Member Agencies reserve the right to establish a competitive range of acceptable responses as part of the evaluation process as defined herein. Responses below the competitive range will be determined to be unacceptable and will not receive further consideration.

Contract Documents: AEPA Member Agency will review proposed contract documents. Vendor Partner's contract document shall not become part of AEPA Member Agency's contract with Vendor Partner unless and until an authorized representative of an AEPA Member Agency reviews and accepts it.

Construction: Each AEPA Member Agency within their state statutes defines what constitutes construction, identifies the policies, rules, regulations and codes that govern construction projects.

AEPA has defined construction as building, altering, repairing, installing or demolishing in the ordinary course of business any road, highway, bridge, parking area or related project; building, stadium or other structure; airport, subway or similar facility; park, trail, athletic field, golf course or similar facility; dam, reservoir, canal, ditch or similar facility; sewage or water treatment facility, power generating plant, pump station, natural gas compressing station or similar facility; sewage, water, gas or other pipeline; transmission line; radio, television or other tower; water, oil or other storage tank; shaft, tunnel or other mining appurtenance; electrical wiring, plumbing or plumbing fixture, gas piping, gas appliances or water conditioners; air conditioning conduit, heating or other similar mechanical work; or similar work, structures or installations. Construction shall also include: leveling or clearing land; excavating earth; drilling wells of any type, including seismographic shot holes or core drilling; and similar work, structures or installations.

Cooperative Procurement: Some individual state procurement codes may contain cooperative purchasing statutes that state any state agency or local public body may either participate in, sponsor or administer a cooperative procurement agreement for the procurement of any services, construction or items of tangible personal property with any other state agency, local public body or external procurement unit in accordance with an agreement entered into and approved by the governing authority of each of the state agencies, local public bodies or external procurement units involved. The cooperative procurement agreement shall clearly specify the purpose of the agreement and the method by which the purpose will be accomplished. Any power exercised under a cooperative procurement agreement entered into pursuant to each state's procurement code shall be limited to the central purchasing authority common to the contracting parties, even though one or more of the contracting parties may be located in different states.

Cooperative Purchasing Contracts: The Bidder agrees that all the prices, terms, warranties and benefits granted by the Bidder to AEPA Member Agencies or Participating Entities through this contract **will be equal to or better than** those offered to any individual entities or cooperatives that have equal or lesser volume. If the Bidder shall, during the term of this Contract, enter into arrangements with any customer or cooperative providing greater benefits or terms that are more favorable, the Bidder shall notify the AEPA category committee chairman and offer said prices, terms, warranties and benefits to all AEPA Member Agencies. The following shall be noted:

1. AEPA and its AEPA Member Agencies reserve the right to accept or reject the Bidder's response if it is determined it does not comply with the above based on their knowledge, investigation, review and findings of Bidders' submitted prices.
2. In the event the Vendor Partner offers lower prices to another customer or cooperative, AEPA and its AEPA Member Agencies shall notify the Vendor Partner of the deviation and request written justification. Based on AEPA and its AEPA Member Agencies' investigation, review and findings, AEPA reserves the right to take the following actions: to request the Vendor Partner to immediately adjust its AEPA's offered prices to match the lower prices offered, to work with the Vendor Partner to mediate and resolve the situation; or to notify the Vendor Partner that it intends to suspend and/or terminate their contract.

Cost of Bid Preparation: Neither AEPA nor any AEPA Member Agency shall reimburse the cost of developing, presenting or providing any response to this solicitation.

Credit Hold: The Bidder must agree not to place the AEPA Member Agency and/or its Participating Entity on "credit hold" without 10-days advanced notice in writing, either by letter, facsimile or email to the AEPA Member Agency and the Participating Entity. The AEPA Member Agencies believe it is better for the Vendor Partner if the AEPA Member Agency places the slow-paying Agency Member on "credit hold;" if a Vendor Partner places the Participating Entity on credit hold, agencies that pay promptly are penalized. If, on the other hand, the Member Agency places the offending Participating Entity on "credit hold", payment is more likely to result and only the offender is disciplined.

Delivery Terms, Conditions and Requirements

1. **Delivery:** is to be made within the specified time identified in Part B Specifications for each bid category, unless otherwise stipulated in writing and accepted by all parties (Buyer placing order and Vendor Partner). The Vendor Partner agrees to notify Buyer if an order cannot be processed within the specified period and/or the agreed upon timelines.
2. **The title and risk of loss of material or service:** shall not pass to the Buyer purchasing the material or services until it actually receives the material or service at the point of delivery (FOB Destination) and they have been accepted, unless otherwise provided within this document or individual project's contract.
3. **Ownership of products and services:** happens only after receipt and acceptance of delivery by the Buyer. The Buyer will be the determining judge of whether materials and services delivered under the purchase order/contract satisfy the specifications and requirements as identified in the contract/order.
4. **Fungible Goods:** Title to an undivided share or quantity of an identified mass of fungible goods will not pass to a Buyer until a separation of the purchased share has been made, delivered and received.
5. **Shipping Terms:** (See Part B Specifications for specific instructions on shipping and handling costs for the individual category you are bidding on.) Vendor Partner shall retain title and control of all goods until they are delivered and received. All risk of transportation and all related charges shall be the responsibility of the Vendor Partner, unless other arrangements have been made between the vendor partner and the AEPA Member Agency. Shipping shall be F.O.B. destination. The Vendor Partner shall file all claims for visible or concealed damage. AEPA Member Agency, or the receiving Buyer, will notify the Vendor Partner and/or Freight Company promptly of any damaged goods and shall assist the freight company/Vendor Partner in arranging for inspection. No F.O.B. vessel, car or other vehicle terms will be accepted.
 - a. **Shipping Costs:** Products may be shipped without separate shipping costs. If shipping is allowed as a separate line item per Part B Specifications and charged, the actual cost of delivery may be added to an invoice. No COD orders will be accepted unless specifically requested by the AEPA Member Agency.
 - b. **Shipment under Reservation:** Vendor Partner is not authorized to ship materials under reservation and no tender of a bill of lading will operate as a tender of the materials.
 - c. **Shipping Errors:** Vendor Partner agrees that shipping errors will be at the expense of the Vendor Partner. For example, if a Vendor Partner ships a product that was not ordered, it is the responsibility of the Vendor Partner to pay for return mail or shipment.
6. **Stored Materials (Vendor managed inventory):** Upon prior written agreement between Vendor Partner and Buyer, payment may be made for materials not incorporated in the work but delivered and suitably stored at the site or some other location, for installation at a later date. An inventory of the stored materials must be provided to Buyer prior to payment. Such materials must be stored and protected in a secure location, and be insured for their full value by Vendor Partner against loss and damage. Vendor Partner agrees to provide proof of coverage and/or addition of Buyer as an additional insured upon Buyer's request. Additionally, if stored offsite, the materials must also be clearly identified as property of Buyer and be separated from other materials. Buyer must be allowed reasonable opportunity to inspect and take inventory of stored materials, on or offsite, as necessary. Until final acceptance by Buyer, it shall be Vendor Partner's responsibility to protect all materials and equipment. Vendor Partner warrants and guarantees that title for all work, materials and equipment shall pass to Buyer upon final acceptance. Payment for stored materials shall not constitute final acceptance of such materials.
7. **Improper delivery:** Unless contrary to other parts of this solicitation, if the goods, services or tender of delivery fail in any respect to conform and adhere to the terms, conditions, specifications of the resulting contract based on this solicitation and/or the individual Buyer's contract/order. The Buyer may reject the whole, accept the whole, or accept any commercial unit or units and reject the rest.
8. **Defective Goods:** Vendor Partner agrees to pay for return shipment on goods that arrive in a defective or inoperable condition. Vendor Partner must agree to arrange for return shipment of damaged goods.

9. **Liquidated Damages:** The Buyer may suffer financial loss if the project is not substantially complete or products or services are not delivered on the established date. The Vendor Partner (if applicable Surety) shall be liable for and shall pay to the Buyer, not as a penalty, the sums that may be hereinafter agreed upon as liquidated damages per calendar day of delay until the work and/or delivery is determined by Buyer to be complete and/or delivered. Liquidated damages will be determined on a project-by-project basis.
10. **No Replacement of Defective Tender:** Every tender of materials must fully comply with all provisions of this contract. If tender is made which does not fully conform, this shall constitute a breach and Vendor Partner shall not have the right to substitute a conforming tender without written consent of all parties involved.
11. **Default in One Installment to Constitute Total Breach:** Vendor Partner shall deliver conforming materials in each installment or lot of this contract and may not substitute nonconforming materials. The AEPA Member Agency reserves the right to declare a breach of contract if the Vendor Partner delivers nonconforming materials or services to any Buyer under this contract.
12. **Restocking Fees:** A restocking fee may only be charged on products ordered and that have been delivered to the Buyer's site in accordance with the order/contract. Restocking fees in excess of 15% will not be allowed. Restocking fees may be waived, at the option of the Vendor Partner. The Vendor Partner must identify, specify and justify any exceptions or deviations taken.

Deviations or Exceptions to Requirements: Deviations or exceptions stipulated in a Bidder's proposal may result in rendering of the response non-responsive. AEPA and its AEPA Member Agencies reserve the right to determine whether the deviation or exception does or does not serve the interest of or is not advantageous or acceptable to AEPA, its AEPA Member Agencies or Participating Entities.

Disbarment and Suspension: By signature accepting Terms and Conditions, it is certified on behalf of the company and their key employees that neither the company nor its key employees have been proposed for debarment, debarred, or suspended by any State or Federal Agency within the last five (5) years.

EDGAR Compliance: Bidders are required to complete Education Department General Administrative Regulations (EDGAR) compliance certification. EDGAR regulations govern all federal grants awarded by the U. S. Department of Education on or after December 26, 2014.

Eligible Entities: The individual AEPA Member Agency's state procurement code and statutes provides for cooperative procurement and identifies those types of agencies, entities and organizations that are allowed to participate in and take advantage of cooperative procurement contracts solicited and approved by AEPA and awarded by AEPA Member Agencies. Therefore, depending on the individual state procurement codes and statutes federal agencies, state agencies, local public bodies and Non-Profit/Non-Public entities may be allowed to participate in and utilize AEPA solicited, approved and AEPA Member Agency awarded contracts.

Estimated Quantities: In Part B: Bid Specifications of this solicitation AEPA and AEPA Member Agencies have indicated their anticipated volume for the products and services being solicited in this solicitation. It is anticipated that a considerable amount of activity will result from this solicitation; however, there is no guarantee of future order quantities due to the fact that this is an indefinite quantity contract. Usage depends on the actual needs of the AEPA Member Agencies, their Participating Entities and the marketing by the Vendor Partner.

Experience, Proven Track Record and Past Performance Information: has been determined by AEPA and its AEPA Member Agencies to be a major factor in consideration if a Bidder possesses the ability, capacity and resources to acquire, manufacture, deliver, construct, install, services and support all of the procurement functions and activities involved in a national contract of this nature. AEPA and its AEPA Member Agencies reserve the right to accept or reject an offer, if in its judgment, the Bidder

failed to demonstrate the following: a proven track record in the products and services offered (qualifications, knowledge and background); is willing and able to deliver the proposed products and/or services to ninety (90%) percent of those participating AEPA Member Agencies identified in Part B (unless otherwise noted in Part B.): Specifications; and has provided relevant information regarding its actions under previously awarded contracts to schools, local, state, or federal agencies. It includes the Bidder's record of conforming to specifications and to standards of good workmanship; the Bidder's record of containing and forecasting costs on any previously performed cost reimbursable contract schedules, including the administrative aspects of performance; the Bidder's history for reasonable and cooperative behavior and commitment to customer satisfaction; and generally, the Bidder's businesslike concern for the interests of the customer.

External Procurement Unit: means any procurement organization not located in a current AEPA Member Agency state which, if located in the state, would qualify as a federal or state agency or a local public body. Various state procurement codes allow external procurement units to offer their contracts and for agencies within those states to utilize those contracts to acquire goods and services.

Federal Agency [25] USC 3001 (4): Is defined as any department, agency, or instrumentality of the United States, any executive department, military department, government corporation, government-controlled corporation, or other establishment in the executive branch of government, including the Executive Office of the President or any independent regulatory agency established through legislative and/or administrative action.

Federal Requirements: Vendor Partner agrees, when working on any federally assisted projects with more than \$2,000 in labor costs, to comply with the Contract Work Hours and Safety Standards Act (40 U.S.C. 328 et seq.) and all applicable sections of the act and the Department of Labor's supplemental regulations (29 CFR parts 5 and 1926), the Civil Rights Act of 1964 as amended, the Davis-Bacon Act (Section 29, CFR Part 5), the Copeland "Anti-Kickback" Act (18 U.S.C. 874) as supplemented in the Department of Labor regulation (29 CFR part 3), and the Equal Opportunity Employment requirements of Executive Order 11246 as amended by Executive Order 11375 (Labor regulations (41 CFR Part 60)). In such projects, the Vendor Partner agrees to post wage rates at the work site and submit a copy of their payroll to the AEPA Member Agency for their files. In addition, to comply with the Copeland Act, the Vendor Partner must submit weekly payroll records to the AEPA Member Agency. The Vendor Partner must keep records for three (3) years and allow the federal grantor agency access to these records, upon demand. All federally assisted contracts to an AEPA Member Agency that exceed \$10,000 may be terminated by the federal grantee for noncompliance by the Vendor Partner. In projects that are not federally funded, Bidder must agree to meet any federal, state or local requirements, as necessary. In addition, if compliance with the federal regulations increases the contract costs beyond the agreed on costs in this solicitation, the additional costs may only apply to the portion of the work paid by the federal grantee. On all other projects, the prices must agree with this contract. Vendor Partner shall comply with all applicable standards, orders, or requirements issued under Section 306 of the Clean Air Act (42 U.S.C.) 187 [h], and the Federal Water Pollution Control Act as amended (33 U.S.C. 1251 et. Seq.); and, Executive Order 11738 and Environmental Protection Agency (EPA) regulations (40 CFR Part 15), which prohibit the use under non-exempt federal contracts, grants, or loans of facilities included in the EPA list of violated facilities

Force Majeure: Except for payments of sums due, neither party shall be liable to the other, nor be deemed in default under this contract, if, and to the extent, that such party's performance of this contract is prevented by reason of force majeure. The term "force majeure" means an occurrence that is beyond the control of the party affected and occurs without its fault or negligence, including, but not limited to the following: acts of God; acts of the public enemy; war; riots; strikes; mobilization; labor disputes; civil disorders; fire; flood; blizzards; earthquakes; tornadoes or violent winds; hail storms; lockouts; injunctions-intervention-acts, or failures or refusals to act by government authority; and other similar occurrences beyond the control of the party declaring force majeure, which such party is unable to prevent by exercising reasonable diligence. The force majeure shall be deemed to commence

when the party declaring it notifies the other party of the existence of the force majeure, and shall be deemed to continue as long as the results or effects of the force majeure prevent the party from resuming performance in accordance with the contract. Force majeure shall not include late deliveries of equipment or materials caused by congestion at a manufacturer's plant or elsewhere, an oversold condition of the market, inefficiencies, or similar occurrences. If either party is delayed at any time by force majeure, the delayed party shall notify the other party in writing of such delay within forty-eight (48) hours.

Form of Contract: The form of contract for this solicitation shall be the Invitation for Bid, the awarded Bidder response and properly issued purchase orders and/or contracts in accordance with this Invitation for Bid. If a firm submitting a bid requires AEPA Member Agency and/or Participating Entities to sign an additional contract, a copy of the proposed contract must be included with the bid.

Gratuities: AEPA Member Agency may, by written notice, cancel this contract if it is found that gratuities, in the form of entertainment, gifts or otherwise, were offered or given by the Vendor Partner or any agent or representative of the Vendor Partner, to any employee of the AEPA Member Agency with a view toward securing a contract or with respect to the performance of this contract. However, paying the expenses of normal business meals, which are generally made available to all eligible school and government employees, shall not be prohibited by this paragraph. Samples of software, equipment, or hardware provided to the AEPA Member Agency for demonstration, evaluation, or loan purposes are not considered gratuities.

Indemnification: Vendor Partner will indemnify, defend and save harmless AEPA, its Members, Participating Entities, its employees from any and all claims, demands, suits, proceedings, loss, cost and damages of every kind and description, including any attorney's fees and/or litigation expenses, which might be brought or made against or incurred by, AEPA, its Members, Participating Entities, its employees on account of loss or damage to any property or for injuries to or death of any person, caused by, arising out of, or contributed to, in whole or in part, by reasons of any act, omission, professional error, fault, mistake, or negligence of Vendor Partner, its employees, agents, representatives, or Subcontractors, their employees, agents, or representatives in connection with or incident to the performance of this agreement, or arising out of worker's compensation claims, unemployment compensation claims, or unemployment disability compensation claims of employees of Vendor Partner, and/or its Subcontractors or claims under similar such laws or obligations. Vendor Partner's obligation under this section will not extend to any liability caused by the sole negligence of AEPA, its Members, participating Entities, its employees. The liability of AEPA, its Members, Participating Entities or its employees will be subject in all cases to the immunities and limitations of Nevada or the AEPA Member Agency's state laws. Installation: Equipment and items of construction shall be installed in accordance with the manufacturer's instructions, specifications, in accordance with any federal, state, local rules, regulations, codes and the schedule determined by the AEPA Member Agency and/or Participating Entity.

Insurance: Prior to executing a contract with the AEPA Member Agency or a Participating Entity under this solicitation, if required, the Vendor Partner shall procure, maintain and provide certification from insurer(s) for minimal coverage during the life of any resulting contract/agreement, to include but not limited to comprehensive public and/or commercial liability, errors and omissions, workman's compensation, unemployment and other insurance coverage required by and applicable to each AEPA Member Agency state's statutes and federal laws in which proposed products and services will be offered and provided. Evidence of the required insurance for each of those AEPA Member Agencies' state, who indicated an interest to participate in this solicitation, identified in Part B: Specifications by providing written evidence and/or documentation from your insurer(s) indicating your firm has in place the type and amount of coverage required by each of the states. The Bidder has the sole responsibility to conduct and perform the necessary research to make themselves aware of and to understand each states requirements.

1. **Certificate of Insurance:** The Vendor Partner shall provide, as required, a certificate of insurance for commercial liability insurance naming the AEPA Member Agency and or its Participating Entity as the certificate holder (co-insurer). All insurance policies are to be executed by an insurance company authorized to do business in those AEPA Member Agencies' states participating in this solicitation.
2. **Subcontractor's Insurance:** Prior to commencing any work, any Subcontractor shall procure and maintain, at its own expense until final acceptance of the work, insurance coverage in a form and from insurers acceptable to the prime Vendor Partner. All Subcontractors shall hold the appropriate type and amount of insurance coverage required by the AEPA Member Agency state in which the work is being done and will provide insurance, which waives all subrogation rights against the prime Vendor Partner, AEPA Member Agency and its Participating Entities.

Invalid Term or Condition: If any term or condition of this solicitation and any resulting contract shall be held invalid or unenforceable, the remainder of this solicitation and any resulting contract shall not be affected and shall be valid and enforceable.

Late Bids: Late bids will not be accepted. All bids must be submitted online via Public Purchase by the due date and time of this IFB.

Leases and Rentals: Vendor Partner may allow AEPA Member Agency or Participating Entity to rent, lease or lease purchase. Buyer must receive a copy of the executed leasing documents prior to processing a purchase order. Vendor Partner agrees that leases will be in compliance with the Uniform Commercial Code and the Buyer's individual state laws. All terms of leasing must be included in the bid, with interest rates described as related to a published government standard. Vendor Partner must indicate in their response to this solicitation and in any leasing/rental agreement, all costs (must be itemized) associated with early termination and/or the returning of leased or rented equipment that are the responsibility of the Buyer. No sale of a contract to a third party will be made without informing the Buyer of the transfer. If Vendor Partner sells a lease contract to a third party, the cost of return of the product must not be greater than the cost of return to the original Vendor Partner.

Legal Remedies: All claims and controversies shall be subject to the Procurement Code of the state in which the AEPA Member Agency or Participating Entity resides.

Licenses and Registration: Each state and local jurisdictions in which a transaction may occur may require various types of licenses and/or registrations (business, construction Vendor Partner, etc). Likewise, there are various policies, procedures, rules, regulations, codes and laws that govern such licensing/registration within federal, state and local jurisdictions, therefore, it is the Bidder's/Vendor Partner's responsibility to be aware of, obtain and maintain in current status all federal, state and local licenses, registrations and bonds required for the performance and delivery of any and all products and services offered in its response to this solicitation. It is also the responsibility of the Bidder/Vendor Partner to ensure that any Subcontractors performing under this bid hold and maintain the appropriate licenses/registrations. The Bidder will submit copies of licenses, registration and/or other documentation to substantiate they hold the appropriate licenses/registration required by individual jurisdictions covered by this solicitation.

Liens: All materials and services shall be free of all liens.

Local Public Body: A political subdivision of the state and the agencies, instrumentalities and institutions thereof. Such agencies may include but are not limited to two-year and four-year post-secondary educational institutions, pre-k-12 institutions, counties, cities and municipalities, except as exempted pursuant to the Procurement Code within each state. Entities within these groups may include but are not limited to political subdivisions, administrative units, councils, commissions, boards and organizations that either by federal, state or local legislative or administrative action or

appointment and have been established or given the responsibility and authority to act, conduct and perform various activities on behalf of the federal or state agency or local public body.

Manufacturer's Representative: Dealers, distributors and installers of specialized facility technology, electrical, mechanical systems and equipment, who, if permitted by the Scope of Work, submit an offer as a manufacturer's representative, must be able to provide documented evidence from and/or between it and the manufacturer certifying that the Bidder is a bona fide manufacturer's agent for the specific products/services proposed, the Bidder is authorized to submit an offer on such products/services, and a guarantee that, should the Bidder fail to satisfactorily fulfill any obligations established as a result of the award of contract, the manufacturer will either assume and discharge such obligations covered by warranties or provide for their competent assumption by one or more bona fide representatives for the term of the contract/warranty period. Bidders of software, mechanical devices, electrical products/systems and other commodities that make up systems/networks must be able to provide the same information from a manufacturer.

Modification by Buyer: Vendor Partner shall have no obligation with respect to any patent and copyright infringement claim based upon Buyer's modification of the equipment and/or software, or its operation or use with apparatus, data or programs not furnished by Vendor Partner. However, one Buyer's action will not preclude Vendor Partner's obligation to others not having modified their equipment or software.

Money: All transactions are payable in U.S. currency only. **Multiple Approvals and Awards:** Throughout the United States, AEPA Member Agencies have a large number of Participating Entities who take advantage of and utilize awarded contracts. In order to assure that any issued contract will allow these entities to fulfill current and future needs and requirements, AEPA and its AEPA Member Agencies reserve the right at its discretion to approve and/or award one contract, multiple contracts or no contracts. The actual use of any contract will be at the sole discretion of the AEPA Member Agency or the Participating Entity.

Nonexclusive Contract: Any contract resulting from this solicitation shall be approved and awarded with the understanding and agreement that it is for the sole convenience of the AEPA, its AEPA Member Agencies, their Participating Entities and they reserve the right to obtain like goods and services from another source.

Nonprofit, Non-Public Educational Institutions and other Nonprofit Organizations (Section 501(c)(3) of the Internal Revenue Code, Federal Tax Code): is defined as charitable, religious, educational, public service, support and scientific organizations, entities, corporations that qualify as exempt organizations under Section 501(c)(3) of the Internal Revenue Code, or corresponding section of the Federal Tax Code.

Notice: Notices under this solicitation/contract will be in writing and will, for all purposes, be deemed to have been fully given when sent by registered or certified mail, return receipt requested, postage prepaid, email with appropriate verification, properly addressed to the respective parties as specified herein or at such other address as may be specified by either party from time to time.

Novation: If the original Vendor Partner sells or transfers all assets or the entire portion of the assets used to perform this contract, a successor in interest must guarantee to perform all obligations under this contract. AEPA and its AEPA Member Agencies reserves the right to recommend approval, acceptance or rejection of the new party. A simple change of name agreement will not change the contractual obligations of the Vendor Partner.

Ordering Procedures: AEPA has established a standard and special ordering process as defined below. Additionally, some AEPA Member Agencies also prefer or utilize electronic ordering as the

method for the transactions. For details on the ordering processes utilized for each AEPA Member Agency, please reference the Summary of State General Overview.

1. **Standard Ordering Process:** Buyer will select items for purchase from provided published catalog/price list or Vendor Partner will issue a quote upon request; the vendor will also send a copy of their quote to the state AEPA Member Agency for all construction related bids. Buyer will prepare and issue a purchase order to the Vendor Partner based on the product catalog, pricelist or Vendor Partner's quote. Vendor Partner will deliver and invoice the Buyer; Buyer will acknowledge delivery and acceptance by issuing the Vendor Partner payment. Vendor Partner, based on the agreed to process, will report and submit payment for the AEPA Member Agency's administrative fee to the AEPA Member Agency (quarterly). Vendor Partner shall provide the transaction and volume reporting in the AEPA report format.
2. **Special Ordering Process:**
 - a. Buyer will select items for purchase from provided published catalog/price list or Vendor Partner will issue a quote upon request;
 - b. Buyer will prepare and issue a purchase order to the AEPA Member Agency based on the product catalog, pricelist or Vendor Partner's quote;
 - c. Vendor Partner will deliver the goods and/or service to the Buyer and will invoice the AEPA Member Agency;
 - d. AEPA Member will invoice the Buyer and add their administrative fee to the invoice price;
 - e. AEPA Member will pay Vendor Partner for the goods and/or service once the Buyer has confirmed acceptance.
 - f. Vendor Partner shall provide the transaction and volume reporting as stipulated on a quarterly basis in the AEPA report format.
3. **Electronic Ordering (Optional by AEPA Member Agency):**
 - a. When a Vendor Partner based online ordering system is available, the following functionality is preferred:
 - b. Electronic ordering systems shall be secure and password protected. Entering the system with the designated password shall automatically send the user to AEPA contract pricing.
 - c. When the Buyer requires purchase orders, electronic ordering system shall require entry of a purchase order number, credit card or purchasing card prior to accepting an order.
 - d. Electronic ordering systems shall block excluded items not covered by the AEPA contract from any order.
 - e. Electronic ordering systems shall automatically assign correct contract prices to applicable orders.
 - f. Electronic ordering systems that list catalog price and AEPA discounted price.
 - g. Electronic ordering systems shall track orders and purchases covered by the AEPA contract for reporting and audit purposes. Vendor Partner shall provide the transaction and volume reporting in the AEPA format.
 - h. Electronic ordering systems' pricing shall include the AEPA Member Agencies administrative fee required by the AEPA Member Agencies.
 - i. Electronic ordering systems that allow AEPA Member Agencies to print an archived (historical) copy of a Buyer's order.

Order of Precedence: In the event a conflict occurs the following order of precedence shall prevail:

1. Member Agency Specific terms and conditions
2. Specifications and scope of work
3. General terms and conditions
4. Attachments and exhibits
5. Documents referenced or included in the solicitation

Overcharges by Antitrust Violations: Member Agency maintains that, in actual practice, overcharges resulting from antitrust violations are borne by the Buyer. Therefore, to the extent permitted by law, the Vendor Partner hereby assigns to the Member Agency any and all claims for such overcharges as to the goods or services used to fulfill the contract.

Parole Evidence: This contract represents the final written expression of agreement. All agreements are contained herein and no other agreements or representations that materially alter it are acceptable.

Participating Entity: Those Public and Private School Districts, Educational Service Agencies, Intermediate School Districts, Higher Education Institutions, Federal Agencies, State Agencies, Local Public Bodies and Nonprofit Non-Public Corporations, Organizations, other entities contracted to conduct business on behalf of a participating entity provided they are required to follow member state and local procurement regulations, etc. that have authorizations to utilize the AEPA Member Agencies' Awarded Contracts.

Patent and Copyright Indemnification: To the extent permitted by law, Vendor Partner shall indemnify and hold harmless Member Agency and its Participating Entities against any liability, including costs and expenses, for infringement of any patent, trademark or copyright arising out of contract performance or use by Member Agency and its Participating Entities of materials furnished or work performed under this contract. Member Agency and its Participating Entities shall reasonably notify Vendor Partner of any claim for which it may be liable under this paragraph.

Piggy Back Contracts: In the event a new Member Agency joins AEPA, the Member Agency may elect to award any and all existing contracts if permissible by their State laws.

Prevailing Wage: Where applicable, the Vendor Partner must comply with prevailing wage legislation in effect in the jurisdiction of the awarding AEPA Member Agency.

Pricing: AEPA has identified and stipulated the type of bid and the pricing methodologies that are to be utilized to price and submit bid prices. The Vendor Partner agrees that the cost for any item bid or offered on this contract will be uniform for all states, and that any differences in pricing are due to state specific installation and labor costs, AEPA Member Agency's Administrative Fee, or other approved reasons. The Bidder must provide their pricing as requested utilizing the various pricing methodologies specified. **The Bidder/Vendor Partner must agree that they will not offer or provide a better price to any individual entities or cooperatives with equal or lesser volume than that through AEPA.** Please note the following that relate to pricing:

1. **Primary Pricing Strategies:** All Bidders will be required to submit "Primary Pricing" in the form of either "Catalog Pricing" or "Line-Item Pricing" or a combination of these two pricing strategies as defined in Part B, bid specifications. Bidders are also encouraged to offer OPTIONAL pricing strategies including "Hot List" and "Volume Discounts".
 - a. **Catalog Pricing:** Catalog pricing is utilized when the products and/or services solicited are clearly identified with set and specific characteristics, attributes and configurations that are identifiable as a stand-alone single unit and can be listed and priced as a single unit with options that can be added to enhance and/or improve its operation and functionality. The Bidder offers a fixed discount(s) off retail price, catalog price, published price or list price. The discounts may be for the entire commercially available catalog, for specific products, product lines, manufacturers or category of products as determined by the Bidder.
 - i. **Discounts:** Discount offers must clearly identify percent of discount to apply to a commercially available catalog, manufacturer, MSRP, retail or nationally published price lists. Bidders shall identify and stipulate if the discounts apply to the entire catalog/price list, specific product lines, manufacturers and/or categories of products. Bidder shall agree that there will be no reduction in discount(s) during the term of the contract.
 - ii. **New Catalogs/Price Changes:** New catalogs and corresponding nationally published price lists may be submitted throughout the term of the contract and

shall be submitted to the AEPA Category Committee for review prior to release to all AEPA Member Agencies. Prices may change based on manufacturer's price changes, new published pricing or price lists, but the original discount bid shall remain firm for the duration of the contract.

- iii. **Core List:** In a Catalog Priced bid, a category (i.e. office supplies) may include a "core list" which contains a selection of the most commonly used products/services with the expectation that a deeper discount would be bid for these items. If a new catalog and price list is published during the contract term, the original discounts shall be applied to the new published prices to establish the AEPA price for these core items.
 - iv. **Product Addition/Discontinuation:** New products, within the same scope of work, may be added at the established percentage discounts at any time. Discontinued products may be dropped at any time during the year. In the event a Core item is discontinued by the manufacturer during the term of the contract, Vendor Partner is required to add a functionally equivalent substitute at the same discount structure.
- b. **Line-Item Pricing:** Line-item pricing is utilized when products and/or services that are broken down in detail by element, component, product categories, product type and each product and/or service is presented as an individual item which needs to be combined with other items to make up a final project or solution. The Bidder offers firm pricing for specific line items in response to this bid; a project's cost is derived by the Vendor Partner preparing and providing a quote based on the project's terms, conditions and requirements based on the line item pricing provided in the bid. The information provided in this bid for each item includes: Product Category, Product Description, Manufacturer, Manufacturer SKU, Vendor SKU, Unit of Measure, Item List Price, AEPA Bid Price.
- i. **Fixed prices:** Prices bid shall be firm until each anniversary date of contract, unless there is an occurrence of one or more economic price adjustment contingencies outlined in the bid. Fixed price offers shall include prices for any and all items.
 - ii. **Routine Price Adjustments (Without Economic Price Adjustment):** Vendors may request adjustments to the prices by submitting a fully documented written request to the AEPA Category Committee Chairperson. The request must specifically detail and document the cause and/or reason for price changes and include any supporting documentation (manufacturer's letter, indexes, etc.). All price changes require approval by the AEPA Category Committee and Member Agencies.
 - iii. **Unpredictable Economic Price Adjustment:** If economic price adjustment contingencies occur, Vendor Partner may submit a fully documented request (manufacturer's letter, indexes, etc.) for price adjustment to AEPA Category Committee for review and approval by the committee and the AEPA Member Agencies. The documentation must substantiate the cause and/or reason for the requested price increase and demonstrate that it was unpredictable at the time of bid submittal and/or contract renewal and out of the Vendor Partner's control. Pricing will take effect thirty (30) days after approval and acceptance.
 - iv. **New Products/Services:** Vendor Partner may submit new products or technologies that are within the original scope of work for the bid, to be added to the contract pending review and approval of the AEPA Category Committee. Requests should be submitted to the AEPA Category Committee for review and written approval.
- c. **Automated System for Pricing (ASP):** The method consisting of an ASP and/or software application (e.g. RSMean) that is self-contained and consists of a turn-key solution that includes a complete line-item listing of all of the products, supplies, materials, equipment, services, accessories and options with their description, specifications, terms, conditions and associated pricing for each item, sub-assemblies and/or assemblies. The Bidder provides a percent of discount or fixed multiplier/factor to be applied to total project cost to allow for individual state conditions and requirements and to arrive at the AEPA price.

- d. **RSMeans (Construction Related Bids only):** It is important for Vendor Partners to breakout all costs (quantity and price) of all items listed under RS Means or an Alternative Pricing method. This includes all quoted items not on the approved AEPA bid submittal. The following are minimum requirements for using RSMeans for quoting projects to AEPA Member Agencies:
- i. The Contractors must use the current year and standard cost data. Only the following cost data titles will be excepted:
 - a. Building Construction Cost Data Book
 - b. Facilities Construction Cost Data
 - c. Facilities Maintenance & Repair Cost Data
 - d. Site Work & Landscape Cost Data Book
 - ii. All work proposed under RSMeans must use RSMeans format, even if subcontractors are used.
 - iii. An RSMeans spreadsheet must be submitted to substantiate the quote given to the AEPA Member Agency. The spreadsheet columns must reveal the full RSMeans number and a sufficient amount of the description. This also applies to change orders.
 - iv. Pricing must be done by Location codes. National Average will not be allowed. In order to choose the "closest" location code, the first three (3) numbers of the zip code will be used to determine the city location index in the AEPA Member Agency State.
 - v. The AEPA contract holder factor, bonding cost, AEPA discount and taxes if applicable must be shown as separate line items at the bottom of the RSMeans spreadsheet. This information can be shown on a separate summary sheet. The summary sheet must start with the RSMeans spreadsheet total and show the detail for each of the items stated above. This detail will be provided to that AEPA State Agency and the AEPA Buyer as required.
 - vi. All change orders which list items covered by RSMeans must be supported by an RSMeans spreadsheet.
- e. **Alternative Method of Costing:** This method covers any product and/or service not covered by catalog pricing, published price list, line-item price list, automated system for pricing, or is a product and/or service due to the projects or applications specifications, conditions and /or requirements that need to be custom designed, developed, manufactured and/or produced to meet the requirements of an individual, project or sole source. The alternative pricing is calculated as follows:
- i. The Bidder must prepare, issue and receive three written quotes from available suppliers and select the supplier that offers the products and services that meet the stipulated requirements and specifications, offers the best value, and the most cost effective solution. All quotes must be made available upon request.
 - ii. The Bidder must indicate the percent of overhead and /or markup as part of their response to be added to these costs to obtain the normal and customary retail price.
 - iii. The AEPA price is calculated by taking the product and services to cost to the Contractor plus the indicated percent of profit/overhead to equal the normal and customary retail price. The Contractor will then subtract the approved AEPA discount to obtain the AEPA price. Example: item cost \$1,000; percent of profit/overhead of 20% equals retail price of \$1,200; less the AEPA discount of 10% or \$120 equals the AEPA price of \$1,080.
2. **Secondary Pricing Strategies (Catalog Bids only, see Part B for category designation):** Bidders are required to offer Customized Price Lists (Catalog Bids ONLY) and encouraged to offer Hot Lists and Volume Discounts as follows:
- a. **Customized Price List:** Bidders are required to offer customized price lists to Participating Entities for items within the Bidder's Commercially Available Catalog for Catalog Bids ONLY (not pertinent to Line Item Bids). Customized price lists shall be allowed under the following conditions:
 - i. Items within the Vendor Partner's Commercially Available Catalog may be included on

- the customized price list providing they are not already on the Core Item list.
- ii. Items are to be determined by the Participating Entity; Vendor Partner may object to up to ten (10) of the suggested items proposed by the customer and must offer substitutes until an agreement of the customized list is reached.
 - iii. Items on the customized price list shall be sold with an additional discount (deeper than what was originally bid on the non-core or catalog discount)
 - iv. Items may not include special order or customized service products unless agreed to by the Vendor Partner.
- b. **Hot List Pricing:** Bidders are invited, at their option, to offer a selection of products/services, defined as a Hot List, at greater discounts than those listed in the standard catalog or core list discounts. Special, time-limited reductions are permissible under the following conditions: The price reduction is available to all AEPA Member Agencies equally. The price reduction is for a specific time period, no less than thirty (30) days. May be used to discount and liquidate close-out and discontinued products/services as long as those items are clearly labeled as such. The original price for products/services is not exceeded after the time limit. The AEPA Category Committee and all AEPA Member Agencies shall be notified of any special or time limited price reduction. New prices must be on record fifteen (15) days prior to any offer of the new prices being proposed or offered to AEPA Member Agencies and Participating Entities. Pricing for all Hot List items must be updated on the Vendor Partner's online catalog and submitted to all AEPA Member Agencies in an electronic format that can be posted to websites, emailed and shared with Participating Entities/Buyers.
- c. **Volume Price Discounts:** Bidders are encouraged to offer additional pricing discounts that may be offered for a group of agencies in a local geographic area that desire to combine requirements (one time purchase or annual spend), i.e. local city, county, school district(s), etc. and/or for large one time purchases. Additional volume price discounts are permissible under the following conditions: Discounts should be tiered and based on spend ranges as established by the Bidder on the Pricing Forms. Volume determination shall be determined between the Vendor Partner and the individual Buyers on a case-by-case basis. All additional discounts are to be offered equally to all AEPA Member Agencies and Participating Entities and be based on the Volume Price Discounts originally bid providing the same or similar volume commitment, specific needs, terms and conditions, a similar time frame, seasonal considerations and provided the same manufacturer support is available to the Vendor Partner.

Prime Vendor Partner: For the purpose of this bid, a Vendor Partner will be considered a prime Vendor Partner and not a Subcontractor. Any Vendor Partner paid directly by the AEPA Member Agency or Participating Entity is a prime Vendor Partner; a Vendor Partner pays a Subcontractor. Prime Vendor Partners using Subcontractors are responsible for all actions of its Subcontractors.

Procurement Code: All Bidder/Vendor Partner's must make themselves aware of and comply with all federal, state, and local statutes and regulations.

Products and Services

1. **Product Line:** If applicable, contracts will be awarded to Bidders able to provide their complete product line(s) of commodities, supplies, equipment, software and services that meets the scope of work and specifications of this solicitation. Bidders with a published, priced catalog may submit their entire catalog; AEPA reserves the right to select or reject products within the catalog for recommendation without having to award all the contents.
2. **Serial Numbers:** Bids must be for equipment on which the original manufacturer's serial number has not been altered in any way.
3. **Current Products:** All bids shall be for commodities, supplies, equipment, supplies and software in current production; meet or exceed commercial and industry standards; and marketed and provided nationally to the general public and/or educational/governmental agencies.

4. **Construction Products and/or Services:** Are associated with building, erecting, altering, repairing, installing or demolishing in the ordinary course of business any: (1) road, highway, bridge, parking area or related project; (2) building, stadium or other structure; (3) airport, subway or similar facility; (4) park, trail, athletic field, golf course or similar facility; (5) dam, reservoir, canal, ditch or similar facility; (6) sewage or water treatment facility, power generating plant, pump station, natural gas compressing station or similar facility; (7) radio, television or other tower; (8) shaft, tunnel or other mining appurtenance; (9) electrical wiring, plumbing or plumbing fixture, gas piping, gas appliances or water conditioners; (10) air conditioning conduit, heating or other similar mechanical work; or similar work, structures or installations; (11) leveling or clearing land; (12) excavating earth; (13) drilling, wells of any type, including seismographic shot holes or core drilling; and similar work, structures or installations.
5. **Services:** Are defined as the furnishing of labor, time or effort by a Vendor Partner not involving the delivery of a specific tangible product other than reports and other materials which are merely incidental to the required performance.
6. **Professional Services:** Services relating to architects, archeologists, engineers, surveyors, landscape architects, medical arts practitioners, scientists, management and systems analysts, certified public accountants, registered public accountants, lawyers, psychologists, planners, researchers, educational specialist, construction managers and other persons or businesses providing similar professional services, which may be designated as part of this solicitation.
7. **Peripheral & Optional Items:** Bidder can include various peripheral products, equipment, accessories, services, deliverables and related items that are associated with and function with the primary offering. Optional equipment or products may be added to the contract during the term of the contract. AEPA reserves the right to accept or reject such offerings under the following conditions: the enhancement is recommended by AEPA and approved by the Member Agency; the option is priced at a discount similar to other options; and the option is an enhancement to the unit.
8. **Descriptive Literature and Brand Names:** All bids are to include a complete set of the manufacturer's descriptive literature regarding the commodities, supplies, materials, equipment and software offered. Brand names, trade names and/or catalog numbers used in the solicitation will be intended to describe and identify the type, level and quality of products, equipment and software being requested.
9. **Discontinued Products:** If a product or model is discontinued by the manufacturer, Vendor Partner may substitute a new product or model if the replacement product meets or exceeds the specifications and performance of the discontinued model and if the discount is the same or greater than the discontinued model.
10. **Product Specifications:** This solicitation is designed to enable a Bidder to satisfy a requirement for a commodity, supply, material, equipment, software, process, or service. A specification may be expressed as a standard, a part of a standard, or independent of a standard; by specifying a manufacturer's brand and model. No specification is intended to unnecessarily limit competition by eliminating items capable of satisfactorily and/or meeting the actual needs of the procurement. When a brand name product is specified and is only available for a single source, Bidders are encouraged to offer alternative products which they believe to adhere to and comply materially, functionally and operationally equal to or better than the brand name product specified. Any Bidder believing a specification is unnecessarily restrictive, shall indicate such in the form of a question during the solicitation process and prior to bid due date. The fact that a manufacturer or supplier chooses not to produce or supply the commodity, supply, material, equipment, software or services to meet these specifications will not be considered sufficient cause to adjudge these specifications as restrictive. If the Bidder deviates from these specifications, reasons must be stated for such deviation and state why, in their opinion, the commodity, supply, material, equipment, software or services they bid will render equivalent reliability, coverage, performance and/or service. Failure to detail all such deviations may comprise sufficient grounds for rejection of the entire bid.
11. **Quality:** Unless otherwise modified elsewhere in this solicitation, Vendor Partner warrants the commodities, supplies, materials, equipment, and services delivered as stipulated in the Buyer's

purchase order/contract, shall be: of a quality to pass without objection in the industry and professional standards normally associated with them; fit for the intended purpose(s) for which they are used; of even kind, quantity and quality within each unit and among all units, within the variations permitted by the contract; adequately offered, presented, delivered, accomplished and complete as the contract may require; and conform to the written promises and/or oral affirmations of fact made by Vendor Partner.

Product Information, Catalogs and Price Lists: Bidders shall include an electronic copy of the latest edition of the commercially available catalog and price lists that the discount will be applied to with the bid response. Throughout the term of the contract, Vendor Partner(s) shall furnish all AEPA Member Agencies and their Participating Entities with copies of approved commercially available catalogs and price lists in the format desired (electronic, paper, online shopping cart, etc.).

Progress Payments: Progress payments are allowed on purchases for goods and services under the following conditions: The Buyer and the Vendor Partner agree to the terms of the progress payments prior to issuing a purchase order; the purchase order describes the amounts to be paid and the date of payment; the Buyer has a satisfactory method of verifying progress described in writing in a letter or on the purchase order; that payments will only be made when actual goods and/or services are verified/received; and that any such payments be made in full compliance of Buyer's local board rules and any and all other applicable state rules and regulations.

Protests: Under this public procurement and AEPA's Solicitation, any Bidder who is aggrieved in connection with this procurement, can file a protest in accordance with (1) AEPA's Solicitation Document; (2) AEPA's Policies and Procedures; and (3) AEPA Member Agency's State Procurement Code and Board Policies. Venue for any and all legal actions regarding or arising out of the transactions covered herein shall be solely in the court of jurisdiction located in the state and county of the AEPA Member Agency and will govern any resulting transactions.

1. **Procurement Phases:** AEPA's solicitation process is broken down into three (3) phases. Any Bidder who is aggrieved in connection with any of the three (3) procurement/solicitation phases listed below and/or any functions or activities associated with each shall file their protest with the AEPA representative indicated below.
 - a. **Bid Due Date:** The preparation and contents of the solicitation, its terms, conditions and specifications, the notification, distribution of solicitation documents and addendums (date published through the bid due date and time).
 - b. **AEPA Approval:** The receiving, opening, recording, evaluating, recommending and approving Bidders to be considered for AEPA approval and/or actions relating to contract renewal and extension. (Date received and opened through date of individual contract award and future renewals).
 - c. **Contract Award:** The awarding, implementing and administering of resulting contracts and the disclosure of confidential data. (Date individual contracts awarded by AEPA Member Agencies or 120 days from AEPA approval).
2. **Protest contents:** Protests shall be in writing and must be filed with the appropriate AEPA represented below. A protest must include:
 - a. The name, address and telephone number of the protester;
 - b. The original signature of the protester or its representative;
 - c. Identification of the procurement function and/or contract activity with the solicitation or the contract number;
 - d. A detailed statement of the factual grounds or legal basis for the protest;
 - e. Supporting exhibits, evidence or documents to substantiate any claim unless not available within the filing time, in which case, the expected availability date shall be indicated; and
 - f. The form of relief requested.
3. **Protest Submittal:** Protester shall submit the bid protest in accordance with the requirements of the above three (3) procurement functions immediately or within ten (10) days of the date the protester knows or should have known the basis of the protest per the following:

- a. Bid Due Date: Knows or should have known the basis of the protest upon the bid due date or ten (10) days after the bid due date, send protest to Bid Question Coordinator (bid-committee@aepacoop.org).
 - a. AEPA Approval: Knows or should have known the basis of the protest upon notification from AEPA of the bid category approval, send protest to AEPA President (protests@aepacoop.org).
 - b. Contract Award: Knows or should have known the basis of the protest or ten days after the notification from the AEPA Member Agency award, send protest to Individual AEPA Member Agency; see AEPA Member Agency information sheet.
4. **Protest Resolution:** Protest shall be resolved, in accordance with AEPA's Board Policies, Procedures and/or the appropriate state statutes where the AEPA Member resides. It is the intent of AEPA that all bid protest decisions from the point a bid has been published through contract approval or rejection, will be resolved by AEPA. Bid protests concerning contract award by AEPA Member Agencies will be resolved by the respective AEPA Member Agency.
 5. **Protest Costs:** The losing party to the protest shall be responsible for the reasonable and justifiable costs of the protest. The protest costs shall be based on the costs and expenses incurred by the AEPA and its Member Agencies, including but not limited to staff salaries, attorneys' fees, hearing, reproduction, transcription and travel costs.

Provisions Required by Law: By submitting a response to this solicitation, bidders are acknowledging they have conducted and performed the required research to make themselves aware and knowledgeable of all federal, state and local laws/statutes that are referenced herein, may pertain to and/or govern the procurement activities and transactions covered by this bid. These provisions of law and any clause required by law that is associated with and relates to this bid and any resulting contract will be read and enforced as though it were included herein.

Public Purchase: An easy-to-use platform that provides Bidders with the automatic notification of open solicitations, automatic notification of answered questions and issued addenda, and a way to electronically submit an organization's solicitation response. All changes, updates, uploads, and downloads are time stamped and logged as part of the solicitation process.

Public Record: All bids submitted to this invitation shall become the property of the AEPA and will become a matter of public record, available for review, subsequent to the bid due date. Bids may be viewed, by appointment only, at the Oakland Schools, 2111 Pontiac Lake Road, Waterford, MI 48328, under the supervision of the AEPA Executive Director or his/her designee, from 8:30 a.m. to 3:30 p.m., Monday through Friday. Within fifteen days, the Bid Receipt Summary Report will be posted to the AEPA website (www.aepacoop.org).

Questions: Inquiries and questions related to this solicitation, must be submitted online in Public Purchase per IFB and be submitted as follows:

1. From the time the solicitation is published until the deadline for questions for Bidders, questions should be submitted online via Public Purchase.
2. From the time bids are opened but prior to the approval of the contract by AEPA, questions should be submitted to bid-committee@aepacoop.org.
3. After notification of AEPA contract approval, questions should be submitted via email to questions@aepacoop.org.
4. Once a contract has been awarded by an individual AEPA Member Agency any inquiries and questions relating to contract implementation, execution, transactions and/or concerns/issues occurring within that state should be addressed to the individual AEPA Member Agency.

Reporting: Vendor Partners are required to submit quarterly detailed sales reports to all AEPA Member Agencies. Access to reports will be granted after contract approval. If there are no sales, \$0 reports are required.

Right to Assurance: Whenever one party to this contract in good faith has reason to question the other party's intent to perform, he/she may demand that the other party give a written assurance of this intent to perform. In the event that a demand is made and no written assurance is given within ten (10) days, the demanding party may treat this failure as an anticipatory repudiation of the contract.

Right to Request Additional Information: AEPA, and its respective bid representatives, reserves the right to request any additional information during the procurement process that might be deemed necessary to better understand the submitted bid response including, but not limited to, clarifying questions. Bidders may be requested to submit such answers in writing but will not be allowed to change or alter their bid.

Safety Measures: Vendor Partners shall take all necessary precautions for the safety of employees on the worksite, and shall erect and properly maintain at all times, as required by job conditions and progress of the work, all necessary safeguards for the protection of the workers and public. They shall post danger-warning signs against the hazards created by their operation and work in progress. Proper precautions shall be taken pursuant to state law and standard construction practices in order to protect workers, the general public and existing structures from injury or damage.

Safety Standards: All items supplied on this contract shall comply with the current applicable Occupational Safety and Health Standards, the National Electric Code, and the National Fire Protection Association Standards.

Severability: The provisions of this contract are severable to the extent that any provision or application held to be invalid shall not affect any other provision or application of the contract that may remain in effect without the invalid provision or application.

Substance Use & Conduct: All Vendor Partners and Subcontractors must adhere to local substance (alcohol, drug, smoking, etc.) and conduct (dress code, language, parking, etc.) policies while on AEPA Member Agencies and Participating Entities premises.

State Agency: means any department, commission, council, board, committee, institution, legislative body, agency, government corporation, educational institution or official of the executive, legislative or judicial branch of the government of this state.

Survival: All applicable software license agreements, warranties or service agreements that were entered into between Vendor Partner and Buyer under the terms and conditions of the Contract shall survive the expiration or termination of the Contract. All Purchase Orders issued and accepted by Vendor Partner shall survive expiration or termination of the Contract.

Suspension or Debarment Status: If within the past five (5) years, any Bidder has been disbarred, suspended or otherwise lawfully precluded from participating in any public procurement activity with a federal, state or local government, the Bidder must include a letter with its response or bid setting forth the name and address of the public procurement unit, the effective date of the suspension or debarment, the duration of the suspension or debarment, and the relevant circumstances relating to the suspension or debarment. Any failure to supply such a letter or to not disclose in the letter all the pertinent information may result in the cancellation of any resulting contract. By signing the bid section, the Bidder certifies that no current suspension or debarment exists.

Tare: If the Vendor Partner requires the Buyer to pay for shipping, the weight of the empty container and any material used for packing shall be of the lightest weight practical for safe delivery of the contents.

Taxes: Different jurisdictions taxing authorities have different tax laws, rules, regulations and processes, therefore, prices offered will not include applicable federal, state and local taxes. All applicable taxes must be listed as a separate item on all cost proposals, invoices.

Term of Contract and Extensions: The initial term of the contract shall be for up to fifteen (15) months and will commence on the date as indicated by each Participating Member Agency on the Acceptance of Bid and Contract Award (Form B). The contract shall continue in accordance with the dates stipulated in the Bid and Timeline schedule located in Part A of this bid unless terminated, cancelled or extended. By mutual written agreement, the contract may be extended for three additional 12-month periods, ending on the last day of February. AEPA may choose to recommend the contract extension. If so recommended, an individual Member Agency may choose, at their sole discretion, to extend the contract. In the event AEPA does not recommend or approve a contract extension, a Member Agency reserves the right to offer month-by-month extensions not to exceed six (6) months until a new contract is awarded by that Member Agency.

Termination by Non-Approval of AEPA: AEPA Member Agencies on annual basis assess, evaluate and review existing AEPA vendors to determine if the organization as a whole desire to extend its approval of those vendors. If an existing AEPA vendor's approval is not extended for an additional term, the AEPA Member Agencies can not extend the dis-approved vendor's contract. (See Term of Contract and Extensions)

Termination by AEPA Member Agency: An AEPA Member Agency may cancel any contract secured by the solicitation without any further obligation if any person significantly involved in initiating, negotiating, securing, drafting, or creating the contract on behalf of the AEPA Member Agency is or becomes, at any time while the contract or any extensions of the contract is in effect, an employee of, or a consultant to any other party to this contract with respect to the subject matter of the contract. Such cancellation shall be effective when the parties to this contract receive written notice from the AEPA Member Agency unless the notice specifies a later time. Cancellation by one AEPA Member Agency does not require other Agencies to cancel their contracts.

Termination for Convenience: AEPA Member Agency reserves the right to immediately terminate this contract, without penalty or recourse, in whole or in part, if the AEPA Member Agency determines that termination is in the best interest of Participating Entities. The Vendor Partner, after receipt of a "Notice of Termination," shall not accept any new orders after the termination date specified in the notice. Any termination shall have no effect on projects that are in progress at the time the cancellation is received by the AEPA Member Agency. Vendor Partner shall be entitled to receive just and equitable compensation in accordance with applicable contract pricing for work in progress, work completed and materials accepted before the effective date of the cancellation. The Vendor Partner will not be reimbursed for any anticipated profit. The AEPA Member Agency reserves the right to cancel, or suspend the use thereof, any contract resulting from this IFB if the Vendor Partner files for bankruptcy protection, or is acquired by an independent third party. Vendor Partner may cancel this contract upon written notice to the AEPA Member Agency prior to the intended termination date (or on the yearly anniversary of the bid). Any termination shall have no effect on projects that are in progress at the time the cancellation is received by the AEPA Member Agency.

Termination for Default: If either party is in default under this contract, it shall have an opportunity to cure the default within the time indicated (ten business days in most states) after it is given written notice of default by the other party, specifying the nature of the default. Upon receipt of the notice of default, the defaulting party shall have ten business days to provide a satisfactory response to the AEPA Member Agency. Failure on the part of the defaulting party to adequately address all issues of concern may result in contract termination. If the default is not cured within the time specified in the notice of default, the non-defaulting party shall have the right, in addition to all other remedies at law or equity, to immediately terminate this contract. Failure to complain of any action, non-action or default under this Agreement shall not constitute a waiver of any of the parties' rights hereunder. The AEPA Member

Agency reserves the right to terminate this contract, or any part hereof, for cause in the event of any default by the Vendor Partner, or if the Vendor Partner fails to comply with any contract terms and conditions, or fails to provide the AEPA Member Agency, upon request, with adequate assurances of future performance. In the event of termination for cause, the AEPA Member Agency shall not be liable to the Vendor Partner for any amount for supplies or services not accepted, and the Vendor Partner shall be liable to the AEPA Member Agency or any Participating Entity for any and all rights and remedies provided by law. If it is determined that the AEPA Member Agency improperly terminated this contract for default, such termination shall be deemed a termination for convenience. The AEPA Member Agency will issue written notice to the Vendor Partner for acting or failing to act in any of the following:

1. The Vendor Partner provides material that does not meet the specifications of the contract;
2. The Vendor Partner fails to adequately perform the services set forth in the specifications of the contract;
3. The Vendor Partner fails to complete the work required or to furnish the materials required within a reasonable amount of time;
4. The Vendor Partner fails to make progress in the performance of the contract and/or gives the AEPA Member Agency reason to believe that the Vendor Partner will not or cannot perform to the requirements of the contract;
2. The Vendor Partner fails to extend lower pricing that has been offered to another customer or cooperative that have equal or lesser volume.
3. The Vendor Partner fails to observe any of the terms and conditions of the contract;
4. The Vendor Partner fails to follow the established procedure for purchase orders, invoices and receipt of funds as stipulated by the AEPA Member Agency.

Termination for Non-Appropriation: Any individual Buyer's procurement/contract covered by this bid and executed in accordance with resulting contract may be terminated if insufficient appropriations and/or authorizations do not exist due to changes in state or federal law, or because of court order, or because of insufficient appropriations made available to the Buyer's governing board and/or its State Legislature. Such termination will be effected by sending fifteen (15) days written notice to the Vendor Partner. The Buyer's decision as to whether sufficient appropriations and authorizations are available shall be accepted by the Vendor Partner and shall be final.

Title and Risk of Loss: The title and risk of loss of material or service shall not pass to the Buyer purchasing the material or services until it actually receives the material or service at the point of delivery, unless otherwise provided within this document.

Trade-in Equipment: Equipment for trade-in shall be dismantled by the Vendor Partner and removed at its expense. The conditions of the trade-in equipment at the time it is turned over to the Vendor Partner shall be the same as when the original agreement was made, except as affected by normal wear and tear from use between the time of the bid and the trade-in. Values placed on trade-in products are between the Buyer purchasing the new unit and the Vendor Partner.

Type of Bids: Due to the various types, kinds and levels of products and services solicited by AEPA in its IFBs; the various pricing methodologies and/or methods utilized and offered to price the various products and services offered; and the type of contracts that results from any one of AEPA's/bids, AEPA has established the following two (2) types of bids.

1. Catalog Bid: A catalog bid is utilized when the products and /or services solicited are clearly identified with set and specific characteristics, attributes and configurations that are identifiable as a stand-alone single unit and can be listed and priced as a single unit with options that can be added to enhance and/or improve its operation and functionality. The Bidder offers a fixed discount(s) off retail price or prices in a Commercially Available Catalog. The discounts may be for the entire Catalog for specific products, product lines, manufacturers or category of products as determined by the Bidder. See the Pricing section for detailed information on Catalog pricing.

2. **Line Item Bid:** A Line-item bid is utilized when the products and services solicited cannot be identified or listed as a single unit; consists of a number of different variable and configurations, it is necessary to identify the specific project or application; the end product or solution is made of individually priced elements or components and the end product's or solutions' cost is derived by the Vendor Partner specially prepared and providing a quote based on the project's terms, conditions and requirements. See the Pricing section for detailed information on Line-Item pricing.

Vendor Partner: Bidder who has been approved and awarded a contract for the delivery of construction, tangible personal property, supplies, or services in response to this IFB.

Vendor Partner Contact: Vendor Partner will designate one individual who will represent them to the AEPA, its AEPA Member Agencies during the contract period. This contact person will correspond with each AEPA Member Agency for technical assistance, problems, or questions that may arise. If other staff, distributors and/or independent Vendor Partners will be performing the sales or support functions for different geographical areas (states), Vendor Partner shall include instructions and contact information that can be distributed to AEPA Member Agencies upon approval of this bid.

Warranty: Vendor Partner warrants that all commodities, supplies, materials, equipment, software and service delivered under this contract shall conform to the specifications of this contract. All items should carry a warranty equal to the intended life cycle or a minimum 12-month manufacturer's warranty that includes parts and labor unless otherwise specified and agreed to. The manufacturer has the primary responsibility to honor a manufacturer's warranty; a distributor or dealer agrees to assist the purchaser reach a solution in a dispute with the manufacturer over a warranty's terms. Any extended manufacturer's warranty will be passed on to the Buyer. For example, if a voice board has a three-year warranty, but the board is in a turnkey system that has a one-year warranty, the voice board's three-year warranty must be honored by the manufacturer and the Vendor Partner. All extended warranties must be passed on, without exception. If, upon discovery, the Vendor Partner charges a Buyer for a replacement part that the Vendor Partner actually received at no cost under a warranty, the Vendor Partner will rebate the amount billed and the Buyer reserves the right to cancel the contract.

**Invitation for Bid
AEPA IFB #020-E
LAWN & GROUNDSKEEPING EQUIPMENT, SUPPLIES & SERVICES**

Part B – Technical Specifications

Table of Contents

1.	<u>Scope of Bid</u>	1
2.	<u>Type of Bid</u>	2
3.	<u>Anticipated AEPA Member Agency Participation</u>	2
4.	<u>Anticipated Volume</u>	3
5.	<u>Voluntary Pre-Bid Conference Call</u>	3
6.	<u>Glossary of Terms and Abbreviations</u>	4
7.	<u>Special Terms and Conditions</u>	4
8.	<u>Standard Specifications</u>	6
9.	<u>Product Category Specific Specifications</u>	6
10.	<u>Pricing</u> – See Pricing section in Part A – General Terms & Conditions for details	7
11.	<u>Evaluation</u>	9

1. Scope of Bid

AEPA is seeking qualified, experienced contractor(s) who possess the necessary resources and capabilities to acquire, deliver and perform the required supplies, materials, equipment and services to all participating member states (up to 28) in the category of **Lawn & Groundskeeping Equipment, Supplies & Services**. This invitation seeks bids for equipment, supplies, parts, and services for procurement by different types of educational, governmental, and public-benefit institutions as follows:

- a. Equipment, including but not limited to zero-turn mowers; ride-on mowers; wide-area mowers; stand-on mowers; walk-behind mowers; attachable devices for cutting, aeration, and dethatching; string edgers and trimmers; chain saws; leaf and debris blowers; California compliant mowers; and utility vehicles and tractors — all offered, described, and priced in a Commercially Available Catalog.
- b. Parts and supplies, including, but not limited to replacement parts, parts for customizable options and add-ons, repair parts, engine and transmission parts, tires, blades, tines, cosmetic enhancement parts, sprinkler and irrigation parts, electronic control devices, and system parts.
- c. Types of services may include, but are not limited to repair services, extended maintenance contracts, landscaping and turf management software, consulting, assessments, turf management, environmental services, leasing, equipment rentals, training and professional development, and customer service.

All products offered to be sold or leased must be considered new, unused, of the latest design and technology and from the most current and popular turf and groundskeeping product lines available. Bid pricing for equipment must be for the latest available year’s model. Rental equipment need not be new.

AEPA and Member Agencies prefer a single vendor with a comprehensive array of products. However, because of the unique nature of lawn and groundskeeping products and services, Member Agencies may

consider multiple awards, if the lowest, best-value bids come from Bidders whose business concentrates on a subset of equipment or provides a better pricing value in the categories of 1) Small Mowers & Grounds Tools, 2) Stand-On Mowers, 3) Turf Vehicles & Attachments, 4) Walk-Behind Mowers, 5) Wide-Area Mowers, or 6) Zero-Turn Mowers. In addition, AEPA and Member Agencies reserve the right to make multiple awards in cases where more than one vendor is necessary to meet the scope of equipment needed; multiple vendors are needed to serve the geographic needs of Member Agencies; or where the majority of offerings within bidders' Commercially Available Catalog is unique from one to another.

2. Type of Bid

AEPA requests Bidders to submit primary pricing in the form of "catalog pricing." This category is described in the form checked below. An explanation of each can be found in the table below. Additional information on permissible pricing strategies can be found in Part A – General Terms and Conditions under "Pricing."

This bid is considered a:

YES	NO	TYPE OF BID
X		CATALOG: A catalog bid is utilized when the products and/or services solicited are clearly identified with set and specific characteristics, attributes and configurations that are identifiable as a stand-alone single unit and can be listed and priced as a single unit with options that can be added to enhance and/or improve its operation and functionality. The Bidder offers a fixed discount(s) off retail price or prices in a Commercially Available Catalog. The discounts may be for the entire Commercially Available Catalog, for specific products, product lines, manufacturers, or category of products as self-determined by the Bidder. See Pricing section for detailed information on Catalog Pricing.
		LINE ITEM: A line-item bid is utilized when the products and services solicited cannot be identified or listed as a single unit; consists of a number of different variables and configurations, it is necessary to identify the specific project or application; the end product or solution is made of individually priced elements or components and the end product's or solution's cost is derived by the Vendor Partner specially prepared and providing a quote based on the project's terms, conditions and requirements. See Pricing section for detailed information on Line-Item Pricing.

3. Anticipated AEPA Member Agency Participation

State	Participate? Yes/No/ Undecided	Other States Member Sells In
California	Yes	AZ, NV
Colorado	Yes	
Connecticut	Yes	MA, ME, NH, NY, RI, VT
Florida	Yes	AL, GA
Georgia	Yes	
Illinois	No	
Indiana	Yes	
Iowa	Yes	IL, SD
Kansas	Yes	OK
Kentucky	Yes	AL, GA, LA, MS, NC, SC, TN, WV
Massachusetts	Yes	
Michigan	Yes	
Minnesota	Yes	SD
Missouri	Yes	AR, IL, LA, SD
Montana	Yes	ID
Nebraska	Yes	
New Jersey	Yes	
New Mexico	Yes	
North Dakota	Yes	

Ohio	Yes	
Oregon	Yes	
Pennsylvania	Yes	DE, HI, MD, NY
Texas	Yes	
Virginia	Yes	
Washington	Yes	AK, ID
West Virginia	Yes	
Wisconsin	Yes	
Wyoming	Yes	SD, UT
Total	27	

Please note that individual AEPA Member Agencies that have indicated that they intend to participate in any contract approved under this solicitation, does not guarantee or mean that the individual AEPA Member Agency will enter into a contract with any AEPA approved Vendor Partner. Each AEPA Member Agency will make that determination after reviewing Vendor Partner responses and AEPA's recommendation for acceptance and bid award. The AEPA Member Agency's contracting decision shall be final.

4. Anticipated Volume

This IFB for Lawn & Groundskeeping Equipment, Supplies & Services is a new a category for AEPA. The resulting bid will be an Indefinite Delivery, Indefinite Quantity (IDIQ) contract(s). AEPA Member Agencies estimate approximately \$5 million in sales in the first contract term, depending upon demand and the cooperation of the Awarded Vendor(s). AEPA Member Agencies anticipate that purchase volumes will increase over the course of contract years two (2) through four (4). This information is provided as an aid to Bidders in preparing responses only. It is not to be considered a guarantee of volume under this IFB. The successful Vendor Partner's discount and pricing schedule shall apply regardless of the volume of business under the contract.

5. Voluntary Pre-Bid Conference Call

AEPA will host a voluntary pre-bid conference call on Wednesday, August 14, 2019, for any interested Bidders or potential Bidders. The conference call times are set in the following schedule for each of the four contiguous United States time zones. No pre-registration will be required. Recording of the conference call will be posted on the AEPA Website.

Voluntary Pre-Bid Conference Call Schedule (All Categories)

IFB	Eastern	Central	Mountain	Pacific
020-A Natural and Synthetic Surfaces for Sport Fields, Tracks, Courts, Playground and Landscaping Applications	11:00 AM	10:00 AM	9:00 AM	8:00 AM
020-B Carpet & Resilient Flooring	11:30 AM	10:30 AM	9:30 AM	8:30 AM
020-C Digital Resources & Instructional Materials	12:00 PM	11:00 AM	10:00 AM	9:00 AM
020-D Facility Management Software	12:30 PM	11:30 AM	10:30 AM	9:30 AM
020-E Lawn & Groundskeeping Equipment, Supplies & Services	1:00 PM	12:00 PM	11:00 AM	10:00 AM
020-F Digital Display Solutions	1:30 PM	12:30 PM	11:30 AM	10:30 AM
020-G Vehicles – Cars, SUVs, Crossovers, Light Duty Trucks, Vans, Police and Public Safety	2:00 PM	1:00 PM	12:00 PM	11:00 AM

Join Zoom Meeting: <https://zoom.us/j/770090798>

Conference Call Number: +1 929 436 2866

Meeting ID: 770 090 798

6. Glossary of Terms and Abbreviations

Abbreviations and Acronyms for Standards, Regulations and Specifications: Where abbreviations and acronyms are used in specifications or other contract documents, they shall mean the recognized name of the organizations responsible for the standards and regulations in the following list. Any Internet links listed here are subject to change and are believed to be accurate and up-to-date as of the date of the contract documents.

- a. **Commercial Mower:** In specifying the standard for “Commercial Mowers,” AEPA, distinguishes commercial mowers from consumer mowers. Commercial Mowers include cutting decks made of higher gauge steel, alloy spindles, greater horsepower engines, more durable belts, and, often, hydrostatic controls. Life-span of the machines are longer and can be measured in hours, and often machines will include an hours meter.
- b. **Reel Mower:** A “Reel Mower” is a mower in which the blades spin vertically (north to south) and use a scissor-style action to cut the blades of grass. A reel mower usually has between three and seven blades.
- c. **Rotary Mower:** A “Rotary Mower” is a mower in which the blade spins horizontally (east to west) and often uses a sucking and tearing action to cut blades of grass.
- d. **Sit-On Mower:** A “Sit-On Mower” is a ride-on lawnmower or a tractor mower on which the operator is seated, unlike mowers which are pushed or towed. Most often the cutting deck for a Sit-On Mower is engineered with a front-end placement to make the machines more maneuverable, as opposed to a consumer lawn tractor with a mid-mounted deck. Some Sit-On Mowers have zero-turn capability, but not exclusively, so some mowing models can fit into multiple category types.
- e. **Walk-Behind Mower:** A “Walk-Behind Mower” is a self-propelled machine powered by a transmission. It features hand controls for control and navigation and lends itself to efficient maneuverability.
- f. **Stand-On Mower:** A “Stand-On Mower” includes a platform for the operator to stand upright, enabling a more ergonomic operating experience. The machine usually includes a bail-out function that allows the operator to step off, thereby forcing the motor to stop for greater safety, especially on slopes and around obstacles. Weight shifting in the standing position provides more mower maneuverability.
- g. **Zero-Turn Mower:** The term “Zero-Turn” describes the capability of a mower to make 360-degree turns with a turning radius of zero inches. This enables a mower to better reverse course saving fuel and labor, trim more efficiently, and negotiate obstacles. Multiple types of mowers can have zero-turn capability, so some Zero-Turn machines can fit into multiple category types.
- h. **California Compliant:** The California Air Resources Board (CARB) has established emissions regulations that apply to any type of lawn mower sold in the state. In addition, the existing regulations also seek to reduce fume leakage. In 2020, CARB will consider additional, stricter rules that apply to small engines. If adopted by CARB, the new rules will, by default, apply to lawnmowers sold under this contract and all machines sold in California must conform to the new and most restrictive standards. Monitor bulletins and regulations at this website:

<https://ww2.arb.ca.gov/small-road-engine-or-equipment-regulatory-and-certification-documents>.

7. Special Terms and Conditions

Item	Description
7.1	Bid pricing for equipment shall be for those of a brand’s most recently available model year.
7.2	Bidder’s Commercially Available Catalog must include a set of mowers that is California compliant.
7.3	Older model year equipment in stock may be advertised and sold under the discount formula bid against the listed price in the Commercially Available Catalog. See 10. Pricing. 2.B relating to “Hot List Pricing.”
7.4	Awarded Vendor must comply with all governmental and environmental regulations and fees imposed by a Buyer’s state, including any regulations relating, but not limited to, tires, tire disposal, recycle

Item	Description
	fees, air quality emissions, vehicle registration, licensing, and sales tax.

8. Standard Specifications

Item	Description
8.1	The Vendor Partner must have access and legal authority to sell all items listed in its Commercially Available Catalog.
8.2	The Vendor Partner shall maintain a minimum monthly overall average fill rate of 95% or above. Line items that are reordered, backordered, or partially filled are not considered filled line items when calculating this service level.
8.3	Orders must be shipped timely in accordance with the due date stipulated on a buying agency's purchase order. The Vendor Partner will notify the Buyer if product ordered cannot be shipped within the identified time period, whereupon Buyer will have the option to cancel its order or agree to a mutually acceptable delivery date
8.4	Vendor Partners must be a manufacturer or a manufacturer's authorized sales and service dealer for all proposed equipment, parts, and software. An authorized sales and service dealer is defined in this solicitation as one purchasing their products for resell directly from the manufacturer(s) or the manufacturer's approved channels. Products that result from new authorized sales and service dealer arrangements between the Vendor Partner and the manufacturer during the term of this contract may be added and offered through the AEPA contract.
8.5	All charges and components necessary for performance of the contract shall be clearly identified even if such are not specifically addressed in any paragraph or sub-paragraph or form that is a part of this request.
8.6	If the Vendor Partner intends to utilize independent agents/distributors, subcontractors and/or third-party agents to perform and/or provide any part of the products and services offered herein, the Vendor Partner must identify all providers and any and all associated costs with these providers.
8.7	Optional services must be identified separately and must include clear descriptions of proposed services.
8.8	Vendor Partners must provide a product or mix of products and equipment in a manner that will allow Buyers to migrate to emerging technologies/services and between legacy technologies with no penalty charge associated with maintaining the most appropriate selections of goods and services throughout the life of the contract.
8.9	Packing slips shall accompany all deliveries and shall contain Buyer's purchase order number, vendor name and name of article. Cartons, crates, or equipment shall be identified by purchase order number and vendor name.
8.10	Orders not filled and partials shall be indicated on the packing list. Vendor Partner shall inform member of anticipated availability date for unfilled and partial orders.
8.11	All products sold by the Vendor Partner must be new. Vendor Partner may offer reconditioned products as a Voluntary Alternate; such items shall be marketed and labeled as being reconditioned. Rental equipment need not be new.
8.12	Products that have a 30-/60-/90-day money back guarantee will be clearly identified in the catalog and on the web site (if applicable).
8.13	Vendor Partner has the option to offer equipment from multiple product lines and manufacturers if a proper pricing discount formula is bid and established and the items are published in its Commercially Available Catalog.
8.14	If the Vendor Partner makes an error in pricing (typographical or photographic error, for example), the Buyer reserves the right to return the product. The Vendor Partner agrees to pay for cost of any returned product due to a pricing error.
8.15	Vendor Partner shall provide a Safety Data Sheet (SDS) for all items sold, if required. A separate sheet shall be provided for each individual item when purchase is made.
8.16	Orders that are \$100 (one hundred) or more shall include shipping in the total price. Vendor Partner shall bid a flat rate for all orders that are less than \$100 regardless of where to be shipped in the continental United States.

9. Product | Category Specific Specifications

Item	Description
9.1	<p>To be responsive, a bidder must respond with a Commercially Available Catalog that contains one or more products in the following categories:</p> <ul style="list-style-type: none"> • Zero-Turn Mowers • Ride-On Mowers • Wide-Area Mowers • Stand-On Mowers • Walk-Behind Mowers • Small Mowers and Power Grounds Tools • Utility Vehicles and Turf Tractors • Attachable Devices for Cutting, Aeration, and Dethatching • California Compliant Mowers • Turf, Irrigation and Equipment Parts and Supplies
9.2	<p>It is desired but is not mandatory that a Bidder's Commercially Available Catalog contain products in the following categories:</p> <ul style="list-style-type: none"> • Compact Utility Loaders • Hover Trimmers • Lawn Striping Kits • Non-Commercial-Grade Lawn Tractors • Robotic Mowers • Snow Blowers • Sprayers • Sweepers • Tillers • Tractors • Trailers • Trenchers • Water Pumps • Other Turf or Groundskeeping Equipment
9.3	<p>Equipment in the categories listed in 9.1 must be Commercial Grade machines, with the exception of the category for "Small Mowers and Power Grounds Tools," wherein consumer quality mowers and grounds tools may be included in the category with an appropriate and distinguishing bid discount.</p>
9.4	<p>To be responsive, every item on the core list must be priced with an applicable formula discount and meet the minimum specifications for the piece of equipment specified.</p>
9.5	<p>The identification of a branded product on the core list is a for-like specification and a representation of the equipment to be evaluated for price and offered for sale. For any product specified with a brand name, a Vendor may bid an equivalent piece of equipment.</p>
9.6	<p>Evaluation of core items related to equivalency shall be for function, not form, while giving priority to the minimization of labor costs related to speed and cutting width. Evaluations for equivalence will not be consider features such as seat comfort, audio-jacks, the presence of hour meters, or machine color. AEPA and Members Agencies shall decide equivalency based on a standard that is commonly applied to all Bidders, and its determination of equivalency shall be final.</p>
9.7	<p>For all items in the rest of the Bidders Commercially Available Catalog, the Bidder must self-identify categories for the items to be sold, whether by brand, type, function, model series, model year, size, etc.</p>
9.8	<p>Each self-identified category must have a corresponding pricing discount formula that will translate into the bid price for evaluation and the maximum sell price to Buying Agencies.</p>
9.9	<p>Awarded Vendor Partner(s) must be able to provide a network of repair facilities reasonably accessible to Buying Agencies or provide on-site repair service.</p>
9.10	<p>Awarded Vendor Partner(s) is responsible for delivering equipment to the ground at site specified on the Purchase Order. Buying Agencies will not be responsible for offloading equipment from trucks, trailers, or train cars.</p>

10. Pricing

AEPA has identified and stipulated the type of bid and the pricing methodologies that are to be utilized to price and submit bid prices. The Vendor Partner agrees that the cost for any item bid or offered on this contract will be uniform for all states, and that any differences in pricing are due to state specific installation and labor costs, AEPA Member Agency's Administrative Fee, or other approved reasons. The Bidder must provide their pricing as requested utilizing the various pricing methodologies specified. **The Bidder/Vendor Partner must agree that they will offer prices equal to or better than what they ordinarily offer to individual entities or cooperatives with equal or lesser volume.** Please note the following that relate to pricing:

1. **Primary Pricing Strategies:** All Bidders will be required to submit "Primary Pricing" in the form of "Catalog Pricing," as defined in Part B, bid specifications. Bidders are also encouraged to offer OPTIONAL pricing strategies including "Hot List" and "Volume Discounts".
 - a. **Catalog Pricing:** Catalog pricing is utilized when the products and/or services solicited are clearly identified with set and specific characteristics, attributes and configurations that are identifiable as a stand-alone single unit and can be listed and priced as a single unit with options that can be added to enhance and/or improve its operation and functionality. The Bidder offers a fixed discount(s) off retail price, catalog price, published price, or list price. The discounts may be for the entire commercially available catalog, for specific products, product lines, manufacturers or category of products as determined by the Bidder.
 - i. **Discounts:** Discount offers must clearly identify percent of discount to apply to a commercially available catalog, manufacturer, MSRP, retail or nationally published price lists. Bidders shall identify and stipulate if the discounts apply to the entire catalog/price list, specific product lines, manufacturers and/or categories of products. Bidder shall agree that there will be no reduction in discount(s) during the term of the contract.
 - ii. **New Catalogs/Price Changes:** New catalogs and corresponding nationally published price lists may be submitted throughout the term of the contract and shall be submitted to the AEPA Category Committee for review prior to release to all AEPA Member Agencies. Prices may change based on manufacturer's price changes, new published pricing or price lists, but the original discount bid formula(s) shall remain firm for the duration of the contract.
 - iii. **Core List:** In this Catalog-Priced bid, a "core list" is included which contains a selection of the commonly used and desired products, published with the expectation that a deeper discount would be bid for these items. If a new catalog and price list is published during the contract term, the original discount formulas shall be applied to the new published prices to establish the AEPA price for these core items.
 - iv. **Product Addition/Discontinuation:** New products, within the same scope of work, may be added at the established percentage discounts at any time. Discontinued products may be dropped at any time during the year. In the event a Core item is discontinued by the manufacturer during the term of the contract, Vendor Partner is required to add a functionally equivalent substitute at the same discount formula structure.
 - b. **Alternative Method of Costing:** This method covers any product and/or service not covered by catalog pricing, published price list, line-item price list, automated system for pricing, or is a product and/or service due to the projects or applications specifications, conditions and /or requirements that need to be custom designed, developed, manufactured and/or produced to meet the requirements of an individual, project or sole source. The alternative pricing is calculated as follows:
 - i. The Bidder must prepare, issue and receive three written quotes from available suppliers and select the supplier that offers the products and services that meet the stipulated requirements and specifications and the most cost-effective solution. All quotes must be made available upon request.
 - ii. The Bidder must indicate the percent of overhead and/or markup as part of their response

to be added to these costs to obtain the normal and customary retail price.

- iii. The AEPA price is calculated by taking the product and services to cost to the Contractor plus the indicated percent of profit/overhead to equal the normal and customary retail price. The Contractor will then subtract the approved AEPA discount to obtain the AEPA price. Example: item cost \$1,000; percent of profit/overhead of 20% equals retail price of \$1,200; less the AEPA discount of 10% or \$120 equals the AEPA price of \$1,080.

2. **Secondary Pricing Strategies (Catalog Bids only, see Part B for category designation):**

Bidders are required to offer Customized Price Lists (Catalog Bids ONLY) and encouraged to offer Hot Lists and Volume Discounts as follows:

- a. **Customized Price List:** When requested, during the course of the contract, Vendor Partners are required to offer customized price lists to Participating Entities for items within the Bidder's Commercially Available Catalog for Catalog Bids ONLY (not pertinent to Line Item Bids). Customized price lists shall be allowed under the following conditions:
 - i. Items within the Vendor Partner's Commercially Available Catalog may be included on the customized price list providing they are not already on the Core Item list.
 - ii. Items are to be determined by the Participating Entity; Vendor Partner may object to up to ten (10) of the suggested items proposed by the customer and must offer substitutes until an agreement of the customized list is reached.
 - iii. Items on the customized price list shall be sold with an additional discount (deeper than what was originally bid on the non-core or catalog discount)
 - iv. Items may not include special order or customized service products unless agreed to by the Vendor Partner.
- b. **Hot List Pricing:** Bidders are invited, at their option, to offer a selection of products/services, defined as a Hot List, at greater discounts than those listed in the standard catalog or core list discounts. Special, time-limited reductions are permissible under the following conditions: The price reduction is available to all AEPA Member Agencies equally. The price reduction is for a specific time period, no less than thirty (30) days. May be used to discount and liquidate close-out and discontinued products/services as long as those items are clearly labeled as such. The original price for products/services is not exceeded after the time limit. The AEPA Oversight Committee and all AEPA Member Agencies shall be notified of any special or time limited price reduction. New prices must be on record fifteen (15) days prior to any offer of the new prices being proposed or offered to AEPA Member Agencies and Participating Entities. Pricing for all Hot List items must be updated on the Vendor Partner's online catalog and submitted to all AEPA Member Agencies in an electronic format that can be posted to websites, emailed and shared with Participating Entities/Buyers.
- c. **Volume Price Discounts:** Bidders are encouraged to offer additional pricing discounts that may be offered for a group of agencies in a local geographic area that desire to combine requirements (one-time purchase, or annual spend), i.e. local city, county, school district(s), etc. and/or for large one time purchases. Additional volume price discounts are permissible under the following conditions: Discounts should be tiered and based on spend ranges as established by the Bidder on the Pricing Forms. Volume determination shall be determined between the Vendor Partner and the individual Buyers on a case-by-case basis. All additional discounts are to be offered equally to all AEPA Member Agencies and Participating Entities and be based on the Volume Price Discounts originally bid providing the same or similar volume commitment, specific needs, terms and conditions, a similar time frame, seasonal considerations and provided the same manufacturer support is available to the Vendor Partner.

3. **Part F - Pricing Workbook**

- a. This bid category has a Core Item List.
- b. Pricing shall be completed on the provided pricing sheets (Microsoft Excel Workbook) with the individual tables to be completed as follows:
 - i. F.1 – Catalog Discount (Required)

- ii. F.2A – Core List Price Schedule (Required) *Additional products offerings may not be added to this form.
 - iii. F.2B – Non-Core Price Schedule (Required)
 - iv. F.3 – Services Price Schedule (Optional)
 - v. F.4 – Volume Discounts
- c. The Catalog Category Discount and the Core Items award will not be split.
- d. Bid pricing will be evaluated on a combination of items from both the Core List and Non-Core List Price Schedules. Pricing evaluation may include other considerations, including the total cost of the acquisition and whether the Proposer’s offering represents the best value. See Evaluation, Approval and Award in Part A – Terms and Conditions for additional information.

11. Evaluation

The AEPA Committee for this category will evaluate bid responses based on the entire response, and according to the criteria detailed in Part A for AEPA’s definition of Responsive and Responsible bids. A recommendation may be made to recommend a single response, or to recommend multiple bidders based on differentiation of product or service between bidders. AEPA will vote as a whole to accept or not accept a committee’s recommendation. Once accepted, each recommended bid response will go to the individual states for contract approval. Please note, pricing evaluation may include other considerations, including the total cost of the acquisition and whether the Proposer’s offering represents the best value. The evaluation committee may consider such factors as life-cycle costs, total cost of ownership, quality, and the suitability of an offering in meeting AEPA members’ needs.

Below is a summary taken from the Evaluation section in Part A, F. Bid Evaluation, Approval and Award:

Evaluation Criteria
Cost Evaluation
Complete Response to Bid
Conformance to Bid Terms and Conditions
Pricing Equal to or Better Than That Offered to Individual Entities or Cooperatives With Equal or Lesser Volume
Quality and Suitability of Products Offered
Marketing Plan
Financial Viability
Demonstrated Track Record of Performance in the Public Marketplace
Value Added attributes

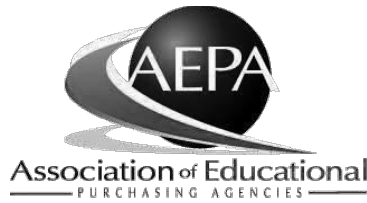

Invitation for Bid
AEPA IFB #020-E
Lawn & Groundskeeping Equipment, Supplies & Services
Part C – Member Agency (State) Terms and Conditions

Table of Contents

1. Member Agency (State) Terms and Conditions.....	1
2. Common Terms and Conditions	1
3. Member Agency General Overview Summary	2
4. State Specific Terms and Conditions.....	3

1. Member Agency (State) Terms and Conditions

A single IFB is being published and distributed on behalf of the Member Agencies in many states. Differences in contract implementation and operation will exist between the Member Agencies. Each state may have special laws relating to this procurement that must be adhered to in addition to the previously stated constraints. *When Member Agency/State Specific Terms and Conditions differ from the General Terms and Conditions, the Member Agency/State Specific Terms and Conditions will prevail.*

2. Common Terms and Conditions

Active Promotion of Contract: Agencies require that the Vendor Partner take ownership and actively promote the contract in cooperation with the AEPA Member Agency to all of the Agencies’ qualified Participating Entities.

Sales to Participating Entities: AEPA Member Agencies require that all awarded Vendor Partners offer the Member Agency contract opportunity to all qualified Participating Entities of the cooperative.

Legal Obligations: All Vendor Partners shall comply with all applicable Federal, State and Local Laws, Codes and Regulations while fulfilling the contract. It is the Bidder’s responsibility to be aware of and comply with all state and local laws governing this procurement. Applicable laws, codes, and regulations (etc.) must be followed even if not specifically identified herein.

Administrative Fees: AEPA Member Agencies charge Vendor Partners an administrative fee (a percentage of sales in their respective state or states that they extend the AEPA pricing to). Administrative Fees are generally paid to each Member Agency on a quarterly basis. Additional details of how these fees are charged may be found under each state’s Terms and Conditions.

A summary of each State’s Administrative Fee, any special terms and conditions, and special ordering process requirements is listed here for the convenience of the Bidders.

3. Member Agency General Overview Summary

AEPA Member Agency State	General			Ordering Process			Construction Products & Services								Potential Customers								
	Administrative Fee	Bid Securities Required on Bid Due Date	Special Reporting Requirements	Standard Ordering Process	Electronic Ordering	Online Marketplace	Special Ordering Process	Davis Bacon & State Wage Rates	Performance Bonds Required	Contractor's Licensing Required	Permits and/or Registration Required	Construction Project Cost Limitations	Participate in Construction Services	Participate in Construction Products Only	Products are Taxable	Service is Taxable	K-12 Education	Higher Education	Private Schools	Nnprofits	Federal Agencies	State Agencies	Cities & Counties
California	2%	N	N	Y	Y		N	N	N	N	Y	N	Y	Y	N	Y	Y	Y	Y	Y	Y	Y	Y
Colorado	2%	N	N	Y	N		N	N	N	N	N	Y	Y	N	N	Y	Y	Y	Y	Y	Y	n	Y
Connecticut	2%	N	N	Y	Y	Y	N	Y	N	Y	Y	N	Y	N	N	Y	Y	Y	Y	Y	Y	N	Y
Florida	2%	N	N	Y	Y	Y	N	Y	N	Y	Y	N	Y	Y	N	N	Y	Y	Y	Y	Y	Y	Y
Georgia	2%	Y	Y	Y	Y	Y	N	N	Y	Y	Y	Y	Y	Y	N	N	Y	Y	Y	N	N	N	N
Illinois	2%	N	Y	Y	Y	N	N	Y	Y	Y	Y	Y	N	Y	N	N	Y	Y	Y	N	N	Y	Y
Indiana	Var.	N	Y	Y	Y		N	-	-	-	-	-	-	-	-	Y	Y	Y	Y	Y	Y	Y	Y
Iowa	2%	Y	Y	Y	Y	Y	N	N	Y	N	N	Y	N	Y	N	N	Y	Y	Y	Y	Y	Y	Y
Kansas	2%	N	N	Y	Y	Y	Y	Y	Y	Y	Y	N	Y	N	N	Y	Y	Y	Y	Y	Y	Y	Y
Kentucky	2%	N	N	Y	Y	Y	N	Y	Y	Y	Y	Y	Y	Y	Y	N	Y	Y	Y	Y	Y	Y	Y
Massachusetts	2%	N	N	Y	Y	N	N	-	-	-	-	-	-	-	-	Y	Y	Y	Y	Y	Y	Y	Y
Michigan	2%	Y	N	Y	Y	N	N	Y	Y	Y	Y	Y	Y	Y	N	N	Y	Y	Y	Y	Y	Y	Y
Minnesota	2%	N	Y	Y	Y	Y	N	Y	Y	Y	Y	Y	Y	Y	N	N	Y	Y	Y	Y	Y	Y	Y
Missouri	2%	N	Y	Y	Y	Y	N	Y	N	N	Y	N	Y	N	N	Y	Y	Y	Y	Y	Y	Y	Y
Montana	2%	Y	N	Y	Y		Y	Y	Y	Y	Y	N	Y	Y	N	N	Y	Y	Y	Y	Y	Y	Y
Nebraska	2%	N	N	Y	Y	Y	N	Y	Y	Y	Y	Y	N	Y	N	Y	Y	Y	N	Y	Y	Y	Y
New Jersey	2%	N	N	Y	Y	N	N	Y	Y	Y	Y	Y	N	Y	N	N	Y	Y	Y	Y	N	N	Y
New Mexico	2%	Y	Y	Y	Y	Y	Y	Y	Y	Y	Y	N	Y	Y	Y	Y	Y	Y	Y	Y	Y	N	Y
North Dakota	2%	Y	Y	Y	Y	Y	N	N	Y	Y	Y	Y	Y	Y	N	N	Y	Y	Y	Y	Y	Y	Y
Ohio	2%	Y	Y	Y	Y		N	Y	Y	Y	Y	N	Y	Y	N	N	Y	Y	Y	Y	Y	Y	Y
Oregon	2%	N	Y	Y	N	N	Y	Y	Y	Y	Y	Y	Y	Y	N	N	Y	Y	Y	Y	Y	Y	Y
Pennsylvania	2%	N	Y	Y	Y		Y	Y	Y	Y	Y	N	Y	N	N	Y	Y	Y	Y	Y	Y	Y	Y
Texas	2%, 1% JOC	N	Y	Y	Y	N	Y	Y	Y	Y	Y	Y	Y	Y	N	N	Y	Y	Y	Y	Y	Y	Y
Virginia	2%	N	N	Y	Y		Y	N	N	Y	Y	Y	Y	Y	N	N	Y	Y	Y	Y	Y	Y	Y
Washington	2%	N	Y	Y	Y		Y	Y	Y	Y	Y	N	Y	Y	Y	Y	Y	N	N	Y	Y	Y	Y
West Virginia	2%	Y	N	Y	Y	N	N	Y	Y	Y	Y	Y	Y	Y	Y	Y	Y	Y	Y	Y	Y	Y	Y
Wisconsin	2%	N	N	Y	Y		N	Y	Y	N	Y	Y	Y	Y	N	Y	Y	Y	Y	Y	Y	Y	Y
Wyoming	2%	Y	Y	Y	Y	Y	N	Y	Y	Y	Y	Y	Y	N	N	N	Y	Y	Y	Y	Y	Y	Y

4. State Specific Terms and Conditions

1. California, Monterey County Office of Education dba CalSave

1) Governing Law and Venue

The laws of the State of California govern the Contract and prevail in the interpretation and administration of the Contract. California-specific Terms and Conditions prevail over any General Terms and Conditions. Each and every provision of law and clause required by law to be included in the Contract shall be deemed to be inserted herein, and the Contract shall be read and enforced as though it were included. If through mistake or otherwise any such provision is not included, or is not currently included, then upon application of either party the Contract shall be physically amended to make such inclusion or correction.

The venue for any litigation arising out of or related to the Contract shall be with either the Superior Court in and for the County of Monterey, State of California or the Federal District Court for the Northern District of California, San Jose Division.

2) Authority

For California, this bid is issued under the authority of the elected Monterey County Superintendent of Schools, who administers the Monterey County Office of Education (MCOE), located at 901 Blanco Circle, Salinas California, 93912. In this document, MCOE may be referred to as Agency, being distinct from other parties who may use this contract who are hereinafter referred to as Local Education Agencies (LEAs), regardless of their hierarchy or their political and organizational status as schools or municipalities.

3) CalSAVE, Administration, and Agent

Contracts awarded and Awarded Contractors/Vendors will automatically be part of the CalSAVE program, and by bidding a vendor must agree to participate. CalSAVE is the cooperative purchasing program founded by the Monterey County Office of Education and administered by the Epylon Corporation under a contract with MCOE, in cooperation with the California County Superintendents Educational Services Association (CCSESA). MCOE is the lead agency for all Contracts, and the Monterey County Superintendent of Schools is the authority for the solicitation, evaluation and award of all contracts. Epylon serves as MCOE's agent, but only the Monterey County Superintendent of Schools has the authority to award contracts. Correspondence and communication related to the contract award or administration of the program should be directed to Epylon, 630 San Ramon Valley Blvd., Suite 210, Danville, CA 94526.

MCOE reserves the right to change agents or to change the contact name of existing Agent's personnel administering the contract. If Agent or Agent's personnel change, Awarded Contractors/Vendors will be notified with new instructions.

4) Transaction Fees

Transaction Fees are the funding source for the operation of the self-supporting CalSAVE cooperative purchasing program. Awarded Contractors/Vendors shall be required to pay a Transaction Fee for all purchases by LEAs made through the awarded Contract. For the purpose of this bid through Monterey County Office of Education and all Contracts awarded using this document, the Transaction Fee shall be 2 percent of Net Sales, which means gross sales less returns and cancelled orders within 30 days, shipping and sales and other taxes (excluding taxes based on net income). Transaction Fees will not be charged to or paid by the buyers themselves. Neither Awarded Contractor/Vendor nor its designated authorized reseller(s) shall include any additional amount corresponding to the Transaction Fees in the awarded Contract prices. This Transaction Fee applies to all orders, regardless of the method used to submit the order, or the quantity or dollar amount of the order.

Epylon will collect the full Transaction Fee on behalf of the CalSAVE program, unless otherwise advised by Epylon. The Contractor/Vendor will make all participation fee payments within two weeks after sending the quarterly report. Checks are to be made payable to the Epylon Corporation and sent to 630 San Ramon Valley Blvd., Suite 210, Danville, CA 94526.

5) Non-Conforming Jurisdictions

Notwithstanding Section A.4 (immediately above) no Transaction Fee is authorized to be charged to Awarded Contractors/Vendors for sales within any jurisdiction where prohibited by law or local- government policy. Instead, the cost of products, services, licenses and goods sold under this contract in such jurisdictions shall be the same as for all school districts in all other counties of California. However, any LEA using this contract where Section 4 fees are not permitted shall be required to pay a 2 percent fee for use of the contract, imposed by MCOE on the authority of Public Contract Code Section 20118 and 20652, which allows MCOE to charge reasonable costs to the public corporation or agency for furnishing the services incidental to the purchase of items under contract.

6) Reports

The Contractor/Vendor will compile a quarterly report listing each purchase made by participating Agencies under this contract, and send them by the 15th of April, July, October, and January to Racquel Landolf with the e-mail address of

rlandolf@epylon.com. These reports shall be in Microsoft Excel format and shall have file names that identify the contractor/vendor and the month being reported. The file at a minimum shall include the fields listed below and shall allow for sorting on any of these fields:

- Date of Order
- Name of Participating Agency (LEA)
- Description of Item Purchased
- Manufacturer's SKUNumber
- Quantity
- Contract Unit Price
- Extended Price
- List Price Before AEPA Discount

7) Length of Term

The term of the agreement shall commence on the date of the award and continue as stipulated in General Terms and Conditions, unless terminated, canceled or extended. Contract may be terminated by MCOE if LEAs have not used the contract in any 12-month period, or if orders from participating LEAs do not total \$10,000 in any 12-month period. California statutory term limits and extensions shall apply.

8) Marketing and Advertising under this Agreement

Vendor will actively promote the use of this contract by LEAs in California. Vendor must comply with the marketing plan offered as part of its bid submission. Unless other arrangements are made with the CalSAVE administrator, vendor is also required to perform the following:

- a. Vendor will include the approved CalSAVE logo, web address, and toll free number in all print electronic mail and other advertising and promotion intended for release to California K-12 schools, excluding national marketing releases.
- b. The CalSAVE logo and associated CalSAVE information shall be of a clearly readable size and in appropriate proportion to other elements in the printed material.
- c. Vendor agrees to provide CalSAVE with a copy or proof sheet of the advertisement or promotion material. Vendor will provide CalSAVE with date of release and name of publication, journal, etc.
- d. Vendor shall place a supplied CalSAVE vendor sign on booths, tables, etc. of any or all exhibits for which the vendor displays/participates at California tradeshows, conventions and the like. Vendor will supply in advance scheduled exhibit dates. Vendor agrees to make available at the exhibit CalSAVE supplied brochures or other promotion materials.
- e. Vendor agrees to insert the approved CalSAVE logo, web address, and toll free number on the vendor's web site promoting or a specific CalSAVE landing page and providing a link to the CalSAVE website.
- f. Vendor will supply product catalog information, product description, pricing, etc., in a spreadsheet format as specified by CalSAVE for inclusion on the CalSAVE website.
- g. Vendor agrees to cooperate in developing appropriate website content to promote its products, services and their advantages to school districts.
- h. Requested materials will be submitted to CalSAVE within 30 days.

A. Additional Member Agency Terms and Conditions for Non-Construction Products and Services

1) Conformance to Public Contract Code 20111

An award by the Monterey County Superintendent of Schools under this solicitation will be for the purchase of equipment, materials, supplies, services or repairs to be furnished, sold, or leased in accordance with Public Contract Code 20111 and 20650. Awards shall include allowance for installation and assembly services incidental and necessary to the use of the equipment, materials, supplies and repairs purchased or leased.

2) Conformance to Public Contract Code 20118 and 20652

All public agencies (LEAs) are authorized by law to purchase off a contract awarded by an agency that has itself gone to bid, including all K-12 schools districts, community college districts, special districts and JPAs serving education, pursuant to Public Contract Code Sections 20118 and 20652. Using these statutes, the Monterey County Office of Education hereby declares its intent and authorization to make all contracts awarded under this contract "piggybackable" by other agencies in the state. The Agency waives any right to receive payment from other California agencies making purchases off the awarded contracts and those agencies will make payment directly to the vendors. Any legislative changes to Public Contract Codes 20118 and 20652 during the term of the contract(s) with Award Vendor(s) shall apply to the contract(s) immediately when such changes become law.

3) Additional Piggyback and Standard School Supply and Equipment Authority

The Monterey County Office of Education declares that items, materials, personal property, equipment and licenses under Contract as a result of this Invitation to Bid will qualify as items to be included within its Standard School Supply and Equipment List. Because many County Offices of Education have banded together to create both the EdBuy and the CalSAVE programs for the purpose of collectively creating both a standard School Supply & Equipment List and cooperative contracts, the items solicited and awarded through this bid may also constitute a portion of an official Standard School Supply and Equipment List for other participating County Offices of Education and County Superintendents of Schools. Purchases by other County Offices of Education and LEAs may be made, not only in accordance with Public Contract Code 20118 and 20652, but also in accordance with Education Code 38110 and 38112 dealing with cooperatives and Standard School Supplies & Equipment.

B. Additional Member Agency Terms and Conditions for Construction Products and Services

1) Intended for Personal Property

An award by the Monterey County Superintendent of Schools under this solicitation will be for the purchase of equipment, materials, supplies, services or repairs to be furnished, sold, or leased in accordance with Public Contract Code 20111 and 20650. Awards shall include allowance for installation and assembly services incidental and necessary for use of the equipment, materials, supplies and repairs purchased or leased. When any services or repairs fall into a category of Public Works as defined in Public Contract Code 22002, an LEA may use this California contract only up to \$14,999 for labor and services, but for an unlimited dollar amount for any supplies, materials, equipment or personal property to be staged and ready for use in a local Public Works project.

2) Public Works Limitations

When Public Works services cost \$15,000 or more, an LEA, under most situations, must bid itself independently for the services and labor related to the public work, but may use this contract for the contracted supplies, material or equipment related to the project. If circumstances allow, LEAs may also combine this competitively bid contract with other alternative authorities for Public Works projects as may be allowed by law, such as Public Contract Code 22030, Education Code 17406 or Government Code 1466. LEAs should consult with their own legal counsel to see if such statutes apply to their Public Works projects.

C. Procedure for Processing Orders

1) Start date

Once the award is made to the Contractor/Vendor and signatures have been placed on the contract from both parties, the Awarded Contractor/Vendor is authorized to begin selling to eligible Agencies. MCOE will begin informing LEAs of the Contract once the Contract has been signed.

2) Prices and Requests for Quotes

The Awarded Contractor/Vendor, in cooperation with MCOE's agent, must make provision for LEAs to quickly ascertain bid prices by posting prices, posting a link or contact for prices, distributing catalogs and price lists, responding to requests for quotations, or participating in eCommerce.

The 2 percent Transaction Fee on all sales is a cost of doing business to the vendor and the requirement for the fee is publicly disclosed in these bid documents for the edification of all buying agencies and LEAs. Transaction fees should not appear as a line item on a quotation or on listed bid pricing. The final price quoted or displayed must be inclusive of the participation fee on all pricing and quotations.

3) Submission of Orders and Delivery

After entering into an agreement with MCOE, an LEA electing to use this Contract will enter into a separate contract with the Vendor by way of a purchase order or separate contracting document ("Separate Contract"). Purchase orders will be issued by participating LEAs to contractor/vendor.

LEAs will fax or mail purchase orders directly to the CalSAVE office fax at (866) 488-3729), unless other arrangements have been made and agreed to by the CalSAVE Administrator. LEAs may also use Epylon eCommerce software for transmission of purchase orders. Standard business practice is for all purchase orders received by 3:00 p.m. Pacific Time to be logged and forwarded to the appropriate vendor on the same day received, unless unusual circumstances occur. It is the responsibility of the awarded/Vendor contractor to track any purchase order received directly from an LEA and to include that order on quarterly reports.

Awarded Contractor/Vendor will deliver goods, services and corresponding invoices directly to the participating LEAs and receive payments directly from the participating LEAs as per bid specifications.

D. Agencies Allowed to Purchase under the Member Agency

1) Other Agencies' Right to Purchase.

CalSAVE is a self-supporting contracting program led by the Monterey County Office of Education. Contracts are made available to all California public school districts, private and non-public schools registered with a county office of education or state Department of Education, charter schools, community college districts, eligible state agencies, non-profits (particularly those such as PTAs buying on behalf of schools or government), and any other agency allowed by law – all referred to as LEAs.

Subject to the following terms and conditions, the Monterey County Office of Education (MCOE) consents to LEAs purchasing items at the same unit price(s) or pricing formula under the terms and conditions of this Contract, as may be authorized by Sections 20118 and 20652 of the Public Contract Code or other legal authority:

a) Any other agency (LEA) authorized by law to use this Contract for its own purchase(s) from the Awarded Contractor/Vendor or their authorized resellers shall by default enter into a standard agreement with MCOE, which *inter alia* will include the terms, conditions, and information set forth in this paragraph *a* and paragraphs *b* through *i* below.

After entering into a standard agreement with MCOE, an Other Agency electing to use this Contract will enter into a separate contract or purchase order ("Separate Contract") with the contractor/vendor. The Separate Contract is subject to and includes and/or incorporates all applicable terms of this Contract and the specific requirement that the Awarded Contractor/Vendor comply with the provisions set forth in the paragraph regarding payment of the 2 percent Transaction Fee (or the non-conforming jurisdiction fee) to be collected by the Epsilon Corporation. MCOE will not be a party to any Separate Contract, but will be considered a third party beneficiary of such Separate Contract.

- a) The Awarded Contractor/Vendor understands and agrees that failure or refusal to comply with the provisions set forth in this agreement regarding payment of the 2 percent Transaction Fee in conjunction with any Separate Contract or any other use of this Contract by an "Other Agency" is grounds for cancellation of the Contract. The Contractor/Vendor also understands and agrees that if the Contract is cancelled for this or any other reason, MCOE may give notice of such cancellation by any other means appropriate to inform LEAs of that cancellation.
- b) The MCOE waives any right it may have to require any LEA using this Contract to draw its warrants for the purchase(s) in its favor and consents to each agency making such payment(s) directly to the contractor/vendor.
- c) Sales tax and freight/shipping charges included in the Contract apply to the MCOE only. Additional sales tax and freight/shipping charges may be required on purchases by any LEA and are outside the scope of this Contract, unless specifically addressed elsewhere in Part A or Part B of the Terms and Conditions.
- d) This Contract and any Separate Contract are for the purchase of the items covered by Contract. An LEA may, however, exercise its authority under Education Code section 17597 or 81645 or other legal authority to sell and lease back any item owned by, or to be owned by, it pursuant to any Separate Contract. The contractor/vendor agrees to take any and all actions requested by any LEA that are necessary to effect any such transfer, by way of example only, accepting payment under the Separate Contract from any third party to whom any such transfer is made.
- e) Both the contractor/vendor and any LEA using this Contract agree that the MCOE makes no representation that use of this Contract by any Other Agency is, in fact, authorized by law. In this regard, the MCOE suggests that, at a minimum, Contractor/Vendor and any LEA considering such use consult with their own legal counsels before doing so.
- f) Both the contractor/vendor and any LEA using this Contract agree to defend, indemnify and hold the MCOE, the Monterey County Superintendent of Schools, and the Monterey County Board of Education and its members, as well as all of their respective officers, employees and agents, free and harmless from any claims, liabilities, costs, penalties, or interest arising out of any such use.
- g) MCOE reserves the right to cancel the whole or any part of this contract due to failure by the contractor to carry out any obligation, term or condition of the contract. MCOE will issue written notice to the contractor for acting or failing to act in any of the following:
 - a. The vendor fails to adequately perform the services set forth in the contract
 - b. The vendor fails to make progress in the performance of the contract and/or gives MCOE reason to believe that the contractor will not or cannot perform to the requirements of the contract
 - c. The contractor fails to observe any of the terms and conditions of the contract

d. The contract fails to pay Transaction Fees

e. The contractor fails to follow the established procedure for purchase orders, invoices and receipt of funds as stipulated by the MCOE. MCOE shall follow the following procedure if the contract is to be terminated:

- Step 1 - Issue a warning letter of concern outlining the violations and length of time to correct the problem(s).
- Step 2 - Issue a letter of intent to cancel the contract, if the problem(s) is not resolved by a given date.
- Step 3 - Issue letter to cancel the contract. Upon receipt of the written notice of concern, the contractor shall have ten (10) business days to provide a satisfactory response to MCOE.

Failure on the part of the contractor to address adequately all issues of concern may result in contract cancellation.

2) Other Agencies, Constitutionally Independent Agencies, and Out-of-State Agencies

Other agencies and out-of-state agencies and LEAs may use the contract as allowed by California Government Code Section 6502, which says, "If authorized by their legislative or other governing bodies, two or more public agencies by agreement may jointly exercise any power common to the contracting parties, even though one or more of the contracting agencies may be located outside this state. It shall not be necessary that any power common to the contracting parties be exercisable by each such contracting party with respect to the geographical area in which such power is to be jointly exercised. For purposes of this section, two or more public agencies having the power to conduct agricultural, livestock, industrial, cultural, or other fairs or exhibitions shall be deemed to have common power with respect to any such fair or exhibition conducted by any one or more of such public agencies or by an entity created pursuant to a joint powers agreement entered i

2. Colorado - Colorado BOCES Association (CBA)

A. *Additional Agency Terms and Conditions*

Advertising: CBA will require a marketing flier, in electronic format, and timely updates from each vendor promoting the contract and AEPA/CBA relationship. CBA will assist in the development of the marketing flier and other appropriate materials which will include logos representing the vendor/AEPA/CBA. This flier will be for distribution and dissemination to all qualified customers through the CBA website and other appropriate and available methods.

Sales to Qualified Customers: Boards of Cooperative Educational Services (BOCES) in Colorado are legislatively created cooperative organizations directed by Colorado state statute 22-105 to serve all qualified agencies in a cooperative manner. BOCES are governed by publicly elected officials and by state and federal laws. No agency is obligated to use these services and contracts, but they find the benefits of low price and the satisfied bidding process most advantageous. Qualified agencies in Colorado include all public or private educational institutions, K-12 and higher education, all non-profit organizations, and all county or local governmental agencies. CBA requires that all participating vendors offer the Agency contract opportunities to all qualified customers.

B. *Procedure for Processing Orders:* Once the award is made to the vendor.

- CBA will inform its members of the contract by:
 - i.* Including the contract in the agency database that is available on the CBA website
 - ii.* Announcing the award through normal communication channels, CBA member presentations as well as regular electronic and direct mail communications.
 - iii.* Offering the opportunity to the vendor to publish their marketing information on the CBA website link to cooperative purchasing opportunities.
- A listing of CBA members, institutional names, contact names, addresses and phone numbers is available to the vendors through the CBA website. At this point the vendor must contact the members and qualified customers; and the customers have the right to contact the vendors directly. Note: CBA requires the awarded vendors to take ownership and actively promote the contract in cooperation with CBA to all members and qualified customers.
- When the customer identifies a desired product or service as available through the AEPA/CBA contract and agrees on price as presented to the customer by the awarded AEPA/CBA vendor, the customer then issues to the vendor a purchase order for that item or service.
- The awarded price must include an additional two percent (2%) administrative fee in the total cost (not as a separate line item), based on the total cost of goods and services including installation. This fee is to be forwarded by the vendor to CBA after the sale and payment is made to the vendor. Payment shall be made to CBA on a quarterly basis along with the complete sale report as specified in the general terms and conditions.
- The sale and transaction may continue without delay or anticipation of the CBA denial of said transaction.
- The administrative fee percentage (2%) is based on the total sale of goods and services including installation and must be included in the original cost quoted to the customer. In the event of a lease, the total administrative fee for the value of goods and services shall be paid to CBA by the vendor at the front end of the lease.
- Vendor makes all deliveries and installation of products and services. CBA does not warehouse items nor provide services.

3. Connecticut, Capitol Region Education Council (CREC)

A. ADDITIONAL MEMBER AGENCY GENERAL TERMS AND CONDITIONS

Affirmative Action - The Contractor must have an employment policy that there shall be no discrimination against anyone on the grounds of race, color, religious creed, age, marital status, national origin, ancestry, sex, mental retardation, physical disability or sexual orientation in the hiring, upgrading, demotions, recruitment, termination and selections for training, in any manner prohibited by the laws of the United States or of the State of Connecticut. The Contractor further agrees to be an "affirmative action-equal opportunity employer."

Applicability of Contract Provisions to Connecticut Participants - The Capitol Region Education Council (CREC) is the AEPA Member Agency. Any entity that uses the contract awarded by CREC under this document is referred to as a "Participant." The bidder that is awarded the contract by CREC is referred to as the "Contractor."

Conflict of Interest

The Contractor shall disclose any relationship with a CREC employee that would not be considered an "arms-length" or independent transaction, as described below. This disclosure must be made in writing to CREC for an evaluation. CREC will respond to this disclosure in writing.

A CREC employee (including independent contractors for purposes of this definition) placing an order or recommending a vendor must disclose any relationship with that vendor which would not be considered an "arms-length" or independent transaction. This disclosure must be made in writing to CREC for an evaluation. CREC will respond to this disclosure in writing.

For a transaction to be considered "arms-length" or "independent", a CREC employee should not be influenced, dependent upon, guided or controlled by a vendor into choosing that vendor, or item to purchase; nor should it appear to a third party that a CREC employee made a purchasing decision which appears to be based upon a personal relationship between the CREC employee and vendor.

The following are examples when a transaction is NOT considered arms-length or independent: (1) when there exists a personal relationship between a CREC employee and a vendor, (2) when there exists the potential for a personal benefit to a CREC employee, or (3) the parties to a business deal are dependent upon one another for "something" other than the purchase itself.

In addition, the Contractor shall, if given a copy of the potential Participant's conflict of interest policy, follow the process in that policy, or otherwise disclose to a potential Participant any relationship that would not be considered an "arms-length" or independent transaction with that Participant, as described above. This disclosure must be made in writing to the chief official (for example, the Superintendent at a board of education) at the potential Participant.

Determination of the existence of a conflict of interest does not prohibit CREC and/or a Participant from entering into the contract and purchase order, respectively.

Financing Arrangements - Any financing arrangements (including lease purchasing arrangements) will be made directly between the Contractor and a Participant. Financing arrangements may be subject to additional laws, rules and regulations, terms and conditions not described in this document and are subject to separate negotiation with each Participant that is interested in such an arrangement. Each Participant should seek its own legal advice prior to entering into a financing arrangement. CREC must receive a report annually summarizing the executed lease purchases along with the summary of the customer purchases. CREC will not collect lease payments or be involved

in the terms and conditions of the lease. All lease arrangements are between the Contractor and the Participant only.

Freedom of Information Act - The Contractor acknowledges that CREC and some Participants are subject to the Freedom of Information Act, Connecticut General Statutes Sections 1-200 et seq., and submitted to CREC and/or such Participants may be made available to the public under the provisions of the Freedom of Information Act.

Incorporation of Bid Documents - The bid documents, including all appendices executed by Contractor that have been accepted by CREC (the "Bid") are specifically incorporated into this Contract.

Independent Contractor - The Contractor shall not be held or deemed in any way to be the agent or employee of CREC and/or a Participant. It is the intention of the parties that the Contractor shall be and is to be considered an independent contractor.

Marketing and Advertising - Contractor agrees to provide CREC with a copy or proof sheet of all advertisements, customer communications or promotional material for prior approval.

Modification to Bid Language in the AEPA Invitation for Bid - The Bidder by submitting its bid hereby declares that this Bid is made without any connection with any other person or persons making any proposal for the same items, that it is in all respects fair and without collusion or fraud and that no person acting for or employed by CREC or a Participant is directly or indirectly interested in the proposal or in the goods or services to which it relates, or in any portion of the profits therefrom.

5. ADDITIONAL MEMBER AGENCY TERMS AND CONDITIONS FOR NON-CONSTRUCTION PRODUCTS AND SERVICES

None

6. ADDITIONAL MEMBER AGENCY TERMS AND CONDITIONS FOR CONSTRUCTION PRODUCTS AND SERVICES

CT Commission on Human Rights and Opportunities

Municipal Public Works contracts funded in whole or in part by the State of Connecticut are subject to contract compliance requirements and set-aside goals as follows:

The contractor who is selected to perform this State project must comply with CONN. GEN. STAT. §§ 4a-60, 4a-60a, 4a-60g, and 46a-68b through 46a-68f, inclusive, as amended by June 2015 Special Session Public Act 15-5.

State law requires a minimum of twenty-five (25%) percent of the state-funded portion of the contract for award to subcontractors holding current certification from the Connecticut Department of Administrative Services ("DAS") under the provisions of CONN. GEN. STAT. § 4a-60g. (25% of the work with DAS certified Small and Minority owned businesses and 25% of that work with DAS certified Minority, Women and/or Disabled owned businesses.) The contractor must demonstrate good faith effort to meet the 25% set-aside goals.

For municipal public works contracts and quasi-public agency projects, the contractor must file a written or electronic non-discrimination certification with the Commission on Human Rights and Opportunities. Forms can be found at:

http://www.ct.gov/opm/cwp/view.asp?a=2982&q=390928&opmNav_GID=1806

7. PROCEDURES FOR PROCESSING ORDERS

1. Purchase orders will not be accepted or processed by CREC. All business will be contracted directly with the Participant, which will issue a purchase order and provide payment for the applicable good or service directly to the Contractor.
2. To the extent not otherwise described in this document, once a purchase order is issued by a Participant to a Contractor, all of the provisions of the contract shall benefit and be enforceable by such Participant, unless specifically identified as applying to CREC only.

8. AGENCIES ALLOWED TO PURCHASE UNDER THE MEMBER AGENCY

There are 169 school districts in Connecticut and all are eligible for membership. No district is obligated to use these services. Additional members may include other public educational institutions, public colleges or universities, community colleges, vocational or technical schools, municipal governments, and other governmental, quasi-governmental, or non-profit organizations.

Work in Other States

CREC is making the CT AEPA contract available for vendors to use in all New England states – CT, ME, NH, RI, VT – and New York, and any other state without AEPA member representation. Our contract is also available in MA for vendors who TEC has been unable to sign with.

Sales made in any of these states using the AEPA contract are to be reported to CREC, with the 2.0% administrative fee made payable to CREC. The Contractor must advise CREC its intent to use the contract in any of these states.

All Terms and Conditions for Connecticut apply to work in these states. It is the Contractor's obligation to ensure that the purchaser fully understands the AEPA contract, including whether it is allowable under applicable state regulations.

4. Florida, Panhandle Area Education Consortium Florida Buy

A. Additional Agency Terms and Conditions

Vendor Contact: Vendor will designate to the Panhandle Area Educational Consortium Florida Buy, one individual who will represent them during the agreement period. This contact person will correspond with each ordering member for technical assistance, problems, or questions that may arise, including instructions if different contacts for different geographical areas are needed. This information will be distributed to all school districts upon award of this bid. Vendors may use this contract to sell products or services in addition to school districts to any government agency, non-profit organizations or institutions.

Vendor agrees to abide by all federal, state and local laws and regulations. It is the responsibility of the Vendor to determine applicability and requirements of any such laws and to abide by them.

All terms and conditions may be modified and revised by PAEC Florida Buy with the written consent of both PAEC Florida Buy and the Awardee.

PAEC Florida Buy, at its discretion, may offer the use of the awarded agreement to governmental entities such as state agency purchasing programs, to extend the use of the contract to eligible users. This option will be referred to as an Interlocal Agreement. Under such conditions, the participating agency may, with written consent from the Awardee, modify and revise the terms and conditions of the master agreement.

Other state and public agency purchasing program agreements may require additional administrative fees, associated with sales, to be paid by the Awardee for the management of the contract. The Awardee will be notified in writing and will have the option of accepting or rejecting the Interlocal Agreement program fees.

No right or interest in the Contract shall be assigned or transferred by the Contractor without the prior written consent of the PAEC Florida Buy program. No delegation of any duty of the Contractor shall be assigned without prior written permission of PAEC Florida Buy. If the original Vendor/Contractor sells or transfers all assets or the entire portion of the assets used to perform this Contract, a successor in interest must guarantee to perform all obligations under this Contract. PAEC Florida Buy reserves the right to reject the acquiring person or entity as a Vendor/Contractor. A change of name agreement will not change the contractual obligations of the Vendor/Contractor.

The Awardee, may, upon entering into negotiations with qualified buyers, amend their prices to offer volume discounts below the lowest unit rates established in the pricing portion of this agreement.

B. Procedures For Processing Orders

Once the award is made to the Vendor, PAEC Florida Buy will inform all school districts of the contract by:

1. Including the award information on the PAEC Web site at www.floridabuy.org
2. Announcing the award in its PAEC Florida Buy website
3. Announcing the award via electronic mail to all members

Any members, contact names, addresses and phone numbers will be available at the PAEC Web site www.floridabuy.org. At this point, the Vendor may contact the members and the members may contact the Vendor. The member will identify a desired product or service available through the AEPA contract and agrees on the price and conditions as presented to the member by the awarded AEPA Vendor. The member then issues to the Vendor a purchase order for that item or service. The purchase order must include an additional (2%) administrative fee built into the total invoiced cost, based on the total costs of good, services and installation. A final copy of the customer purchase order or sales summary must be sent to PAEC Florida Buy by the Vendor after completion of the service or installation. The Vendor has (30) thirty days to forward this purchase order. This will insure compliance of the contract.

Vendor makes all deliveries and installations of products and services. PAEC Florida Buy does not warehouse items. All participating Vendors agree to and are subject to audit proceedings of the AEPA sales to members.

The Vendors price will include a (2%) administrative fee that the Vendor shall collect from the member and remit to PAEC Florida Buy on a quarterly basis. The Vendor will produce and provide to PAEC Florida Buy quarterly reports ending March 31, June 30, September 30 and December 31 throughout the contract period. The reports shall identify the Vendor and the quarter being reported, shall include a minimum of the fields listed below:

1. Date of Order
2. School district
3. List or academic price sales totals
4. PAEC Florida Buy price sales totals

5. Member savings total

Quarterly reports and administrative fee payments to PAEC Florida Buy are due the 15th of the succeeding month, and all checks are to be made payable to the Panhandle Area Educational Consortium and sent to: PAEC, 753 West Blvd, Chipley, Florida 32428 and Attention: Florida Buy. PAEC may designate another agent for collecting and administrative fee that will be negotiated with Vendor for e-commerce transactions.

C. Agency Members Purchasing Under The Member Agency

The Panhandle Area Educational Consortium is a fourteen-member consortium that includes a voluntary purchasing program developed for schools in Florida. All other school districts in Florida are participating members in the programs of the Panhandle Area Educational Consortium (PAEC), including participation in the statewide cooperative purchasing program. Agencies that use this contract will be in compliance with FS1001.42. PAEC was established to provide easily accessible information for our member and participating public school districts and the communities we serve. Since the creation of PAEC in 1967, our school districts have benefitted from shared services made available through leading edge technology. While school districts access our teaching and learning, training and technology, and business operations services in varying degrees of need, all come for the mutually beneficial purpose of reaching their goals together.

5. Georgia, Cooperative Purchasing Agency (CPA)

1. General Overview

- a. Cooperative Purchasing Agency is now the AEPA representative for the state of Georgia. In Georgia we advertise our bids on the state procurement registry website:
<http://doas.ga.gov/state-purchasing/georgia-procurement-registry-for-local-governments>
- b. In 1971 several small school systems in North Georgia decided to work together & form **Cooperative Purchasing Agency (CPA)**, a non-profit organization built by & for the school systems to combine their purchasing power. As a division of North Georgia, Northeast Georgia, & Pioneer RESA; Pioneer RESA serves as our fiscal agent and as such we currently show up on the Georgia Procurement Registry as Pioneer RESA. CPA serves as a purchasing agent for classroom & office supplies for its 35-member school systems plus neighboring ones who choose to take advantage of cooperative buying. CPA also serves as a recipient agency for USDA commodities that member systems receive through the USDA school lunch program. In addition to items included in our catalog & website, CPA has access to brands, custom items, & entire product categories that meet systems' office & classroom needs – including furniture options (indoor & outdoor), playground equipment, shelving installations, print supplies, & more.

2. Additional Participating Agency Terms and Conditions for Construction Related Products and Services

- a. Georgia requires all local school boards to post any bids requiring capital improvements / public works construction over \$100,000.00 to be posted on the Georgia procurement website, regardless of who they are purchasing through.

3. Local Government Provisions - Provisions Applicable to Counties, Municipal Corporations, And Other Governmental Entities

- a. § 36-91-20. Written contract required; advertising; competitive sealed bidding; timing of addendums; prequalification
 - i. All public works construction contracts subject to this chapter entered into by a governmental entity with private persons or entities shall be in writing and on file and available for public inspection at a place designated by such governmental entity. Municipalities and consolidated governments shall execute and enter into contracts in the manner provided in applicable local legislation or by ordinance.
 - ii. Prior to entering into a public works construction contract other than those exempted by Code Section 36-91-22, a governmental entity shall publicly advertise the contract opportunity. Such notice shall be posted conspicuously in the governing authority's office and shall be advertised in the legal organ of the county or by electronic means on an Internet website of the governmental entity or an Internet website identified by the governmental entity which may include the Georgia Procurement Registry as provided by Code Section 50-5-69.
 1. Contract opportunities that are advertised in the legal organ shall be advertised a minimum of two times, with the first advertisement occurring at least four weeks prior to the opening of the sealed bids or proposals. The second advertisement shall follow no earlier than two weeks from the first advertisement.
 2. Contract opportunities that are advertised solely on the Internet shall be posted continuously for at least four weeks prior to the opening of sealed bids or proposals. Inadvertent or unintentional loss of Internet service during the advertisement period shall not require the contract award or bid or proposal opening to be delayed.
 3. Contract opportunities that will be awarded by competitive sealed bids shall have plans and specifications available on the first day of the advertisement and shall be open to inspection by the public. The plans and specifications shall indicate if the project will be awarded by base bid or base bid plus selected alternates and:
 - a. A statement listing whether all anticipated federal, state, or local permits required for the project have been obtained or an indication of the status of the application for each such permit including when it is expected to be obtained; and

- b. A statement listing whether all anticipated rights of way and easements required for the project have been obtained or an indication of the status as to when each such rights of way or easements are expected to be obtained.
 4. Contract opportunities that will be awarded by competitive sealed proposals shall be publicly advertised with a request for proposals which request shall include conceptual program information in the request for proposals describing the requested services in a level of detail appropriate to the project delivery method selected for the project.
 5. The advertisement shall include such details and specifications as will enable the public to know the extent and character of the work to be done.
 6. All required notices of advertisement shall also advise of any mandatory prequalification requirements or pre-bid conferences as well as any federal requirements pursuant to subsection (d) of Code Section 36-91-22. Any advertisement which provides notice of a mandatory prebid conference or prequalification shall provide reasonable advance notice of said conference or for the submittal of such prequalification information.
- iii. Governmental entities are authorized to utilize any construction delivery method, provided that all public works construction contracts subject to the requirements of this chapter that:
 1. Place the bidder or offeror at risk for construction; and
 2. Require labor or building materials in the execution of the contract shall be awarded on the basis of competitive sealed bidding or competitive sealed proposals. Governmental entities shall have the authority to reject all bids or proposals or any bid or proposal that is nonresponsive or not responsible and to waive technicalities and informalities.
- iv. No governmental entity shall issue or cause to be issued any addenda modifying plans and specifications within a period of 72 hours prior to the advertised time for the opening bids or proposals, excluding Saturdays, Sundays, and legal holidays. However, if the necessity arises to issue an addendum modifying plans and specifications within the 72 hour period prior to the advertised time for the opening of bids or proposals, excluding Saturdays, Sundays, and legal holidays, then the opening of bids or proposals shall be extended at least 72 hours, excluding Saturdays, Sundays, and legal holidays, from the date of the original bid or proposal opening without need to readvertise as required by subsection (b) of this Code section.
- v. Bid and contract documents may contain provisions authorizing the issuance of change orders, without the necessity of additional requests for bids or proposals, within the scope of the project when appropriate or necessary in the performance of the contract. Change orders may not be used to evade the purposes of this article.
- vi. Any governmental entity may, in its discretion, adopt a process for mandatory prequalification of prospective bidders or offerors; provided, however, that:
 1. Criteria for prequalification must be reasonably related to the project or the quality of work;
 2. Criteria for prequalification must be available to any prospective bidder or offeror requesting such information for each project that requires prequalification;
 3. Any prequalification process must include a method of notifying prospective bidders or offerors of the criteria for or limitations to prequalification; and

Any prequalification process must include a procedure for a disqualified bidder to respond to his or her disqualification to a representative of the governmental entity; provided, however, that such procedure shall not be construed to require the governmental entity to provide a formal appeals procedure. A prequalified bidder or offeror can not be later disqualified without cause. History Code 1981, § 36-91-20, enacted by Ga. L. 2000, p. 498, § 1; Ga. L. 2001, p. 820, § 12; Ga. L. 2007, p. 640, §

6. Indiana, Wilson Education Service Center (WESC)

A. Additional Agency Terms and Conditions

Participating entities and approved vendors must be in full compliance with statutory requirements of all applicable federal, state, and local laws, rules, regulations, and ordinances including applicable public works and prevailing wage projects. All provisions required thereby to be included herein and are hereby incorporated for reference. This contract shall be construed in accordance with and governed by the laws of the State of Indiana. Awarded pricing must be made available to all participating entities regardless of size.

B. Procedure for Processing Orders

Wilson Education Service Center will inform all public school corporations, private/parochial schools, charter schools, nonprofit entities, municipalities, other governmental entities and higher education entities of contract awards via web sites and various marketing strategies. Vendors will have the primary responsibility to market contracts to eligible buyers within Indiana. After contracts are awarded and product information is available on our e-procurement sites vendors are free to contact eligible buyers and vice versa. The Wilson Education Service Center utilizes an e-procurement facilitation system as the primary mechanism for ordering and the primary method of marketing. Vendors are required to use the IAESC Procurement System and GovPro systems upon award. A 2.25% administrative fee will be assessed on gross monthly sales for IAESC Procurement (used by schools) and a 3.25% administrative fee will be assessed on gross monthly sales on GovPro (all other entities) after a 1% price increase. Vendors shall not include shipping and handling charges, federal excise tax, or state sales tax on invoices. Taxes do not apply to purchases by the participating entities. All participating entities have a "Not for Profit Tax Exemption Certificate" which will be furnished by the buyer upon request by the vendor. Quantities shipped in excess of quantities designated in the Purchase Order, or unapproved product substitutions will be returned at the vendor's expense.

C. Members Purchasing Under the Agency

All public school corporations, private/parochial schools, charter schools, nonprofit entities, municipalities, other governmental entities and higher education entities are eligible buyers. The Wilson Education Center as established by Indiana Code 20-1-11.3- 1 with Inter-local Agreement Powers as established by Indiana Code 36-1-7-2 represents all eligible buyers in this program within Indiana.

7. Illinois, Illinois Learning Technology Purchase Program

The following State Specific Terms and Conditions shall apply to all contracts involving public schools and/or other educational entities operating in Illinois, (hereinafter "Illinois Customers") and shall prevail over any General Terms and Conditions if/when they differ.

Illinois Law to Govern.

The Agreement, as modified by these Illinois Terms & Conditions, is (and shall be) governed by, construed under, subject to compliance with, and interpreted in accordance with, the laws and regulations of the State of Illinois, expressly including, (but not limited to): the Illinois School Code, 105 ILCS 5/1-1 *et seq.*; its procurement and bidding standards and prerequisites delineated at 105 ILCS 5/10-20.21; the Illinois Public Officer Prohibited Activities Act, 50 ILCS 105/0.01 *et seq.*; the Illinois Criminal Code, 720 ILCS 5/1-1 *et seq.*; its prohibitions against interference with public contracting delineated at 720 ILCS 5/33E-1, *et seq.*; the Illinois State Officials and Employees Ethics Act, 5 ILCS 430/1 *et seq.*; the Illinois Public Officer Prohibited Activities Act, 50 ILCS 105/1 *et seq.*; the Illinois Drug-Free Workplace Act, 30 ILCS 580/1 *et seq.*; the Illinois Business Enterprises for Minorities, Females and Persons with Disabilities Act, 30 ILCS 575/0.01 *et seq.*; the Illinois Human Rights Act, 775 ILCS 5/2-105 *et seq.*; and policies of the Illinois Customer relating to the subject matter of the Agreement with Contractor.

When Contractor and/or its agents will be on an Illinois Customer's premises (whether for delivery, installation, the provision of contractual services, or otherwise), Contractor shall also comply in all respects with: all background check requirements set forth at 105 ILCS 5/10-21.9; the Illinois Smoke Free Illinois Act, 410 ILCS 82/1 *et seq.*, and the Illinois Firearm Concealed Carry Act, 430 ILCS 66/1 *et seq.*

Any contractual payment requested of an Illinois Customer shall be invoiced, processed, and remitted to a Contractor in accordance with the requirements and provisions of the Illinois Local Government Prompt Payment Act, 50 ILCS 505/1 *et seq.*

This Agreement shall be construed and incorporated in accordance with the laws of the State of Illinois, regardless of any choice of law provision that might otherwise authorize construction of its terms in accordance with the law(s) of another state, states, or federal law.

By entering into this Agreement with an Illinois Customer, the Contractor's signature on the executed contract shall serve as Contractor's certification of Contractor's compliance with the foregoing laws and all requirements thereunder.

Entire Agreement and Construction

The Agreement, as modified by these Illinois Terms & Conditions, represents the entire agreement between Contractor and the Illinois Customer, and supersedes all prior negotiations or agreements, written or oral, which are not included herein. This Agreement may only be amended by written instrument executed by the Illinois Customer and Contractor. In the event of a conflict between the Agreement, as modified by these Illinois Terms & Conditions, and a proposal from Contractor, the terms of this modified Agreement will take precedence.

Each party has reviewed and approved the Agreement, and no rule of construction that resolves ambiguities against the drafting party will be employed in the interpretation of this Agreement.

Dispute Resolution.

Any dispute arising in any manner hereunder shall be subject to resolution by litigation, unless all

involved parties consent to an alternative means of dispute resolution. Venue for any legal action brought hereunder shall be the Illinois state circuit court of the county in which the Illinois Customer's administrative office is located or (if different and only if the Illinois Customer so elects) the Illinois state circuit court of the county where the Project is performed. Any provision of the General Terms purporting to change, limit, restrict, or shorten any Illinois period of repose and/or the duration of any applicable Illinois statute of limitation shall be of no force or effect against an Illinois Customer, it being understood by the parties that the Illinois periods of repose and statutes of limitation applicable to the subject matter hereof shall govern actions relating to this Agreement. No provision from the General Conditions shall limit, restrict, or shorten the duration of any period of repose or statute of limitation applicable under Illinois law.

Termination of the Agreement.

The Illinois Customer may terminate this Agreement at any time, in whole or in part, with or without cause, upon providing written notice to Contractor. If this Agreement is terminated by the Illinois Contractor for cause, the Contractor shall be liable to the Owner for any increase in cost incurred by the Owner in replacing the goods under contract and/or completing the contractual work, and for any additional or other damages the Illinois Customer suffers. In the event this Agreement is terminated by the Illinois Customer solely for the Illinois Customer's convenience, Contractor shall be compensated for items properly provided and/or work properly rendered through the date of termination, as can be documented to the reasonable satisfaction of the Illinois Customer. The Illinois Customer shall have no liability to Contractor beyond the date of termination. In no event shall Contractor be compensated for anticipated profit or lost opportunity.

Insurance and Indemnification Provisions.

Contractor hereby agrees to indemnify and hold the Illinois Customer, its board members, officers, agents, employees, administrators, attorneys, and any other parties designated by the Illinois Customer (hereinafter collectively called the AIndemnitees@) harmless from all losses, claims, liabilities, injuries, damages and expenses, including (but not limited to) all attorneys= fees and defense and court costs and expenses, that the Indemnitees may incur arising out of, or occurring in connection with, the performance, acts, omissions, negligence, willful and/or wanton behavior, and/or breaches by Contractor of its duties and obligations under or pursuant to this Agreement. This indemnification obligation shall not be limited by a limitation on amount or type of damages, compensation or benefits payable by or for the Contractor or a Subcontractor under workers= or workmen=s compensation acts, disability benefit acts or other employee benefit acts.

Contractor shall procure, at no expense to the Illinois Customer, the insurance coverages set forth in the General Conditions. In each such instance, Contractor shall, by endorsement, name the Illinois Customer as an additional insured and shall provide copies of said policies and endorsements to the Illinois Customer prior to commencement under this Agreement.

Funding Contingencies for Multi-Year Projects.

All contracts with Illinois Customers that call for performance, or otherwise extend, beyond the Illinois Customers' current fiscal year, are, and shall be, expressly contingent upon annual appropriations. In the event an Illinois Customer's entry into an Agreement with Contractor constitutes a lease purchase (whether for financing purposes or otherwise), that Agreement shall be subject to the provisions of 105 ILCS 5/10-22.25a in addition to all other terms set forth in this Agreement.

Warranties and Claims.

No provision(s) set forth in the General Conditions shall serve to limit the Contractor's liability with respect to damages of any sort (whether actual, incidental, consequential, or otherwise) suffered by an Illinois Customer, nor will any disclaimer of warranties be effective against an Illinois Customer.

Attorney Fee Provisions.

No provision providing for the payment of prevailing party costs and expenses (including legal fees) resulting from litigation or other method of dispute resolution shall be applicable to Illinois Customers.

Automatic Renewals.

No provision calling for automatic renewals or "evergreen" renewals, (wherein the term of the agreement automatically renews for a period beyond the initial term unless a party provides affirmative advance notice of termination to the other party) shall be effective in an Agreement with an Illinois Customer, it being the parties' understanding, instead, that the contractual arrangements with Illinois Customers will terminate upon completion of the initial term or satisfaction of the original scope, unless the parties subsequently and affirmatively agree to supplemental renewal provisions.

Successors and Assigns; No Subcontracting.

Contractor shall not assign any rights under, or interest in, this Agreement, nor may Contractor subcontract any duties arising hereunder, without the prior written consent of the Illinois Customer. This Agreement shall be binding upon and inure to the benefit of the parties hereto and their respective successors and assigns.

8. Iowa, AEA Purchasing

A. Additional Member Agency General Terms and Conditions that apply for all categories

Right to Assign

AEA Purchasing specifically reserves the right, in its sole discretion, to assign and transfer its interest in the Contract with the Vendor Partner, consistent with the terms and conditions of said Contract, to any organization, along with all corresponding duties, responsibilities, and obligations of both parties, and under the terms provided herein.

B. Additional Member Agency Terms and Conditions for Non-Construction Products and Services

None.

C. Additional Member Agency Terms and Conditions for Construction Products and Services

AEA Purchasing may participate in Construction Products and Services bids through AEPA on a limited basis due to the restrictions mandated in the Iowa Code, Chapter 26 and 573.

D. Procedure for Processing Orders

AEA Purchasing's eligible clients follow a standard or electronic ordering process. The awarded Contractor will invoice and deliver products and services directly to AEA Purchasing's eligible clients. All invoices for payment shall be sent directly to the AEA Purchasing eligible client ordering under the terms and conditions of this agreement. The AEA Purchasing eligible client will make payment directly to the awarded Contractor(s). AEA Purchasing does not process any orders.

E. Agencies Allowed to Purchase under the Member Agency

- K-12 Public & Private Schools
- Area Education Agencies
- Colleges & Universities
- Public Libraries
- City, County & State Government
- Non-Profit Education Organizations

9. Kansas, Greenbush-Southeast Kansas Education Service Center (SEKESC)

A. Additional Member Agency General Terms and Conditions that apply for all categories

Kansas Mandatory Contract Provisions

Terms Herein Controlling Provisions: It is expressly agreed that the terms of each and every provision in this attachment shall prevail and control over the terms of any other conflicting provision in any other document relating to and a part of the contract in which this attachment is incorporated. Any terms that conflict or could be interpreted to conflict with this attachment are nullified.

Kansas Law and Venue: This contract shall be subject to, governed by, and construed according to the laws of the State of Kansas, and jurisdiction and venue of any suit in connection with this contract shall reside only in courts located in the State of Kansas.

Termination Due To Lack Of Funding Appropriation: If, in the judgment of the Director of Accounts and Reports, Department of Administration, sufficient funds are not appropriated to continue the function performed in this agreement and for the payment of the charges hereunder, State may terminate this agreement at the end of its current fiscal year. State agrees to give written notice of termination to contractor at least 30 days prior to the end of its current fiscal year, and shall give such notice for a greater period prior to the end of such fiscal year as may be provided in this contract, except that such notice shall not be required prior to 90 days before the end of such fiscal year. Contractor shall have the right, at the end of such fiscal year, to take possession of any equipment provided State under the contract. State will pay to the contractor all regular contractual payments incurred through the end of such fiscal year, plus contractual charges incidental to the return of any such equipment. Upon termination of the agreement by State, title to any such equipment shall revert to contractor at the end of the State's current fiscal year. The termination of the contract pursuant to this paragraph shall not cause any penalty to be charged to the agency or the contractor.

Disclaimer Of Liability: No provision of this contract will be given effect that attempts to require the State of Kansas or its agencies to defend, hold harmless, or indemnify any contractor or third party for any acts or omissions. The liability of the State of Kansas is defined under the Kansas Tort Claims Act (K.S.A. 75-6101 et seq.).

Anti-Discrimination Clause: The contractor agrees: (a) to comply with the Kansas Act Against Discrimination (K.S.A. 44-1001 et seq.) and the Kansas Age Discrimination in Employment Act (K.S.A. 44-1111 et seq.) and the applicable provisions of the Americans With Disabilities Act (42 U.S.C. 12101 et seq.) (ADA) and to not discriminate against any person because of race, religion, color, sex, disability, national origin or ancestry, or age in the admission or access to, or treatment or employment in, its programs or activities; (b) to include in all solicitations or advertisements for employees, the phrase "equal opportunity employer"; (c) to comply with the reporting requirements set out at K.S.A. 44-1031 and K.S.A. 44-1116; (d) to include those provisions in every subcontract or purchase order so that they are binding upon such subcontractor or vendor; (e) that a failure to comply with the reporting requirements of (c) above or if the contractor is found guilty of any violation of such acts by the Kansas Human Rights Commission, such violation shall constitute a breach of contract and the contract may be cancelled, terminated or suspended, in whole or in part, by the contracting state agency or the Kansas Department of Administration; (f) if it is determined that the contractor has violated applicable provisions of ADA, such violation shall constitute a breach of contract and the contract may be cancelled, terminated or suspended, in whole or in part, by the contracting state agency or the Kansas Department of Administration.

Contractor agrees to comply with all applicable state and federal anti-discrimination laws.

The provisions of this paragraph number 5 (with the exception of those provisions relating to the ADA) are not applicable to a contractor who employs fewer than four employees during the term of such contract or whose contracts with the contracting State agency cumulatively total \$5,000 or less during the fiscal year of such agency.

Acceptance Of Contract: This contract shall not be considered accepted, approved or otherwise effective until the statutorily required approvals and certifications have been given.

Arbitration, Damages, Warranties: Notwithstanding any language to the contrary, no interpretation of this contract shall find that the State or its agencies have agreed to binding arbitration, or the payment of damages or penalties. Further, the State of Kansas and its agencies do not agree to pay attorney fees, costs, or late payment charges beyond those available under the Kansas Prompt Payment Act (K.S.A. 75-6403), and no provision will be given effect that attempts to exclude, modify, disclaim or otherwise attempt to limit any damages available to the State of Kansas or its agencies at law, including but not limited to the implied warranties of merchantability and fitness for a particular purpose.

Representative's Authority To Contract: By signing this contract, the representative of the contractor thereby represents that such person is duly authorized by the contractor to execute this contract on behalf of the contractor and that the contractor agrees to be bound by the provisions thereof.

Responsibility For Taxes: The State of Kansas and its agencies shall not be responsible for, nor indemnify a contractor for, any federal, state or local taxes which may be imposed or levied upon the subject matter of this contract.

Insurance: The State of Kansas and its agencies shall not be required to purchase any insurance against loss or damage to property or any other subject matter relating to this contract, nor shall this contract require them to establish a "self-insurance" fund to protect against any such loss or damage. Subject to the provisions of the Kansas Tort Claims Act (K.S.A. 75-6101 et seq.), the contractor shall bear the risk of any loss or damage to any property in which the contractor holds title.

Information: No provision of this contract shall be construed as limiting the Legislative Division of Post Audit from having access to information pursuant to K.S.A. 46-1101 et seq.

The Eleventh Amendment: "The Eleventh Amendment is an inherent and incumbent protection with the State of Kansas and need not be reserved, but prudence requires the State to reiterate that nothing related to this contract shall be deemed a waiver of the Eleventh Amendment."

Campaign Contributions / Lobbying: Funds provided through a grant award or contract shall not be given or received in exchange for the making of a campaign contribution. No part of the funds provided through this contract shall be used to influence or attempt to influence an officer or employee of any State of Kansas agency or a member of the Legislature regarding any pending legislation or the awarding, extension, continuation, renewal, amendment or modification of any government contract, grant, loan, or cooperative agreement.

Assignment - SEKESC Right to Assign

In the event of a cancellation, the SEKESC specifically reserves the right, in its sole discretion, to assign and transfer its interest in any contract, consistent with the terms and conditions of any contract, to any organization, along with all corresponding duties, responsibilities for both parties and provisions contained herein.

Purchase Orders

Any purchase order issued by SEKESC, or one of its eligible entities, is cancelable under provisions of K.S.A. 10-1113. All purchase orders shall be issued by the SEKESC or its participating eligible entities desiring to acquire the products or services under the contract. Said purchase order shall include adequate reference to identify the bid to which it relates.

Marketing

- Awarded Vendor will proactively market the awarded contract to all eligible entities. The SEKESC will enhance the Awarded Vendor's marketing efforts through communication and meetings with eligible entities, participation in marketing events and tradeshow, through its website and social media resources and through day-to-day customer support activities.
- Awarded Vendor will train its professional staff and sales force in the provisions and benefits of the awarded contract. The SEKESC will enhance such effort by providing joint trainings and participating in joint sales calls as needed.
- The SEKESC and Awarded Vendor will jointly design presentations, documents, and other promotional material to assist in the promotion of the awarded contract.
- Awarded Vendor will include the SEKESC (Greenbush) logo on all sales materials targeted to eligible entities for the awarded contract. The SEKESC hereby grants to Awarded Vendor a non-exclusive, revocable, non-transferable, permission to use the SEKESC (Greenbush) name and logo during the term of this Agreement. Likewise, during the term of this agreement, the Awarded Vendor grants the SEKESC (Greenbush) permission to reproduce their name and logo in connection with marketing and promotion of the awarded contract.

B. Additional Member Agency Terms and Conditions for Non-Construction Products and Services
SEKESC has no additional terms and conditions for non-construction products and services.

C. Additional Member Agency Terms and Conditions for Construction Products and Services

K.S.A. 60-1111. Public works bond. (a) Bond by contractor. Except as provided in this section, whenever any public official, under the laws of the state, enters into contract in any sum exceeding \$100,000 with any person or persons for the purpose of making any public improvements, or constructing any public building or making repairs on the same, such officer shall take, from the party contracted with, a bond to the state of Kansas with good and sufficient sureties in a sum not less than the sum total in the contract, conditioned that such contractor or the subcontractor of such contractor shall pay all indebtedness incurred for labor furnished, materials, equipment or supplies, used or consumed in connection with or in or about the construction of such public building or in making such public improvements.

A contract which requires a contractor or subcontractor to obtain a payment bond or any other bond shall not require that such bond be obtained from a specific surety, agent, broker or producer. A public official entering into a contract which requires a contractor or subcontractor to obtain a payment bond or any other bond shall not require that such bond be obtained from a specific surety, agent, broker or producer.

(b) Filing and limitations. The bond required under subsection (a) shall be filed with the clerk of the district court of the county in which such public improvement is to be made. When such bond is filed, no lien shall attach under this article. Any liens which have been filed prior to the filing of such bond shall be discharged. Any person to whom there is due any sum for labor or material furnished, as stated in subsection (a), or such person's assigns, may bring an action on such bond for the recovery of such indebtedness but no action shall be brought on such bond after six months from the completion of such public improvements or public buildings.

(c) In any case of a contract for construction, repairs or improvements for the state or a state agency under K.S.A. 75-3739 or 75-3741, and amendments thereto, a certificate of deposit payable to the state may be accepted in accordance with and subject to K.S.A. 60-1112, and amendments thereto. When such certificate of deposit is so accepted, no lien shall attach under this article. Any liens which have been filed prior to the acceptance of such certificate of deposit shall be discharged. Any person to whom there is due any sum for labor furnished, materials, equipment or supplies used or consumed in connection with or for such contract for construction, repairs or improvements shall make a claim therefor with the director of purchases under K.S.A. 60-1112, and amendments thereto.

D. Procedure for Processing Orders

The SEKESC utilizes the following ordering/delivery procedures:

- Purchase orders will be issued by the individual eligible entity.
- Vendors must issue invoices directly to the ordering eligible entity as specified on each purchase order.
- Delivery of all items included in this solicitation will be made to the locations within each eligible entity as will be specified on the purchase order.
- Each order shall contain a packing slip of its contents to assist in prompt processing of payments to Vendor.

Additionally

- Awarded Vendor agrees to demonstrate the benefit of the pricing agreement with the SEKESC over alternative options, including competitive solicitation pricing.
- Awarded Vendor agrees to proactively offer terms and pricing under this agreement to eligible entities and a more effective alternative to the cost and time associated with alternate bids and solicitation.
- When responding to third party procurement solicitations, Awarded Vendor may:
 - Choose not to respond and make this agreement available as an alternative and comparison to the agency's solicitation responses.
 - Respond with pricing, terms, and conditions of this agreement. If awarded the contract, sales will be reported as defined in the solicitation.
 - Provide lower prices when the competitive process requires without being required to extend the lower pricing to all eligible entities. In such case, if Awarded Vendor is awarded the contract, the sales will be reported as defined in the solicitation.
 - Respond to the solicitation with higher pricing than is available through this agreement and if an alternative response is permitted, may offer the pricing under this agreement as an alternative for consideration. If Awarded Vendor is awarded the contract with alternative SEKESC pricing, the resulting sales will be reported as defined in the solicitation.
- Provide notification to the SEKESC of the response to a solicitation, including but not limited to the name of the soliciting agency, general description of scope, timeline, and resulting award or non-award. Such notification shall be submitted to Tina Smith at tina.smith@greenbush.org within 5 business days of the proposal submission and resulting award information within 5 business days of agency's notification to Awarded Vendor.

E. Agencies Allowed to Purchase under the Member Agency

Eligible Entities: Entities eligible to purchase from Southeast Kansas Education Service Center (Greenbush) cooperative purchasing contracts include but may not be limited to:

- K-12 Public Schools
- K-12 Private Schools
- Colleges & Universities
- City, County, and State Governments
- Public Libraries
- Non-profit organizations holding form #501C3

10. Kentucky, Green River Regional Educational Cooperative (GRREC)

A. Additional Member Agency General Terms and Conditions that apply for all categories

The Green River Regional Educational Cooperative, Inc. (GRREC) is one of eight educational cooperatives in Kentucky, all of which are participants in the AEPA bids. GRREC serves as contact agency for all AEPA correspondence for all eight educational cooperatives. For the Kentucky Educational Cooperatives, the collective bidding process is conducted consistent with KRS Chapter 45A, the Kentucky Model Procurement Code. Contracts with GRREC shall include the provision granting GRREC employees the right to access to the Contractor's records.

Vendor Contact: Vendor will designate to GRREC one individual who will represent them to Kentucky Bidding Cooperative members during the agreement period. This contact person will correspond with each ordering member for technical assistance, problems, or questions that may arise. Include instructions if different contacts for different geographical areas are needed; this information will be distributed to Kentucky Bidding Cooperative members upon award of this bid.

The following Federal Clauses are required as a part of KY bid documents:

1. **CLEAN AIR/CLEAN WATER**
 - A. Vendor Partner agrees to comply with all applicable standards, orders or regulations issued pursuant to the Federal Water Pollution Control Act as amended (33 U.S.C. §§ 1251 et seq). Vendor Partner agrees to report each violation to the USDA and the appropriate EPA Regional Office.
 - B. Vendor Partner agrees to comply with all applicable standards, orders or regulations issued pursuant to the Clean Air Act, as amended, 42 U.S.C. §§ 7401 et seq. Vendor Partner agrees to report each violation to the USDA and the appropriate EPA Regional Office.
2. **SUSPENSION AND DEBARMENT**

Vendor Partner understands that a contract award (see 2 CFR 180.220) must not be made to parties listed on the government wide exclusions in the System for Award Management (SAM), in accordance with the OMB guidelines at 2 CFR 180 that implement Executive Orders 12549 (3 CFR part 1986 Comp., p. 189) and 12689 (3 CFR part 1989 Comp., p. 235), "Debarment and Suspension." By signing and submitting its bid or proposal, the bidder or proposer certifies as follows: The certification in this clause is a material representation of fact relied upon by GRREC. If it is later determined that Vendor Partner knowingly rendered an erroneous certification, in addition to remedies available to GRREC, the Federal Government may pursue available remedies, including but not limited to suspension and/or debarment. Vendor Partner agrees to comply with the requirements of 2 CFR 180.220 while the above-referenced contract is valid. Vendor Partner further agrees to include a provision requiring such compliance in its lower tier covered transactions.
3. **LOBBYING**

Vendor Partner will comply with the Byrd Anti-Lobbying Amendment (31 U.S.C. § 1352) and the New Restrictions on Lobbying and has signed and attached to this Addendum the Certificate Regarding Lobbying and, if applicable, the Disclosure of Lobbying Activities (Forms SF-LLL) and annually will sign and submit a certificate, if applicable, Form SF-LLL to GRREC.
4. **PROCUREMENT OF RECOVERED MATERIALS PURSUANT TO 2 C.F.R. § 200.322**

Vendor Partner agrees to comply with section 6002 of the Solid Waste Disposal Act, as amended by the Resource Conservation and Recovery Act.
5. **BUY AMERICAN**

"Domestic Commodity or Product" are defined as an agricultural commodity that is produced in the United States and a food product that is processed in the United States using substantial agricultural commodities that are produced in the United States. "Substantial" means that over 51 percent of the final processed product consists of agricultural commodities that were grown domestically.

Products from Guam, American Samoa, Virgin Islands, Puerto Rico, and the Northern Mariana Islands are allowed under this provision as territories of the United States.

The Buy American provision (7 CFR Part 210.21(d)) is one of the procurement standards School Food Authorities ("SFAs") must comply with when purchasing commercial food products served in the school meals programs.

Buy American: AEPA Member Agencies or Participating Entities participating in the federal school meal programs are required to purchase domestic commodities and products for school meals to the maximum extent practicable. Domestic commodity or product means an agricultural commodity that is produced in the US and a food product that is processed in the US substantially (at least 51 percent) using agricultural commodities that are produced in the US.

Federal regulations require that all foods purchased for Child Nutrition Program be of domestic origin to the maximum extent practicable. While rare, two (2) exceptions may exist when: the product is not produced or

Manufactured in the US in sufficient, reasonable and available quantities of a satisfactory quality, such as bananas and pineapple; and competitive proposals reveal the cost of a domestic product is significantly higher than a non-domestic product.

ALL products that are normally purchased by Vendor Partner as non-domestic and proposed as part of this contract must be identified with the country of origin. Vendor Partner shall outline their procedures to notify GRREC when products are purchased as non-domestic.

Any substitution of a non-domestic product for a domestic product (which was originally a part of the solicitation), must be approved, in writing, by GRREC, prior to the delivery of the product to the AEPA Member Agency or Participating Entities. Any non-domestic product delivered to the AEPA Member Agencies or Participating Entities, without the prior, written approval of GRREC will be rejected.

Vendor Partner must affirm its willingness to assert its best and reasonable efforts to ensure compliance with this federal rule.

6. COST REIMBURSEMENT CONTRACTS

Solicitation Requirements for cost reimbursable contracts:

- A. Allowable costs will be paid from the nonprofit school food service account to the contractor net of all discounts, rebates and other applicable credits accruing to or received by the contractor or any assignee under the contract, to the extent those credits are allocable to the allowable portion of the costs billed to the school food authority;
- B. Contractor will separately identify for each cost submitted for payment to the school food authority the amount of that cost that is allowable (can be paid from the nonprofit school food service account) and the amount that is unallowable (cannot be paid from the nonprofit school food service account); or (B) Contractor will exclude all unallowable costs from its billing documents and certify that only allowable costs are submitted for payment and records have been established that maintain the visibility of unallowable costs, including directly associated costs in a manner suitable for contract cost determination and verification;
- C. Contractor's determination of its allowable costs will be made in compliance with the applicable Departmental and Program regulations and Office of Management and Budget cost circulars;
- D. Contractor will identify the amount of each discount, rebate and other applicable credit on bills and invoices presented to the school food authority for payment and individually identify the amount as a discount, rebate, or in the case of other applicable credits, the nature of the credit;
- E. Contractor must identify the method by which it will report discounts, rebates and other applicable credits allocable to the contract that are not reported prior to conclusion of the contract; and
- F. Contractor must maintain documentation of costs and discounts, rebates and other applicable credits, and must furnish such documentation upon request to the school food authority, the State agency, or the Department.

B. Additional Member Agency Terms and Conditions for Construction Products and Services

The Contractor and subcontractors shall pay all laborers, workmen and mechanics performing work under this contract not less than the rate of wages set forth in the prevailing wage schedule incorporated in the contract conditions as determined by the Kentucky Department of Labor in accordance with the provisions of KRS 337.505 through KRS 337.550.

Bidders are informed that construction contracts of the Commonwealth of Kentucky and political subdivisions are not exempt from the provisions of the Kentucky Sales and/or Use Tax. Current sales and/or Use Tax shall be provided for and included in the bid amount as no adjustments will be permitted nor made after receipt of bids.

1. It should be noted that where performance bonds are required, it should include both performance and payment bonds.
2. State Prevailing Wages shall apply for projects of \$250,000.00 or more, or Davis Bacon wages (when federal funds are utilized) if higher than State Prevailing Wages.
3. All work shall be in accordance with necessary approvals from the Kentucky Department of Housing, Buildings and Construction and the Kentucky Building Code.
4. All processes of the project comply with 702 KAR 4:160, the Capital Construction Process, including necessary approvals from the Kentucky Department of Education.
5. Performance and payment bond on AIA document 312 must be provided for all projects that exceed \$25,000. (Also provide that the Surety shall comply with state requirements.)
6. In accordance with 702 KAR 4:160, AIA and KDE documents be utilized on all projects including but limited to:

- a. A 101 Standard form of Agreement between Owner and Contractor (including KDE amendments)
 - b. A 201 General Conditions of the Standard Form of Agreement between Owner and Contractor (including KDE amendments)
 - c. AIA A701 Instructions to bidders, with KDE amendment and KDE Form of proposal (may require editing AEPA instructions to bidders to eliminate conflicts).
 - d. KDE purchase Order (for direct purchase of materials with tax number, to exempt materials from state sales tax)
 - e. If applicable, where architectural services are provided by the Owner, Form B141, Standard Form of Agreement between Owner and Architect
7. Architectural services shall be provided in accordance with KRS 322.360 and other relevant Kentucky Revised Statutes by the vendor or the Owner at the Owner's preference.

C. Procedure for Processing Orders

Once the award is made to the Contractor/vendor, GRREC and Kentucky's other cooperatives will inform their members (school districts and other entities) of the contract by: 1) including the contract in the Current Bids section on their websites and 2) publishing the contract information in catalogs disseminated to all members. A list of members, contact names, addresses and phone numbers is made available to the Contractor. At this point the Contractor/vendor contacts the members and members may contact the Contractor/vendor. When the member identifies a product or service, it will issue a purchase order for that item to the vendor. The vendor's price will include a two percent (2%) administrative fee that the vendor will collect from the member and remit to GRREC on a quarterly basis. Municipal and county governments, and other governmental, quasi-governmental, or nonprofit organization price will reflect a two percent (2%) administrative fee. On the occasion that an AEPA contract awarded by Kentucky is utilized by public school and public non-school entities in other states, purchases in these instances will also reflect a two percent (2%) administrative fee. The vendor will also compile and provide to GRREC a quarterly report showing all purchases made by Kentucky members (with specific detail as to what purchases were made by which members) under this contract. Further, if no purchases are made in any given quarter, the Vendor shall remit a "No Activities" statement to GRREC for that quarter. The vendor will also produce and provide to GRREC an annual summary report for all purchases made under this contract for a period of beginning with the award of the contract through December 31st and all consecutive annual periods if contract is extended. The vendor will make all administrative fee payments to the GRREC by the 15th of the month following the end of the quarter (i. e. April 15th, July 15th, October 15th and January 15th). All checks are to be made payable to GRREC and sent to GRREC, 230 Technology Way, Bowling Green, KY 42101 and Attention: Bids Coordinator. GRREC may designate another agent for collecting an administrative fee that will be negotiated with vendor for e-commerce transaction. GRREC will share information from the quarterly and annual reports and distribute the administrative fee among the other KY Educational Cooperatives according to membership.

D. Members Purchasing under the Agency

Currently there are 8 Bidding Cooperatives in Kentucky and all are participating in this invitation through GRREC's solicitation. There are 170+ independent and county school districts and all are eligible for membership in a Bidding Cooperative and approximately 98% of the districts are members of one of the cooperatives. No district is obligated to use these services. Additional members may include other public educational institutions in the state, public colleges or universities, community colleges, vocational or technical schools, municipal and county governments, and other governmental, quasi-governmental or non-profit organizations. Kentucky currently shares its AEPA contracts with the following states: AL, GA, LA, MS, NC, SC, and TN. Only those districts or institutions listed on an approved Bidding Cooperative membership list are eligible to purchase under these contracts. This list may change during the contract period

11. Massachusetts, The Education Cooperative

This Commonwealth Terms and Conditions form is jointly issued by the Executive Office for Administration and Finance (ANF), the Office of the Comptroller (CTR) and the Operational Services Division (OSD) for use by all Commonwealth of Massachusetts ("State") Departments and Contractors. **Any changes or electronic alterations by either the Department or the Contractor to the official version of this form, as jointly published by ANF, CTR and OSD, shall be void.** Upon execution of these Commonwealth Terms and Conditions by the Contractor and filing as prescribed by the Office of the Comptroller, these Commonwealth Terms and Conditions will be incorporated by reference into any Contract for Commodities and Services executed by the Contractor and any State Department, in the absence of a superseding law or regulation requiring a different Contract form. Performance shall include services rendered, obligations due, costs incurred, commodities and deliverables provided and accepted by the Department, programs provided or other commitments authorized under a Contract. A deliverable shall include any tangible product to be delivered as an element of performance under a Contract. The Commonwealth is entitled to ownership and possession of all deliverables purchased or developed with State funds. Contract shall mean the Standard Contract Form issued jointly by ANF, CTR and OSD.

1. Contract Effective Start Date. Notwithstanding verbal or other representations by the parties, or an earlier start date indicated in a Contract, the effective start date of performance under a Contract shall be the date a Contract has been executed by an authorized signatory of the Contractor, the Department, a later date specified in the Contract or the date of any approvals required by law or regulation, whichever is later.

2. Payments And Compensation. The Contractor shall only be compensated for performance delivered and accepted by the Department in accordance with the specific terms and conditions of a Contract. All Contract payments are subject to appropriation pursuant to M.G.L. C. 29, §26, or the availability of sufficient non-appropriated funds for the purposes of a Contract, and shall be subject to intercept pursuant to M.G.L. C. 7A, §3 and 815 CMR 9.00. Overpayments shall be reimbursed by the Contractor or may be offset by the Department from future payments in accordance with state finance law. Acceptance by the Contractor of any payment or partial payment, without any written objection by the Contractor, shall in each instance operate as a release and discharge of the State from all claims, liabilities or other obligations relating to the performance of a Contract.

3. Contractor Payment Mechanism. All Contractors will be paid using the Payment Voucher System unless a different payment mechanism is required. The Contractor shall timely submit invoices (Payment Vouchers - Form PV) and supporting documentation as prescribed in a Contract. The Department shall review and return rejected invoices within fifteen (15) days of receipt with a written explanation for rejection. Payments shall be made in accordance with the bill paying policy issued by the Office of the Comptroller and 815 CMR 4.00, provided that payment periods listed in a Contract of less than forty-five (45) days from the date of receipt of an invoice shall be effective only to enable a Department to take advantage of early payment incentives and shall not subject any payment made within the forty-five (45) day period to a penalty. The Contractor Payroll System, shall be used only for "Individual Contractors" who have been determined to be "Contract Employees" as a result of the Department's completion of an Internal Revenue Service SS-8 form in accordance with the Omnibus Budget Reconciliation Act (OBRA) 1990, and shall automatically process all state and federal mandated payroll, tax and retirement deductions.

4. Contract Termination Or Suspension. A Contract shall terminate on the date specified in a Contract, unless this date is properly amended in accordance with all applicable laws and regulations prior to this date, or unless terminated or suspended under this Section upon prior written notice to the Contractor. The Department may terminate a Contract without cause and without penalty, or may terminate or suspend a Contract if the Contractor breaches any material term or condition or fails to perform or fulfill any material obligation required by a Contract, or in the event of an elimination of an appropriation or availability of sufficient funds for the purposes of a Contract, or in the event of an unforeseen public emergency mandating immediate Department action. Upon immediate notification to the other party, neither the Department nor the Contractor shall be deemed to be in breach for failure or delay in performance due to Acts of God or other causes factually beyond their control and without their fault or negligence. Subcontractor failure to perform or price increases due to market fluctuations or product availability will not be deemed factually beyond the Contractor's control.

5. Written Notice. Any notice shall be deemed delivered and received when submitted in writing in person or when delivered by any other appropriate method evidencing actual receipt by the Department or the Contractor. Any written notice of termination or suspension delivered to the Contractor shall state the effective date and period of the notice, the reasons for the termination or suspension, if applicable, any alleged breach or failure to perform, a reasonable period to cure any alleged breach or failure to perform, if applicable, and any instructions or restrictions concerning allowable activities, costs or expenditures by the Contractor during the notice period.

6. Confidentiality. The Contractor shall comply with M.G.L. C. 66A if the Contractor becomes a "holder" of "personal data". The Contractor shall also protect the physical security and restrict any access to personal or other Department data in the Contractor's possession, or used by the Contractor in the performance of a Contract, which shall include, but is not limited to the Department's public records, documents, files, software, equipment or systems.

7. Record-keeping And Retention, Inspection Of Records. The Contractor shall maintain records, books, files and other data as specified in a Contract and in such detail as shall properly substantiate claims for payment under a Contract, for a minimum retention period of seven (7) years beginning on the first day after the final payment under a Contract, or such longer period as is necessary for the resolution of any litigation, claim, negotiation, audit or other inquiry involving a Contract. The Department shall have access, as well as any parties identified under Executive Order 195, during the Contractor's regular business hours and upon reasonable prior notice, to such records, including on-site reviews and reproduction of such records at a reasonable expense.

8. Assignment. The Contractor may not assign or delegate, in whole or in part, or otherwise transfer any liability, responsibility, obligation, duty or interest under a Contract, with the exception that the Contractor shall be authorized to assign present and prospective claims for money due to the Contractor pursuant to a Contract in accordance with M.G.L. C. 106, §9-318. The Contractor must provide sufficient notice of assignment and supporting documentation to enable the Department to verify and implement the assignment. Payments to third party assignees will be processed as if such payments were being made directly to the Contractor and these payments will be subject to intercept, offset, counter claims or any other Department rights which are available to the Department or the State against the Contractor.

9. Subcontracting By Contractor. Any subcontract entered into by the Contractor for the purposes of fulfilling the obligations under a Contract must be in writing, authorized in advance by the Department and shall be consistent with and subject to the provisions of these Commonwealth Terms and Conditions and a Contract. Subcontracts will not relieve or discharge the Contractor from any duty, obligation, responsibility or liability arising under a Contract. The Department is entitled to copies of all subcontracts and shall not be bound by any provisions contained in a subcontract to which it is not a party.

10. Affirmative Action, Non-Discrimination In Hiring And Employment. The Contractor shall comply with all federal and state laws, rules and regulations promoting fair employment practices or prohibiting employment discrimination and unfair labor practices and shall not discriminate in the hiring of any applicant for employment nor shall any qualified employee be demoted, discharged or otherwise subject to discrimination in the tenure, position, promotional opportunities, wages, benefits or terms and conditions of their employment because of race, color, national origin, ancestry, age, sex, religion, disability, handicap, sexual orientation or for exercising any rights afforded by law. The Contractor commits to purchasing supplies and services from certified minority or women-owned businesses, small businesses or businesses owned by socially or economically disadvantaged persons or persons with disabilities.

11. Indemnification. Unless otherwise exempted by law, the Contractor shall indemnify and hold harmless the State, including the Department, its agents, officers and employees against any and all claims, liabilities and costs for any personal injury or property damages, patent or copyright infringement or other damages that the State may sustain which arise out of or in connection with the Contractor's performance of a Contract, including but not limited to the negligence, reckless or intentional conduct of the Contractor, its agents, officers, employees or subcontractors. The Contractor shall at no time be considered an agent or representative of the Department or the State. After prompt notification of a claim by the State, the Contractor shall have an opportunity to participate in the defense of such claim and any negotiated settlement agreement or judgment. The State shall not be liable for any costs incurred by the Contractor arising under this paragraph. Any indemnification of the Contractor shall be subject to appropriation and applicable law.

12. Waivers. Forbearance or indulgence in any form or manner by a party shall not be construed as a waiver, nor in any way limit the legal or equitable remedies

available to that party. No waiver by either party of any default or breach shall constitute a waiver of any subsequent default or breach.

13. Risk Of Loss. The Contractor shall bear the risk of loss for any Contractor materials used for a Contract and for all deliverables, Department personal or other data which is in the possession of the Contractor or used by the Contractor in the performance of a Contract until possession, ownership and full legal title to the deliverables are transferred to and accepted by the Department.

14. Forum, Choice of Law And Mediation. Any actions arising out of a Contract shall be governed by the laws of Massachusetts, and shall be brought and maintained in a State or federal court in Massachusetts which shall have exclusive jurisdiction thereof. The Department, with the approval of the Attorney General's Office, and the Contractor may agree to voluntary mediation through the Massachusetts Office of Dispute Resolution (MODR) of any Contract dispute and will share the costs of such mediation. No legal or equitable rights of the parties shall be limited by this Section.

15. Contract Boilerplate Interpretation, Severability, Conflicts With Law, Integration. Any amendment or attachment to any Contract which contains conflicting language or has the affect of a deleting, replacing or modifying any printed language of these Commonwealth Terms and Conditions, as officially published by ANF, CTR and OSD, shall be interpreted as superseded by the official printed language. If any provision of a Contract is found to be superseded by state or federal law or regulation, in whole or in part, then both parties shall be relieved of all obligations under that provision only to the extent necessary to comply with the superseding law, provided however, that the remaining provisions of the Contract, or portions thereof, shall be enforced to the fullest extent permitted by law. All amendments must be executed by the parties in accordance with Section 1. of these Commonwealth Terms and Conditions and filed with the original record copy of a Contract as prescribed by CTR. The printed language of the Standard Contract Form, as officially published by ANF, CTR and OSD, which incorporates by reference these Commonwealth Terms and Conditions, shall supersede any conflicting verbal or written agreements relating to the performance of a Contract, or attached thereto, including contract forms, purchase orders or invoices of the Contractor. The order of priority of documents to interpret a Contract shall be as follows: the printed language of the Commonwealth Terms and Conditions, the Standard Contract Form, the Department's Request for Response (RFR) solicitation document and the Contractor's Response to the RFR solicitation, excluding any language stricken by a Department as unacceptable and including any negotiated terms and conditions allowable pursuant to law or regulation.

IN WITNESS WHEREOF, The Contractor certify under the pains and penalties of perjury that it shall comply with these Commonwealth Terms and Conditions for any applicable Contract executed with the Commonwealth as certified by their authorized signatory below:

CONTRACTOR AUTHORIZED SIGNATORY: _____
(signature)

Print Name:

Title:

Date:

(Check One): Organization Individual

Full Legal Organization or Individual Name:

Doing Business As: Name (If Different):

Tax Identification Number:

Address:

Telephone: FAX:

INSTRUCTIONS FOR FILING THE COMMONWEALTH TERMS AND CONDITIONS

A "Request for Verification of Taxation Reporting Information" form (Massachusetts Substitute W-9 Format), that contains the Contractor's correct TIN, name and legal address information, must be on file with the Office of the Comptroller. If the Contractor has not previously filed this form with the Comptroller, or if the information contained on a previously filed form has changed, please fill out a W-9 form and return it attached to the executed COMMONWEALTH TERMS AND CONDITIONS.

If the Contractor is responding to a Request for Response (RFR), the COMMONWEALTH TERMS AND CONDITIONS must be submitted with the Response to RFR or as specified in the RFR. Otherwise, Departments or Contractors must timely submit the completed and properly executed COMMONWEALTH TERMS AND CONDITIONS (and the W-9 form if applicable) to the: **Payee and Payments Unit, Office of the Comptroller, 9th Floor, One Ashburton Place, Boston, MA 02108** in order to record the filing of this form on the MMARS Vendor File. Contractors are required to execute and file this form only once.

12. Michigan, Oakland Schools, (OS)

A. Additional Member Agency General Terms and Conditions that apply for all categories:

1. Conflict of Interest

Contractor shall disclose in writing to Buyer any conflicts of interest with Board members, administrators, and or employees of any Participating Entity (as defined below). A conflict of interest may include, but is not limited to, a financial ownership interest in, or employment with Contractor or Subcontractor by a Participating Entity' Board member, administrator, or employee or their family member. A "family member" means a person's spouse or spouse's sibling or child; a person's sibling or sibling's spouse or child; a person's child or child's spouse; or a person's parent or parent's spouse, and includes these relationships as created by adoption or marriage. Determination of the existence of a conflict of interest does not prohibit the Participating Entity from entering into a contract with the Contractor (MCL 380.634; MCL 15.322 et seq).

2. Termination of Buyer's Purchase Order

Default is defined as the failure of a Contractor to fulfill the contract, including but not limited to, not honoring bid prices, failure to deliver on time, or the unauthorized substitution of items or failure to comply with any or all of the specifications and/or terms and conditions contained in this solicitation or the contract/purchase order of a Participating Entity.

Should the Contractor fail to satisfactorily resolve the default, the contract/purchase order may be terminated with thirty (30) days written notice. In that event, the Contractor shall be held liable to the Participating Entity for all costs and expenses incurred by the Participating Entity arising out of said default. Notwithstanding the foregoing, each Participating Entity may terminate their contract/purchase order, with or without cause, or discontinue purchasing from the Contractor at any time.

3. Iran Economic Sanctions Act

Public Act 517 of 2012, commonly known as the "Iran Economic Sanctions Act" (the "Act"). The Act provides that beginning April 1, 2013, an "Iran Linked Business" is not eligible to submit a bid on a request for proposal with a "public entity" (OS). The Act also requires that a person that submits a proposal in response to an OS request for proposal must certify to the public entity that it is not an Iran Linked Business. This requirement applies to all requests for proposals issued by OS, and not just to construction projects.

The Act defines an Iran Linked Business as:

- a. A person engaging in investment activities in the energy sector of Iran, including a person that provides oil or liquefied natural gas tankers or products used to construct or maintain pipelines used to transport oil or liquefied natural gas for the energy sector of Iran;
- b. A financial institution that extends credit to another person, if that person will use the credit to engage in investment activities in the energy sector of Iran.

If the OS determines, using credible information available to the public, that a person or entity has submitted a false certification, OS must provide written notice to the person or entity of its determination and of its intent not to enter into or renew the contract. The notice must include information on how to contest the determination. The notice must also specify that the individual or entity may become eligible for future contracts with the public entity if the activities that caused it to be an Iran Linked Business are ceased.

4. Taxes

The Participating Entities are exempt from State Sales Taxes and such taxes shall not be included in any solicitation prices. Exemption certificates will be provided upon request.

5. Hazardous Materials

If any hazardous chemicals are supplied under a contract/purchase order arising out of this solicitation, a Material Safety Data Sheet (MSDS) shall accompany the delivery of any hazardous chemicals supplied by the Contractor. All MSDS sheets shall be sent to the attention of the Participating Entity. Ref: State of Michigan Act 154, Section 14, P.A. 1974 as amended. Copies of MSDS for all purchased hazardous materials must be provided prior to delivery of any

items by the Contractor. Additionally, the MSDS needs to be attached to the invoice and all products delivered must be labeled according to Section 14 of Act 154, of the public Acts of 1974, as amended. Any appropriate products not labeled will be refused and the Contractor will be responsible for additional freight charges. Payment may be withheld until the Participating Entity receives the MSDS.

6. Modifications to Contracts

No modifications to a contract/purchase order with a Participating Entity shall be binding upon such Participating Entity unless agreed to in writing signed by an authorized representative of the Participating Entity.

7. Indemnification

Contractor agrees to indemnify, defend and hold harmless OS, each Participating Entity and each Other Agency, including their Board of Educations or governing body, in their official and individual capacities, employees, agents, successors and assignees, from and against any and all costs, expenses, damages, and liabilities, including reasonable attorney's fees, arising out of the: (i) negligent act or omission or willful misconduct of the Contractor, its officers, directors, employees, successors, assignees, Contractors and agents; (ii) any breach of the terms of the contract between the Participating Entity and the Contractor; or (iii) any breach of any representation or warranty by Contractor under the contract with a Participating Entity or this solicitation.

8. Anti-discrimination

The Contractor hereby agrees to comply with all federal, state and municipal equal opportunity and antidiscrimination guidelines and regulations, and covenants that the Contractor will not discriminate against an employee or applicant for employment with respect to hire, tenure terms, conditions or privileges of employment, or in a manner directly or indirectly related to employment, because of race, color, religion, national origin, age, sex, height, marital status or disability. Failure on the part of the Contractor to comply with said guidelines and regulations shall, upon reasonable notice, constitute grounds for a Participating Entity to revoke and otherwise terminate the contract and all obligations of the Participating Entity hereunder.

9. Local Contract Terms and Conditions

For procurements of supplies, materials, equipment and/or services resulting from this solicitation, it is clearly understood and agreed to by the Contractor that any clause, term, or condition not addressed in this solicitation, but required by a Participating Entity, shall be adhered to by said Contractor.

Participating Entities, other than from K-12, choosing to purchase from awarded AEPA contracts are subject to their own respective laws, and/or local policy, procedures, and/or Charters

10. Governing Law

Any contract arising out of this solicitation shall be governed by and construed under the laws of the State of Michigan. In the event of any legal action to enforce or interpret any contract arising out of this solicitation, the sole and exclusive venue shall be the state or federal court of the local jurisdiction where the Participating Entities located.

B. Additional Member Agency Terms and Conditions for:

1. Non-Construction Products and Services:

All supplies, materials, and equipment sold or leased to Michigan intermediate school districts or K-12 public school districts must be in accordance with MCL 380.623a and 380.1274, respectively. The procurement of supplies, materials and/or equipment in a single transaction costing more than the State of Michigan Competitive Bidding threshold set forth in MCL 380.623a and 380.1274 by an intermediate school districts or K-12 public school districts requires the district to obtain competitive bids and the purchase must be approved by the district's Board of Education.

2. Construction Products and Services:

All Contractors understand and agree that the use of AEPA contracts is not intended for use by Michigan intermediate school districts or public K-12 school districts for construction, renovation or remodeling projects under MCL 380.1267 and agree to comply with all applicable standards and statutes for said construction projects.

C. Procedure for Processing Orders:

Once the award is made to a Contractor, OS will inform the Participating Entities and Other Agencies of the award by announcing the award through its general and usual methods of disseminating information.

1. OS follows the AEPA Standard Ordering Process (see Part A, General Terms and Conditions for All Agencies, “Ordering Procedures”).
2. Contractors shall be required to pay a two percent (2%) administrative fee (the “Fee”) based on the total cost of goods or services purchased, including installation and freight, if applicable. In the event of a lease arrangement, the total Fee for the value of goods leased shall be paid to OS by the Contractor at the front end of the lease. Contractor or its designated authorized reseller(s) shall not include any additional amount corresponding to the Fee in the bid responses or awarded prices.

D. Agencies Allowed to Purchase under the Member Agency:

OS serves all local school districts located in Oakland County, Michigan. In addition to, and in accordance with the terms and conditions set forth in this solicitation, all **public school districts, private schools, public school academies, intermediate school districts colleges, universities, counties, cities, townships, villages, and non-profit organization** in the State of Michigan shall be permitted to use AEPA solicitations approved by OS.

It should be clearly understood that OS is assisting these Participating Entities as a service to procure selected supplies, materials and equipment and services desired by the Participating Entity. Both the Contractor and any Participating Entity using this solicitation agree that the OS makes no representation that use of this solicitation by any Participating Entity is, in fact, in compliance with rules, regulations, policy or procedures of the Participating Entity. In this regard, the OS strongly suggests that, at a minimum, the Contractor and any Participating Entity considering such use consult with their own legal counsels before doing so. All Participating Entities using AEPA solicitations shall be responsible for adhering to their own applicable rules, regulations, policies, procedures and state statutes, etc., which may govern the use of cooperative purchasing contracts within their respective jurisdictions.

13. Minnesota, Cooperative Purchasing Connection (CPC)

General Terms and Conditions that apply for all categories

Governing Law: The laws of the State of Minnesota govern all contracts resulting from this IFB. Each and every provision of law and clause required by law to be included in a contract shall be deemed to be inserted herein and the contract shall be read and enforced as though it were included. If through mistake or otherwise any such provision is not included, or is not currently included, then upon application of either party the Contract shall be physically amended to make such inclusion or correction.

Governing Venue: The resulting contract award shall be deemed to have been made and performed in Otter Tail County, Minnesota. For the purpose of venue, all legal arbitration or causes for action arising out of the resulting agreement shall be brought to the courts of Otter Tail County, Minnesota.

Hazardous Substances: All hazardous products purchased by members shall include a Safety Data Sheet (SDS) with the delivery.

Lease and Rental Agreements: The Vendor may allow participating agencies to enter into a rental, lease, or lease purchase agreements, providing such agreements are in compliance with Minnesota Statutes and guidelines. CPC must receive a report annually, summarizing the executed lease purchases along with a summary of the participating agencies' purchases. CPC will not collect lease payments or be involved in the terms and conditions of the lease. All lease arrangements are between the Vendor and the participating agency. The Vendor agrees that leases will be in compliance with the Uniform Commercial Code. The applicable administrative fee must be included in the lease cost based on the total value of the goods and applicable services purchased. This fee is referred to under the Technical Specifications. The Vendor should attempt to work with CPC's current leasing vendor. Note, the current leasing vendor may require a minimum purchase amount to begin the leasing process. Should the Vendor be required to utilize their own financial leasing company, this should be noted/requested as an exception. In the event of a lease, the total administrative fee for the value of goods shall be paid to CPC by the vendor at the front end of the lease. CPC reserves the right to review all purchase orders, lease documents and invoices to insure contract compliance.

Marketing and Promotion: Upon award and completion of the vendor orientation, CPC will promote the contract opportunity via its websites. CPC will also announce the new partnership in its newsletters and will publish the contract and marketing information through hard copy marketing items (i.e. flyers, postcard) and electronic email. Contracts will also be promoted at applicable trade shows, conferences, and meetings on a regular basis. CPC may assist in the development of these materials if requested by the Vendor, but in all cases shall have the authority to review and approve any marketing materials. If a website is used, the link will be made available from the CPC and NDESC websites. Any web page or link, or other marketing tools shall be dedicated to CPC information only.

Non-Discrimination: Any resulting contract for on or behalf of participating agencies, said Vendor agrees to:

- That, in the hiring of common or skilled labor for the performance of any work under any contract, or any subcontract, no contractor, material supplier, or vendor, shall, by reason of race, creed, or color, discriminate against the person or persons who are citizens of the United States or resident aliens who are qualified and available to perform the work to which the employment relates;
- That no contractor, material supplier, or vendor, shall, in any manner, discriminate against, or intimidate, or prevent the employment of any person or persons identified in clause (1) of this section, or on being hired, prevent, or conspire to prevent, the person or persons from the performance of work under any contract on account of race, creed, or color;
- That a violation of this section is a misdemeanor; and
- That this contract may be canceled or terminated by the state, county, city, town, school board, or any other person authorized to grant the contracts for employment, and all money due, or to become due under the contract, may be forfeited for a second or any subsequent violation of the terms or conditions of this contract.

Participating Agency: A participating agency shall be defined in accordance with the, Minnesota Statutes M.S. §471.59, and M.S. §123A.21, Sub. 11 and South Dakota Statutes §5-18A-37. An eligible agency includes any school, higher education, city, county, other governmental agency, nonprofit organization, or other entity contracted to conduct business on behalf of a participating agency provided that they are required to follow state and local procurement regulations.

Prompt Payment: Participating Agencies will follow M.S. §471.425 regarding prompt payment of local government bills.

Substance Use and Conduct: All Vendor partners and subcontractors must adhere to local substance (alcohol, drug, smoking, etc.) and conduct (dress code, language, parking, etc.) policies while on a participating agencies' premises.

Vendor Orientation (CPC 101): The Vendor and their participating resellers/sub-contractors will be required to participate in an online training session that is designed to educate the Vendor and resellers/sub-contractors on the

purpose and nature of CPC. The Vendor will not be marketed to participating agencies until they have completed the vendor orientation session.

2. Additional Participating Agency Terms and Conditions for Non-Construction Products and Services

If requested by CPC, the contracted vendor will work with CPC to develop an order form, or order forms, containing the most commonly purchased items, that CPC can utilize to market the contracted vendor to its participating agencies.

3. Additional Participating Agency Terms and Conditions for Construction Related Products and Services

Upon acceptance and approval of the Vendor's offer by AEPA, CPC will independently consider the offer and conduct a conference call with the Vendor to determine if the Vendor is able to meet the necessary requirements for construction related products and services and to enter and execute a contract in the state of Minnesota. The contracted vendor will be required to work with CPC's participating agencies and require that an architect's signature or certification is noted on the specifications as required by **Minnesota Statute §326.12 subd. 3**. With certain exceptions, **Minnesota Rules part 1800.5200, subpart 1**, requires a licensed architect or engineer to prepare and certify specifications for building alterations or renovations. Once CPC and the Vendor are able to confirm that business is able to be conducted in Minnesota, CPC will make a final decision to complete the contract execution process.

For all quotes provided to participating agencies, for construction related projects, products and services, the contracted vendor must also send a duplicate quote to CPC. The quote provided to CPC must include the contact information of the participating agency.

Performance Bond (for construction and/or installation related projects): Performance bonds will be required on all projects valued at fifty-thousand dollars (\$50,000) or more in Minnesota and North Dakota and, twenty-five thousand dollars (\$25,000) or more in South Dakota. All performance bonds will be issued by a corporate surety authorized to do business in the state in which the work will be conducted and by a surety listed in the US Treasury Circular 570. Performance bonds will be posted by the Vendor and submitted to the specific participating agency for the assigned project. Should the contract be the result of a piggyback agreement, performance bonds will reflect each state's bonding requirements.

The Vendor will execute a performance bond in an amount equal to one hundred percent (100%) of the value specified in the contract between the participating agency and the Vendor, unless the participating agency requires less to be posted. This bond will protect all persons supplying labor and material to the Vendor for the performance of the work provided in the contract. Subcontractors who may work on the contract may have to provide the Vendor with a performance bond. If the contract price increases after the bond is provided, the participating agency may consider obtaining additional bonds from the Vendor.

The Vendor will deliver the performance bond to the eligible participating agency at the time the contract is executed between the agency and the Vendor. Work will not commence between the Vendor and the eligible participating agency until the performance bond is received by the participating agency and a copy has been sent to CPC via email (info@purchasingconnection.org). The Vendor will be responsible for providing CPC with a copy of all contracts and bonds in accordance with CPC purchasing procedures. Should the Vendor fail to satisfactorily perform the contract, the bonding company that provided the performance bond will be required to pay the dollar amount of the bond to the participating agency.

It is the Vendor's responsibility to ensure that they can obtain the required bonding for all construction products based on an awarded contract arising from this solicitation. Payment will not be issued for any project for which the required bonds have not been received.

4. Procedure for Contract Award, Notification and Processing Orders

Once the award is recommended by the AEPA Review Committee, CPC considers the recommendation based on the value of the potential contract for its participating agencies. Participating agency is defined as any city, county, public or private educational agency, nonprofit or governmental agency that is a participant of CPC. In the event of an award by the Board of Directors, CPC will inform its members of the award and contract by the following methods

along with contract instructions and ordering process.

- a. The contract is listed and promoted on the CPC website (www.purchasingconnection.org).
- b. Announcing the award in CPC newsletters.
- c. CPC will publish the contract and marketing information through a hard copy marketing flier and electronic email. Contracts are promoted through PDF and a hard copy product catalog distributed at statewide trade shows and agency meetings on a regular basis. CPC will require a marketing flier, brochure, or other similar marketing pieces, in an editable, electronic format, from each vendor promoting the available contract with the vendor, and/or a web page or link. CPC may assist in the development of the marketing flier and material (if requested by vendor), but in all cases shall have authority to review and approve any marketing materials. If a web site is used, the link will be made available from the CPC web page. Any web page or link, or other marketing tool shall be dedicated to AEPA information only.
- d. When the member identifies a desired product or service, the member and the vendor may negotiate with each other to establish a description of items and/or services. The vendor shall quote a price to the member, in writing, using AEPA established discounts and including the two percent (2%) administrative fee in the quoted price. The administrative fee shall be based upon the total cost of goods and/or services including installation costs. The administrative fee shall not be listed as a separate line item on the quote. When a member decides to purchase through the CPC-AEPA contract, the member issues the purchase order directly to the vendor. The purchase order must include the total invoiced cost, based on
 - i. The total cost of goods, service, and installation, including the 2% administrative fee.
 - ii. Notification will be made to the vendor in the event the purchase order is not in compliance with the contract and adjustments will be made at that time. CPC and the vendor will mutually resolve any issues with regard to past purchases. The purchase orders are to continue to be processed and viewed as approved unless notified by CPC otherwise. All sales and transactions may continue without delay or in anticipation of the CPC purchase order verification.
 - iii. Once all the items and services on the purchase order have been delivered to the member in a complete and satisfactory manner, the vendor then files a copy of the final invoice, which is available to CPC by request in support of the quarterly sales summary. The invoice is to be marked "Copy".
 - iv. Vendor makes all deliveries and installations of products and services. CPC does not warehouse items or provide installation services.
 - v. This administrative fee is to be paid by the vendor to CPC, quarterly, within 20 working days after the end of each fiscal quarter. The AEPA vendor shall also submit to CPC a sales report, in Excel format, listing the following information:
 1. Name of purchasing agency
 2. Address of purchasing agency
 3. Date of purchase
 4. Invoice number
 5. Amount of purchase
 6. Administrative fee generated by sale
 7. Savings generated by sale
 8. This report shall include all sales made and payments received by the vendor in said quarter. The sales report shall be emailed to Melissa Mattson at mmattson@lcsc.org and copied to Lori Mittelstadt at lmittelstadt@lcsc.org. The administrative fee payment shall be delivered to Melissa Mattson, CPC, 1001 East Mt. Faith, Fergus Falls, MN 56537. The check shall be made out to Lakes Country Service Cooperative.
 - vi. CPC requires that all participating vendors offer the contract opportunity to all CPC participating agencies.
5. **Express Online Marketplace:** CPC provides participating agencies with an online purchasing platform called Express, powered by EqualLevel. Through Express, agencies are able to search for and purchase items. Essentially, Express is a one-stop shop for many of CPC's commodity based contracts. A Vendor does not have to have an e-commerce site to be included in Express. Express offers integration into two (2) of the main K-12 school financial systems in Minnesota, CPC expects growth in the number of agencies utilizing the marketplace and the volume of sales to grow significantly. CPC will work with the Vendor to determine if the contract agreement is suitable for the online platform. If deemed suitable, CPC will require integration into Express within a timely manner.

14. Missouri, Cooperating School Districts of the Greater St. Louis Area, (CSD)

A. Additional Agency Terms and Conditions

Lease and Rentals: Vendor may allow EDPLUS members to enter into rental, lease, or lease purchase agreements, providing such agreements are in compliance with Missouri statutes and State Department of Education policies, rules and regulations. EDPLUS must receive a copy of the executed leasing documents prior to processing a purchase order. EDPLUS will not collect lease payments. Bidder agrees that leases will be in compliance with the Uniform Commercial Code. All terms of leasing must be included in the proposal, with interest rates described as related to a government standard. Bidder must indicate in its response to this solicitation if the shipping costs for the return of leased or rented equipment are the responsibility of the EDPLUS member, and what that cost will be. No sale of a contract to a third party will be made without first informing EDPLUS and the EDPLUS member of the sale. If Bidder sells a lease contract to a third party, the cost of return must not be greater than the cost of return to the original vendor. A 2% administrative fee must be included in the lease cost based on the total value of the goods purchased. This fee is referred to under ordering process.

B. Procedure for Processing Orders

(1.) Once the award is made to the vendor, EDPLUS will inform its members (and non-members eligible to purchase from EDPLUS) of the contract by announcing the award in its periodic newsletter and other EDPLUS presentations as well as regular electronic communications.

(2.) EDPLUS may require a marketing flier from each vendor promoting the contract and AEPA relationship. EDPLUS will assist in the development of the marketing flier and material. This flier will be for distribution as well as posting on the EDPLUS website and disseminated to potential customers. Note: EDPLUS requires the awarded vendor to take ownership and actively promote the contract in cooperation with EDPLUS to all qualified customers.

(3.) When the member identifies a desired product or service as available through the AEPA contract and makes a purchase on the EDPLUS online Marketplace or agrees on price as presented to the member by the awarded AEPA vendor, the member then issues to the vendor a purchase order for that item or service.

(4.) The purchase order must include an additional two percent (2%) administrative fee in the total cost, based on the total cost of goods and service including installation and freight if applicable. This fee is to be forwarded by the vendor to EDPLUS after the sale and payment is made to vendor. Payment shall be made to EDPLUS on a quarterly basis along with complete sales history during that period.

(5.) Vendor makes all deliveries and installations of products and services. EDPLUS does not warehouse items nor provide services.

(6.) All participating vendors agree to and are subject to audit proceedings of AEPA member sales.

C. Members Purchasing Under the Agency

We take great pride in the fact that EducationPlus is providing a complete line of purchasing services to our 50+ member school districts and hundreds of additional school districts, educational institutions, and nonprofit organizations throughout Missouri and Illinois. EducationPlus was created in 1928 with its primary focus aimed at improving educational opportunities for all students. Our goal is to promote efficient use of educational dollars, and simultaneously provide an ongoing market for those vendors doing business with EducationPlus. EducationPlus serves schools and political subdivisions in Missouri and Illinois.

D. Governing Law

MO. REV. STAT. §70.220. 1. Any municipality or political subdivision of this state, as herein defined, may contract and cooperate with any other municipality or political subdivision, or with an elective or appointive official thereof, or with a duly authorized agency of the United States, or of this state, or with other states or their municipalities or political subdivisions, or with any private person, firm, association or corporation, for the planning, development, construction, acquisition or operation of any public improvement or facility, or for a common service; provided, that the subject and purposes of any such contract or cooperative action made and entered into by such municipality or political subdivision shall be within the scope of the powers of such municipality or political subdivision.

15. **Montana, Montana Cooperative Services (MCS)**

General Standards: Purchases by public entities in excess of \$80,000 are subject to public bid; purchases under this amount are subject to requirements of public contracts. See Sections 7-5-2301 and 7-5-2304, Montana Code Annotated (Counties); Sections 7-5-4302 and 7-5-4303, Montana Code Annotated (Municipalities).

Note: purchases of less than \$80,000 are not subject to public bid requirements, which provides local government entities with considerable flexibility to make purchases. Public bidding requirements do not appear to prohibit local government entities who are members of AEPA or MCS from soliciting bids from approved vendors for purchases in excess of \$80,000.

Local Government Cooperative Purchasing Authority: Local governments may also elect to purchase cooperatively through the Montana Department of Administration in lieu of soliciting their own bids. 51 A.G. Op. 15 (2006). Procurement by government entities generally falls within the Montana Procurement Act, Section 18-4-101, MCA, et seq.

Local Governments are authorized to adopt and implement the rules and standards of the Act:

18-4-124. Local government adoption of procurement provisions -- alternative project delivery contracts. (1) A political subdivision or school district may adopt any or all parts of this chapter and the accompanying rules promulgated by the department.

Local governmental entities and school districts are specifically authorized to purchase cooperatively in the public interest:

18-4-401. Definitions. As used in this part, the following definitions apply:

(1) "Cooperative purchasing" means procurement conducted by or on behalf of more than one public procurement unit.

"Local public procurement unit" means a county, city, town, or other subdivision of the state or a public agency of any such subdivision; public authority; educational, health, or other institution; to the extent provided by law, any other entity that expends public funds for the procurement of supplies and services; and any nonprofit corporation operating a charitable hospital.

"Public procurement unit" means a local or state public procurement unit of this or any other state, including an agency of the United States, or a tribal procurement unit.

"State public procurement unit" means a state department, agency, or official that expends public funds for the procurement of supplies and services.

"Tribal procurement unit" means a tribal government, tribal entity, or official of a tribal government located in Montana that expends tribal funds or funds administered by a tribe for the procurement of supplies and services to the extent provided by tribal or federal law.

18-4-402. Cooperative purchasing authorized. The department may participate in, sponsor, conduct, or administer a cooperative purchasing agreement for the procurement of any supplies or services with one or more public procurement units in accordance with an agreement entered into between the participants independent of the requirements of part 3. Cooperative purchasing may include purchasing through federal supply schedules of the United States general services administration, joint or multiparty contracts

between public procurement units, open-ended state public procurement unit contracts that are made available to local public procurement units, and competitive contracts established by for-profit, not-for-profit, or nonprofit cooperative entities. (emphasis added).

Note: Cooperative purchasing by local governmental entities may require entering into an agreement with the Montana Department of Administration. This requirement does not appear to preclude local entities from participating as members of purchasing groups.

Local governmental entities are authorized to enter agreements with each other in order to purchase cooperatively.

7-11-104. Authorization to create interlocal agreements -- issuance of bonds for joint construction -- hiring of teacher, specialist, or superintendent. One or more public agencies may contract with any one or more other public agencies to perform any administrative service, activity, or undertaking or to participate in the provision or maintenance of any public infrastructure facility, project, or service, including the issuance of bonds for the joint construction of a facility under 20-9-404, the hiring of a teacher or specialist under 20-4-201 or a superintendent under 20-4-401, or the hiring of or contracting with any other professional person licensed under Title 37, that any of the public agencies entering into the contract is authorized by law to perform. The contract must be authorized and approved by the governing body of each party to the contract. The contract must outline fully the purposes, powers, rights, obligations, and responsibilities of the contracting parties. (emphasis added).

School and school district cooperative purchasing authority: Schools and school districts are specifically authorized to purchase cooperatively utilizing qualifying purchasing entities:

"A [school] district may enter into a cooperative purchasing contract for the procurement of supplies or services with one or more districts. A district participating in a cooperative purchasing group may purchase supplies and services through the group without complying with the provisions of [soliciting public bids and awarding a contract] if the cooperative purchasing group has a publicly available master list of items available with pricing included and provides an opportunity at least twice yearly for any vendor, including a Montana vendor, to compete, based on a lowest responsible bidder standard, for inclusion of the vendor's supplies and services on the cooperative purchasing group's master list." Section 20-9-204(4), Montana Code Annotated (emphasis added).

Note: Montana's AEPA member, Montana Cooperative Services, meets all of the statutory requirements of Section 20-9-204(4), MCA, with respect to cooperative purchasing groups.

Cooperative purchasing is another tool in the bag for local governmental entities, including school districts, to acquire services and supplies at better prices than may otherwise be available. Membership in MCS provides access to AEPA-approved vendors as well as in-state suppliers who have been carefully vetted for reliability and quality.

Disclaimer: The above discussion is for informational purposes only and does not constitute legal advice.

16. Nebraska, Educational Service Unit Coordinating Council (ESUCC)

A. Additional Agency Terms and Conditions

1) Bid Award Determination: The bidder hereby agrees to these bidding conditions by virtue of submitting this signed document on or before the Bid Opening date as specified below.

2) Natural Gas Contractors: Any bids relating to natural gas shall be based upon an awareness of NEB. REV. STAT. § 75-501, adopted in conformity with Rules, Regulations, and Interpretations of Federal Agencies with authority to regulate pipeline common carriers and interstate commerce.

3) Performance and Payment Bonds: Upon execution of a contract between an ESUCC member and the prime contractor for construction or public improvement, performance and payment bonds described above in the AEPA General Terms and Condition shall be provided to the member. Performance and payment bonds between the member and the prime contractor shall be on standard forms. The prime contractor shall deliver copies of both the performance and payment bonds to ESUCC at the time the contract between the member and the prime contractor is executed. All suits for nonpayment or nonperformance shall be filed as allowed under Nebraska law.

4) Insurance: Contractors shall secure and keep in force during the term of any awarded agreement the following insurance coverages from insurance companies authorized to do business in Nebraska:

- Commercial general liability, including premises or operations, contractual, and products or completed operations coverages (if applicable), with minimum liability limits of \$1,000,000 per person for any number of claims arising out of a single occurrence and \$5,000,000 for all claims arising out of a single occurrence.
- Automobile liability, including Owned (if any), Hired, and Non-Owned automobiles, with minimum liability limits of \$1,000,000 per person for any number of claims arising out of a single occurrence and \$5,000,000 for all claims arising out of a single occurrence.
- Workers compensation coverage meeting all statutory requirements.

5) Debarment and Suspension: Contractors shall comply with Executive Orders 12549 and 12689 as applicable. Contractors may be debarred for a period of two (2) years, unless earlier modified by the Special Awards Committee of ESUCC for any of the following conduct: (a.) Repeatedly not following the bid process. (b.) Repeatedly submitting non-responsive bids. (c.) Any behavior, which has as its effect injuring the integrity of the bid process. (d.) Failure to deliver goods pursuant to a successful bid. (e.) Repeated lack of acceptable handling and delivery of goods pursuant to a successful bid. (f.) Repeatedly not meeting delivery deadlines. (g.) Repeated failure to timely rectify damages of goods, or shortages of goods when it is the responsibility of the contractor to take such action. (h.) Conviction of a crime of dishonesty. (i.) Debarment or suspension by any agency or Federal Agency by the contractor or any of its key employees. (j.) Other conducts which materially and adversely affects the services of ESUCC Cooperative Purchasing program.

6) Statement Filed: A bidder who is awarded a contract for any goods or services pursuant to this IFB shall file with ESUCC a statement as required by NEB. REV. STAT. § 73-102.

7) Nondiscrimination: The Contractor and all subcontractors, if any, shall not discriminate against any employee or applicant who is to be employed for performance of any awarded bid or agreement with respect to his or her hire, tenure, terms, conditions, or privileges of employment, because of his race, color, religion, sex, disability, or national origin.

8) Employment Eligibility Verification: The Contractor shall use a federal immigration verification system to determine the work eligibility status of employees hired on or after October 1, 2009 and who are physically performing services within the State of Nebraska. If the Contractor employs or contracts with any subcontractor in connection with any awarded bid or agreement, the Contractor shall include a provision in the contract requiring the subcontractor to use a federal immigration verification system to determine the work eligibility status of new employees physically performing services within the State of Nebraska.

9) Federal Funding. It is understood that purchases may be funded in whole or in part with funds allocated by the Federal government, including the U.S. Department of Education and is therefore subject to those regulations, restrictions, and conditions normally associated with federally funded programs and any other requirements that the state or federal government may prescribe including, but not necessarily limited to, the "Federal Requirements" listed above in the AEPA Terms and Conditions and the following:

- **Lobbying:** The Bidder agrees and understands that under the Byrd Anti-Lobbying Amendment (31 U.S.C. 1352) that Bidders that apply or bid for an award of \$100,000 or more must file the required certification. Each tier certifies to the tier above that it will not and has not used Federal appropriated funds to pay any person or organization for influencing or attempting to influence an officer or employee of any agency, a member of Congress, officer or employee of Congress, or an employee of a member of Congress in connection with obtaining any Federal contract, grant or any other award covered by 31 U.S.C. 1352.
- **Patent Rights:** The USDOE's and any other federal agency's requirements and regulations pertaining to patent rights with respect to any discovery or invention which arises or is developed in the course or under this Agreement include, but are not necessarily limited to, 34 CFR Part 80.
- **Copyrights and Right in Data:** The USDOE's and any other federal agency's requirements and regulations pertaining to copyrights and rights in data include, but are not necessarily limited to, 34 CFR Part 80.
- **Access to Documents:** The Parties and their grantees, the USDOE and/or other federal grantor agency, the Comptroller General of the United States, or any of their duly authorized representatives shall have access

to any books, documents, papers, and records of the Bidder which are directly pertinent to this Agreement for the purpose of making audit, examination, excerpts, and transcriptions.

- **Energy Policy and Conservation Act:** The parties shall comply with the mandatory standards and policies relating to energy efficiency which are contained in the state energy conservation plan issued in compliance with the Energy Policy and Conservation Act (42 U.S.C. 6201).
-
- **Buy American:** To the maximum extent practicable, the Bidder will purchase domestic commodities or products produced in the United States or processed substantially using commodities produced in the United States
- **Minority Business Owners:** The ESUCC will contract with minority-owned businesses, women's business enterprises, and labor surplus firms when possible. Steps to ensure compliance with this provision will include:
 - .1 Qualified small, minority, and women's businesses on solicitation lists so that when such businesses are potential vendors, they are included in ESUCC solicitations.
 - .2 Dividing total requirements, when economically feasible, into smaller tasks or quantities to permit maximum participation for such businesses.
 - .3 Establishing delivery schedules, where requirement permits, which encourage such enterprises
 - .4 Use services of Small Business Administration, Minority Development Agency, or similar state agency to maximize participation.
 - .5 Require prime Bidder, if subcontracts are to be let, to follow the above steps

11) Governing Law and Venue: All bids and contracts shall be governed by and construed in accordance with the laws of the State of Nebraska. The venue for any litigation arising out of or related to a bid or contract will be in any eligible state or federal court of Nebraska.

12) Public Records: The Contractor acknowledges that the ESUCC and its affiliated schools and members must comply with NEB. REV. STAT. § 84-712 through § 84-713 and release public records as defined law upon request, which may include any bid documents or contracts and all records created and maintained in relation to them.

13) Conflict of Interest: By submitting a proposal, Contractor certifies that there does not now exist any relationship between the Contractor and any person or entity which is or gives the appearance of a conflict of interest related to this Request for Proposal. The Bidder certifies that it shall not take any action or acquire any interest, either directly or indirectly, which will conflict in any manner or degree with the performance of its services hereunder or which creates an actual or appearance of conflict of interest. The Bidder certifies that it will not employ any individual known by Bidder to have a conflict of interest.

The Contractor shall not, at any time, recruit or employ any employee or agent who has worked on the Request for Proposal or project, or who had any influence on decisions affecting the Request for Proposal or project.

The submission of the offer did not involve collusion or other anti-competitive practices. Neither signatory nor any person on his behalf, has not agreed, connived or colluded to produce a deceptive show of competition in the matter of the bidding or award of a contract under this solicitation.

The Contractor, by submitting a bid, certifies that it has not had a contract with education organizations in State of Nebraska terminated early. If Contractor has had a contract terminated early within the State of Nebraska, Contractor must provide the contract number, along with an explanation of why the contract was terminated early.

Contractor has not given, offered to give, nor intends to give at any time hereafter any economic opportunity, future employment, gift, loan, gratuity, special discount, trip, favor, or service to a public servant in connection with the submitted offer.

Contractor certifies that Contractor and Contractor's employees, officers, and associates directly involved in obtaining contracts with the State of Nebraska, ESUCC, or any subdivision of the state have not been convicted of false pretenses, attempted false pretenses, or conspiracy to commit false pretenses, bribery, attempted bribery or conspiracy to bribe under the laws of any state or federal government for acts or omissions after January 1, 1985

ESUCC may cancel any contract if it is found that gratuities in the form of entertainment, gifts or otherwise, were offered or given by Contractor or any agent or representative of Contractor, to any employee of ESUCC with a view toward securing a contract or with respect to the performance of this contract. Paying the expenses of normal business meals, which are generally made available to all eligible school and government employees, shall not be prohibited by this paragraph. Samples of software, equipment or hardware provided to ESUCC for demonstration or evaluation are not considered gratuities.

B. Procedure for Processing Orders

ESUCC affiliated schools or members send their purchase orders both directly and electronically to the vendor, the vendor ships directly to the school/member, and direct bills the schools/members the cost of merchandise plus the ESUCC 2% administrative fee. Vendors must provide a quarterly report to ESUCC Cooperative Purchasing. The report will include: Date of sales, school name, ESU affiliation, selling price, list price and savings. The ESUCC Cooperative Purchasing administrative Fee of 2% will accompany each quarterly report.

C. Members Purchasing Under the Agency

ESUCC represents 17 Educational Service Units statewide who in turn service Nebraska school districts with over 300,000 students. ESUCC is authorized to coordinate purchases for public school districts, nonpublic school systems, other ESUs, and

other public agencies, including any county, city, village, school district, or agency of the state government, any drainage district, sanitary and improvement district, or other Municipal Corporation or political subdivision of the State of Nebraska.

D. Procedure for Processing Orders

All purchase orders will be submitted directly from the purchasing entity to the vendor. ESUCC will not facilitate the processing of purchase orders unless the offering is service related. If it is a service related purchase then the purchase order shall be submitted by ESUCC.

E. Agencies Allowed to Purchase under the Member Agency

Purchases through ESUCC contracts are to be primarily for K-12. However other state entities may use the ESUCC contracts. All inquiries to purchase on the behalf of a non-profit group not in state statute or receiving state funding must be approved by ESUCC.

17. New Jersey, The Educational Services Commission of New Jersey (ESCNJ)

A. Additional Agency Terms and Conditions

Applicability of Contract Provisions to New Jersey Participants

ESCNJ is the AEPA Member Agency. Any entity that uses the contract awarded by ESCNJ under this document is referred to as a "New Jersey Participant." To be a New Jersey Participant the entity must be a member of the ESCNJ Cooperative Pricing System. The bidder that is awarded the contract by ESCNJ is referred to as the "Contractor."

Once a contract is awarded by ESCNJ, a New Jersey Participant may enter into a purchase order agreement directly with the Contractor. To the extent not otherwise described below or in this document, once a purchase order is issued by a New Jersey Participant to a Contractor, all of the provisions of the contract shall benefit and be enforceable by such New Jersey Participant, unless specifically identified as applying to ESCNJ only.

1. The Bidder by submitting its bid hereby declares that this Bid is made without any connection with any other person or person making any proposal for the same items, that it is in all respects fair and without collusion or fraud and that no person acting for or employed by ESCNJ or a New Jersey Participant is directly or indirectly interested in the proposal or in the goods or services to which it relates, or in any portion of the profits there from.

2. **Event of default and termination of Contract:**

ESCNJ shall have the right to cancel the contract based upon a default by Contractor. A New Jersey Participant shall have the right to cancel its purchase arrangement based on a default by the Contractor with regard to such purchase arrangement. In addition, ESCNJ and each New Jersey Participant reserves the right to withhold payments for goods and services that are not in compliance with the terms of the contract or if the Contractor is in default. Any of the following shall be a default under the contract: 1) The Contractor fails to adequately perform the services set forth in the contract; 2) Contractor fails to deliver all or any part of the goods, or delivers defective goods; 3) The Contractor fails to make progress in the performance of the contract and/or does not deliver within the agreed-upon schedules; 4) The Contractor fails to observe any of the terms and conditions of the contract, including, without limitation, assigning the contract and/or failing to deliver required insurance or performance bonds; 5) The Contractor fails to follow the established procedure for purchase orders, invoices and receipt of funds as stipulated by the New Jersey Participant; or 6) the Contractor has become insolvent, makes an assignment for the benefit of creditors, files a voluntary petition in bankruptcy or is subject to an involuntary petition in bankruptcy not discharged within thirty (30) days. ESCNJ and each New Jersey Participant shall follow the following procedure if the contract or purchase order is to be terminated:

Step 1 - Issue a warning letter of concern outlining the violations and length of time to correct the problem(s). The length of time to correct the problem shall be determined by ESCNJ or the New Jersey Participant, as applicable, in its sole discretion, based on the problem.

Step 2 - Issue a letter of intent to cancel the contract or purchase order, if the problem(s) is not resolved by the given date.

Step 3 - Issue the letter to cancel contract or purchase order.

Upon receipt of the written notice of concern, the Contractor shall have ten (10) business days to provide a satisfactory response to ESCNJ and the New Jersey Participant that provided the notices. Failure on the part of the Contractor to address adequately all issues or concerns may result in contract cancellation.

The remedy to terminate and withhold payments is in addition to any other remedies ESCNJ and the New Jersey Participants may have. In the event of Contract termination by a New Jersey Participant, such New Jersey Participant's payment obligation shall cease as of the final date on which services in accordance with this Contract are last performed by the Contractor. Upon termination of this Contract under this section, the Contractor (and its surety) will be responsible for all of such New Jersey Participant's expenses, losses and damages incurred in replacing Contractor for the remainder of the term of the Contract.

3. **Assignment:**

Contractor shall not subcontract, assign, transfer, convey, sublet or otherwise dispose of its/his/her contractual duties to any other person, firm, or corporation, without the previous written consent of ESCNJ and any New Jersey Participant that has an outstanding open purchase order or financing arrangement. If the Contractor wants to assign its/his/her right to payment of the Contract, Contractor shall notify ESCNJ and any New Jersey Participant that has an outstanding open purchase order or financing arrangement immediately, in writing, of such assignment of right to payment. In no case shall such assignment of Contract relieve the Contractor from its/his/her obligations or change the terms of the Contract.

4. Indemnification:

Contractor shall indemnify, defend, keep and save harmless ESCNJ, each New Jersey Participant and its respective agents, officials, employees and volunteers (each an "Indemnified Party") against claims of injuries, death, damage to property, patent claims, suits, liabilities, judgments, cost and expenses (including attorneys' fees) which result from, arise out of, or in connection with the performance, or breach of performance, under the Contract of Contractor and any of its/his/her employees, agents or personnel. The Contractor shall, at its/his/her own expense, appear, defend and pay all charges of attorneys and all costs and other expenses arising there from or incurred in connection therewith; and if any judgment shall be rendered against the Indemnified Party in any such action, the Contractor shall, at its/his/her own expense, satisfy and discharge the same. Contractor expressly understands and agrees that any performance bond or insurance protection required by this contract, or otherwise provided by the Contractor, shall in no way limit the responsibility to indemnify, keep and save harmless and defend the Indemnified Party as herein provided.

5. New Jersey Participant Policies:

The Contractor must be familiar with a New Jersey Participant's policies or regulations which affect the services provided under this Contract and that have been or will be distributed during the term of this Contract. Policies and regulations include, but are not limited to, New Jersey Public Contracts Law, school district policies, municipality policies, charters school policies, and county ordinances.

As each board of education, municipality governmental agency, educational institution in the State of New Jersey may have or may be required to have individual policies and procedures for the procurement of goods and services; and as one of the aforementioned institutions/agencies may be dependent upon the policies/procedures of another institution or agency, it is required for the Contractor to be familiar with the policies of the New Jersey Participant that impact the purchase. In limited situations, there may be State statutes which govern the allowability of purchases to be reimbursed by State funding. The New Jersey Participant should obtain its own legal advice on these statutes prior to purchasing under a contract.

The following documentation will be required prior to the award of any contract for New Jersey Participants:

1. New Jersey Business Registration Certificate - Before award in NJ, not at time of bid
2. New Jersey Contractors Registration Certificate (All time and material bids.) Before award in NJ not at time of bid
3. New Jersey Pay-to-Play Documentation (Political Contribution Disclosure)
4. Statement of Ownership (Ownership Declaration Certification)
5. New Jersey Affirmative Language (Exhibit A) and (Exhibit B) for construction repair and maintenance contracts
6. Acknowledgement of the Contractor's/Vendor's responsibility to pay prevailing wage.
http://lwd.dol.state.nj.us/labor/wagehour/wagerate/prevailing_wage_determinations.html
(Time and material bids.)
7. New Jersey Affirmative Action Questionnaire/Documentation
8. Disclosure of Investment Activities in Iran
9. Years of experience is not a criteria for the evaluation of bids to be awarded for the State of New Jersey. For additional information visit www.nj.gov/dca/divisions/dlgs
10. W9
11. Certificate of Insurance with the ESCNJ named as insured and the bid title/# listed - Before award in NJ, not at time of bid
12. DPMC - (All time and material bids.) Before award in NJ, not at time of bid
13. Total Amount of Uncompleted Contracts (All time and material bids.) Before award in NJ, not at time of bid
14. Americans with Disabilities ACT of 1990
15. Attachment B - New Jersey Anti-discrimination Provisions
16. Statement of Suspension or Debarment Form
17. Sworn Contractor Certification; Qualifications Credentials
18. Subcontractor Disclosure Statement
19. Prevailing Wages Certification—Submission with Bid_

6. Performance Bonds:

Each New Jersey Participant may require a performance bond in the case of services to be performed under the Contract if required. The Contractor shall furnish to the New Jersey Participant a Surety Performance Bond ("Performance Bond") with an option to renew each succeeding year of the Contract in a form satisfactory to the New Jersey Participant assuring the faithful performance of the Contract. The Bond shall be equal to one hundred percent (100%) of each year's estimated Contract price as reviewed and agreed upon by the New Jersey Participant, and shall be continued for the life of the Contract in amounts equal to one hundred percent (100%) of each year's estimated Contract price as reviewed and

agreed upon by the New Jersey Participant. The Contractor must send such Performance Bond to the New Jersey Participant prior to the commencement of any services under the Contract. Each such Performance Bond shall be furnished by a surety company acceptable to the New Jersey Participant and licensed or authorized to do business in New Jersey. Failure to deliver the bond shall be considered a default under the Contract, at the discretion of and upon notice by the New Jersey Participant.

7. Governing Law:

This Contract shall be governed by, and construed and enforced in accordance with, the laws of the State of New Jersey without regard to its conflicts of laws principles.

8. Financing Arrangements:

Any financing arrangements (including lease purchasing arrangements) may be made directly between the Contractor and a New Jersey Participant or with the free ESCNJ Leasing Program. Financing arrangements may be subject to additional laws, rules and regulations, terms and conditions not described in this document and are subject to separate negotiation with each New Jersey Participant that is interested in such an arrangement. Each New Jersey Participant should seek its own legal advice prior to entering into a financing arrangement. ESCNJ must receive a report annually summarizing the executed lease purchases along with the summary of the customer purchases. ESCNJ will not collect lease payments or be involved in the terms and conditions of the Contractor lease. All lease arrangements are between the Contractor and the New Jersey Participant only.

9. Affirmative Action:

The Contractor/Vendor must have an employment policy that there shall be no discrimination against anyone on the grounds of race, color, religious creed, age, marital status, national origin, ancestry, sex, mental retardation, physical disability or sexual orientation in the hiring, upgrading, demotions, recruitment, termination and selections for training, in any manner prohibited by the laws of the United States or of the State of New Jersey. The Contractor/Vendor further agrees to be an "affirmative action-equal opportunity employer." The Contractor/Vendor must provide one of the following: "Letter of Federal Affirmative Action Plan Approval", "Certificate of Employee Information Report" or a completed "Employee Information Report Form AA302" prior to award bid.

10. Independent Contractor:

The Contractor shall not be held or deemed in any way to be the agent or employee of ESCNJ and/or a New Jersey Participant. It is the intention of the parties that the Contractor shall be and is to be considered an independent contractor.

11. Incorporation of Bid Documents:

The bid documents, including all appendices executed by Contractor that have been accepted by ESCNJ (the "Bid") are specifically incorporated into this Contract.

12. New Jersey Public Records Act:

The Contractor acknowledges that ESCNJ and New Jersey Participants are subject to the New Jersey Public Records Act, New Jersey Public Contracts Law and information submitted to ESCNJ and/or such New Jersey Participants may be made available to the public under the provisions of the this Act.

Marketing and Advertising under this Contract - applicable to Member Agency (ESCNJ) contract only:

1. Contractor agrees to provide ESCNJ with a copy or proof sheet of all advertisements, customer communications or promotional material for approval. Contractor will provide ESCNJ with date of release and name of publication, journal, etc. if applicable.
2. Contractor will include the approved ESCNJ logo, web address, bid #, bid title, bid term, NJ State Approved Co-op #65MCESCCPS and contact information in all print, electronic mail and other advertising and promotion intended for release in New Jersey.
3. The ESCNJ logo and information shall be of a clearly readable size and in appropriate proportion to other elements in the print material.
4. Contractor agrees to make available ESCNJ supplied brochures or other promotional materials on booths, tables, etc. of any or all exhibits for which the Contractor displays/participates at tradeshow, conventions and the like. Contractor will supply scheduled exhibit dates in advance.
5. Contractor agrees to insert the approved ESCNJ logo, web address, NJ State Approved Co-op #65MCESCCPS bid #, bid term and contact information on the Contractor's website promoting and providing a link to the ESCNJ website. Contractor will also provide ESCNJ with text, links and logos to be posted on the ESCNJ website.

B. Procedures for Processing Orders

1. Once the award is made to the Contractor, ESCNJ will inform the potential New Jersey Participants of the Contract, including a webpage dedicated to the contract on the ESCNJ website. At this point, the Contractor may directly contact

- any potential New Jersey Participant and any potential New Jersey Participant may directly contact the Contractor.
2. Purchase orders will not be accepted or processed by ESCNJ. All business will be contracted directly with the New Jersey Participant, which will issue a purchase order and provide payment for the applicable good or service directly to the Contractor.
 3. The total cost of ESCNJ's program is funded through a 2.2% participation fee paid to ESCNJ quarterly by the participating Contractors. The administrative fee percentage is based upon the total sale or lease of goods and services, including installation, if included. This fee shall be included in all price quotations to New Jersey Participants and shall not be printed as a line item on the quotation.
 4. Along with the participation fee, the Contractor will produce and provide to ESCNJ quarterly reports ending March 31, June 30, September 30 and December 31 throughout the contract period. The reports shall be in Microsoft Excel and be available in electronic form, shall identify the Contractor and the quarter being reported, shall be delivered to ESCNJ on the 15th of the month, shall include a minimum of the fields listed below and shall allow for sorting on any of these fields:
 1. Date of order.
 2. The name of the New Jersey Participant.
 3. ESCNJ Bid Number
 4. ESCNJ Co-op Number (New Jersey State Approved Cooperative Pricing System #65MCECCPS)
 5. List (or academic) price sales totals.
 6. New Jersey Participant price sales totals.
 7. New Jersey Participant savings totals to be sent to the ESCNJ in summary and to each individual New Jersey Participant.
 5. Quarterly reports and administrative fee payments are to be made payable to ESCNJ and sent to ESCNJ, 1660 Stelton Road, Piscataway, NJ 08854, Attn: Patrick M. Moran, or such other address that ESCNJ will provide from time to time.
 6. If no purchases are made in any given quarter, the Contractor shall remit a "No Activities" statement to ESCNJ for that quarter. The Contractor will also produce and provide to ESCNJ an annual summary report for all purchases made under each contract awarded by ESCNJ pursuant to this document for a period beginning with the award of the contract and ending December 31 and all consecutive annual periods, if the contract is extended.
 7. New Jersey School Districts and other eligible New Jersey Participants are normally exempt from sales tax. The Contractor/Vendor should confirm this exemption and collect a tax-exempt letter from each New Jersey Participant.

C. Members Purchasing Under the Agency

There are 596 operating school districts in New Jersey and all are eligible for membership. No district is obligated to use these services. Additional New Jersey Participants may include other public educational institutions, public colleges or universities, community colleges, vocational or technical schools, municipal governments, and other governmental, quasi-governmental, or non-profit organizations. The ESCNJ Cooperative Pricing System currently has 1,250+ New Jersey Participants located in all 21 Counties of the State of New Jersey.

CONFLICT OF INTEREST

An ESCNJ employee (including independent contractors for purposes of this definition) placing an order or recommending a vendor must disclose any relationship with that vendor which would not be considered an "arms-length" or independent transaction. This disclosure must be made in writing to the Business Administrator and/or Chief Financial Officer for an evaluation. The Business Administrator and/or the Chief Financial Officer will respond to this disclosure in writing.

For a transaction to be considered "arms-length" or "independent", an ESCNJ employee should not be influenced, dependent upon, guided or controlled by a vendor into choosing that vendor, or item to purchase; nor should it appear to a third party that an ESCNJ employee made a purchasing decision which appears to be based upon a personal relationship between the ESCNJ employee and vendor.

The following are examples when a transaction is NOT considered arms-length or independent: (1) when there exists a personal relationship between an ESCNJ employee and a vendor, (2) when there exists the potential for a personal benefit to an ESCNJ employee, or (3) the parties to a business deal are dependent upon one another for "something" other than the purchase itself.

The Contractor shall disclose any relationship with an ESCNJ employee that would not be considered an "arms-length" or independent transaction, as described above. This disclosure must be made in writing to the Business Administrator and/or the Chief Financial Officer for an evaluation. The Business Administrator and/or the Chief Financial Officer will respond to this disclosure in writing.

In addition, the Contractor shall, if given a copy of the potential New Jersey Participant's conflict of interest policy, follow the process in that policy, or otherwise disclose to a potential New Jersey Participant any relationship that would not be considered an "arms-length" or independent transaction with that New Jersey Participant, as described above. This disclosure must be made in writing to the chief official (for example, the Superintendent at a board of education) at the potential New Jersey Participant.

Determination of the existence of a conflict of interest does not prohibit ESCNJ and/or a New Jersey Participant from entering into the contract and purchase order, respectively.

American Goods - American Goods Clause—N.J.S.A. 18A:18A-20 - American goods and products to be used where possible

All contracts for work for which it will pay any part of the cost or work which by contract it will ultimately own and maintain, that only manufactured and farm products of the United States, wherever available, to be used in such work.

Anti-discrimination - All parties to any contract with the ESCNJ agree not to discriminate in employment and agree to abide by all anti-discrimination laws including those contained within N.J.S.A. 10:2-1 through N.J.S.A. 10:2-4, N.J.S.A. 10:5-1 et seq. and N.J.S.A. 10:5-31 through 10:5-38, and all rules and regulations issued thereunder are hereby incorporated by reference.

Debarment/Suspension - N.J.A.C. 17:19-1.1 et seq. The ESCNJ will not enter into a contract for work with any person, company or firm that is on the State Department of Labor and Workforce Development; Prevailing Wage Debarment List, or the State of New Jersey Consolidated Debarment Report (www.state.nj.us/treasury/debarred) or the Federal System for Award—SA (www.state.nj.us/treasury/debarred) or the Federal System for Award—SA

For Time and Material bids - DPMC - There is a non-refundable fee of \$100.00 which must be submitted to the State with your application. All payments must be made on company checks (no-cash) made payable to "Treasurer, State of New Jersey". No application will be processed without the fee. If you have any questions, please contact the Contractor Classification unit by accessing the DPMC web site at www.state.nj.us/treasury/dpmc/ NOTE: It is suggested that a photocopy of this completed form be retained for your records. Please submit the completed application and all required documentation to the Treasurer, State of New Jersey. Upon review and approval of this application, your firm will be notified by mail of the effective and expiration dates, type of work, and rating assigned to your firm. Please submit your certificate with your bid package.

Any contractor who submits a bid for a public works contract the amount which exceeds **\$20,000**, pursuant to N.J.S.A. 18A:18A-26, 27 et seq., shall be classified by the Department of Treasury, Division of Property Management (DPMC) as to the type of work and trades (character) and the aggregate rating (amount) of public work they are qualified to submit bids.

The ESCNJ may only accept bids from contractors that are qualified.

Notice of Classification—DPMC-27

The Notice of Classification is a document issued by the DPMC that provides the following information about the qualified contractor:

- Trade(s) classification held by the contractor

The contractor is classified by the trade and trade number as found in Form DPMC-27. For example

Trade Number	Trade
C030	Plumbing
C032	HVACR

The contractor is therefore qualified to submit bids (exceeding \$20,000) to the board of education that pertain to plumbing and heating, ventilation, air conditioning and refrigeration.

For Time and Material bids Equipment Certification 18A:18A-23. A certificate showing that the bidder owns, leases, or controls all the necessary equipment required by the plans, specifications and advertisements under which bids are asked for and if the bidder is not the actual owner or lessee of any such equipment, his certificate shall state the source from which the equipment will be obtained, and shall be accompanied by a certificate from the owner or person in control of the equipment definitely granting to the bidder the control of the equipment required during such time as may be necessary for the completion of that portion of the contract for which it is necessary.

For Time and Material bids - Total Amount of Uncompleted Contracts - DPMC 701

This document is completed by the contractor submitting a bid, on the form provided by the DPMC. The document lists the amount of uncompleted contracts held by the contractor and a certification that the amount of uncompleted contracts, added to the bid amount for the ESCNJ Participant project, does not exceed the Aggregate Amount rating as assigned by the DPMC.

For Time and Material bids - Pre-qualification Affidavit/No Material Adverse Change

Pursuant to N.J.S.A. 18A:18A-32, no bidder is qualified to bid on any public work contract unless they provide an affidavit that there has been no material adverse change in his qualification information pursuant to N.J.S.A. 18A:18A-28.

For Time and Material bids - Prevailing wages; Alterations and repairs - The State of New Jersey Prevailing Wage Act, Chapter 150 Laws of 1963 with applicable statewide wage rates and for the wage rates for the county of the location of the New

Jersey Participant, as published by the Department of Labor and Workforce Development in conformance with N.J.S.A. 34:11-56-25 et seq. Copies of these wage rates may be obtained from the State Department of Labor and Workforce Development, and/or viewed at <http://lwd.dol.state.nj.us/> the Prevailing Wages Determination Section.

For Time and Material bids - Compliance with New Jersey Prevailing Wage Act

Every contractor and subcontractor performing services in connection with this project, shall pay all workers a wage rate not less than the published prevailing wage rates, for the locality the work is being performed, as designated by the New Jersey Department of Labor and Workforce Development.

For Time and Material bids - Certified Payrolls

Every contractor agrees to submit to the New Jersey Participant a certified payroll for each payroll period within ten (10) days of the payment of wages. The contractor further agrees that no payments will be made to the Contractor by the New Jersey Participant, if certified payrolls are not received by the New Jersey Participant. It is the Contractor's responsibility to insure timely receipt by the district of certified payrolls.

For Time and Material bids - Submission of Affidavit

Before final payment, the contractor shall furnish the New Jersey Participant with an affidavit stating that all workers have been paid the prevailing rate of wages in accordance with State of New Jersey requirements. The contractor shall keep an accurate record showing the name, craft, or trade and actual hourly rate of wages paid to each workman employed by him in connection with this work. Upon request, the Contractor(s) and each Subcontractor shall file written statements certifying to the amounts then due and owing to any and all workmen for wages due on account of the work. The statements shall be verified by the oaths of the Contractor or Subcontractor, as the case may be.

18. New Mexico, Cooperative Educational Services (CES)

Cooperative Educational Services (CES) is the administering agency of a Joint Powers Agreement as authorized by Section 11-1-1, et. seq. NMSA 1978, which is based in Albuquerque, New Mexico, and is composed of 180 New Mexico public educational institutions (Members) such as K-12 public school districts; charter schools; colleges and universities and their branch campuses; community colleges and vocational schools; Bureau of Indian Education (BIE) schools; that are parties to the Revised and Amended Joint Powers Agreement (JPA) to establish an educational cooperative. CES was organized in 1979 as a direct response to the needs of small and rural Local Education Agencies (LEA's). CES offers numerous programs and services in the following areas: administrative support, special education services, and cooperative purchasing.

A. CES General Terms and Conditions

Arbitration: This contract is subject to arbitration to the extent required by the New Mexico Procurement Code, 13-1-21 to 13-1-199. NMSA 1978.

Assignment of CES Payments: If the Contractor requests that its payment from CES/CES Members be issued to a third party or that a joint check be issued to the Contractor and a third party, this request must be submitted and approved by the agency prior to the Contractor accepting a purchase order. The agency reserves the right to assess a special handling charge of thirty-five dollars (\$35) per check. The special handling charge will be deducted from the amount of the invoice being paid. If the Contractor wishes to have all payments under this contract made to a third party, Contractor must state this in his response.

Background Checks - Per 22-10A-5 NMSA 1978, the New Mexico Public Education Department (NMPED) mandates security and background checks for individuals working and/or providing services within public school grounds and buildings. Specifically, part C of the sections states, "Local school boards and regional education cooperatives shall develop policies and procedures to require background checks on an applicant who has been offered employment, a Contractor or a Contractor's employee with unsupervised access to students at a public school." Describe how your company will comply with the CES Member's or Participating Entity's policies and procedures in regard to background checks.

CES Members: Are the parties to the CES Joint Powers Agreement (JPA) and consist of public educational institutions within the State of New Mexico and include public school districts as defined in NMSA 1978 § 22-1-2, State Institutions as defined in NMSA 1978 § 22-1-2, State Educational Institutions defined under Article XII, Section 11 of the New Mexico Constitution, most of the community colleges defined by the "Community College Act" as defined in NMSA 1978 § 21-13-1 et seq., their branch community colleges as defined in NMSA 1978 § 21-14-1 et seq., technical and vocational institutes defined in NMSA 1978 § 21-16-1, area vocational schools defined in NMSA 1978 § 21-17-4, off campus community colleges or instructional facilities as defined in NMSA 1978 § 21-14A-1, charter schools as defined in NMSA 1978 § 22-8A-1, Regional Center Cooperatives as set forth in Section 22-2B-1 et seq., and 638 schools and grant schools. Each public educational institution is authorized by its governing body and the Procurement Code 13-1-135 NMSA 1978 to enter into cooperative purchasing agreements, pursuant to Sec. 11-1-1 et seq. 1978 Comp. and Sec. 108 of Ch. 65 of the Laws of 1984 (The Procurement Code).

CES Participating Entities: Is defined as non-public educational agencies and/or organizations classified as follows, that may participate in and purchase tangible personal property, professional, non-professional and construction services through their cooperative purchasing agreement with CES.

1. Federal Agency [25 USC 3001 (4)] is defined as any department, agency, or instrument of the United States, any executive department, military department, government corporation, government-controlled corporation, or other establishment in the executive branch of government, including the Executive Office of the President or any independent regulatory agency established through legislative and/or administrative action.
2. State Agency [13-1-90 NMSA 1978] is defined as any department, commission, council, board, committee, institution, legislative body, agency, government corporation, educational institution or office of the executive, legislative or judicial branch of the government of this State. "State agency" includes the purchasing division

of the General Services Department (GSD) and the state purchasing agent but does not include local public bodies.

3. Local Public Body [13-1-67 NMSA 1978] is defined as a political subdivision of the State and the agencies, instruments and institutions thereof, including: two-year post-secondary educational institutions, school districts and local school boards and municipalities, except as exempted pursuant to the Procurement Code [13-1-28 NMSA 1978].
4. Non-Profit, Non-Public Educational Institutions and other Non-Profit Organizations (Section 501(c)(3) of the Internal Revenue Code, Federal Tax Code) is defined as charitable, religious, educational, public service, support and scientific organizations, entities, corporations that qualify as exempt organizations under Section 501(c)(3) of the Internal Revenue Code, or corresponding section of the Federal Tax Code.

CES Supplemental Packet: Upon acceptance and approval of the Contractor's offer by AEPA, CES will independently consider the offer and issue a Contractor's supplemental packet requesting specific information necessary to enter and execute a contract in the state of New Mexico including information relating to: the Contractor's qualifications; ability to conduct business in the state of New Mexico; and who will be coordinating, promoting, receiving, and processing orders; and providing the prime Contractor's goods and services in New Mexico. Once the prime Contractor provides this information, CES will review, seek clarification (if needed), and conduct a Contractor conference to complete the contract execution process.

CFR - Code of Federal Regulations www.gpoaccess.gov/cfr/index.html

Civil and Criminal Penalties: The New Mexico Procurement Code, Sections 13-1-21 through 13-1-199 NMSA 1978, imposes civil and criminal penalties for its violation. In addition, the New Mexico criminal statutes impose felony penalties for illegal bribes, gratuities and kickbacks.

Commencement Date/Substantial Completion Date: CES's purchase order establishes the Notice to Proceed. The Substantial Completion Date refers to a stage of a construction or building project or a designated portion of the project that is sufficiently complete, in accordance with the construction contract documents, so that the owner may use or occupy the building project or designated portion thereof for the intended purpose. The allowed duration for each project will be determined by the Contract Documents between the CES Agency and the Contractor.

Confidential Information and Disclosure of Proposal Contents: For the purposes of this procurement, the provisions of the "New Mexico Inspection of Public Records Act" (NMSA 1978, Chapter 14, Article 2) will be in effect. Pursuant to this Act, all proceedings, records, contracts, and other public documents relating to this procurement shall be open to public inspection. Proposers are reminded, that while trade secrets and other proprietary information they submit in conjunction with this procurement may not be subject to public disclosure, protections must be claimed by the proposer at the time of submission of its Technical Proposal. Proposers should refer to the New Mexico Inspection of Public Records Act for further clarification.

The designation of certain information as trade secrets and/or privileged or confidential proprietary information shall only apply to the technical portion of your proposal. Your cost proposal will not be considered confidential under any circumstance. Any proposal copyrighted or marked as confidential or proprietary in its entirety may be rejected without further consideration or recourse.

The Proposer must clearly designate the part of the proposal that contains a trade secret and/or privileged or confidential proprietary information as "confidential" in order to claim protection, if any, from disclosure. The proposer shall provide a sheet with the following legend, specifying the specific section(s) of his proposal sought to be restricted in accordance with the conditions of the legend:

"The data contained in pages ____ of the proposal have been submitted in confidence and contain trade secrets and/or privileged or confidential information and such data shall only be disclosed for evaluation purposes, provided that if a contract is awarded to this Proposer as a result of or in connection with the submission of this proposal, CES and its Members and Participating Entities shall have the right to use or disclose the data therein to the extent provided in the contract. This restriction does not limit CES and its Members and Participating Entities the right to use or disclose data obtained from any source, including the proposer, without restrictions."

Further, to protect such data, each page containing such data shall be specifically identified and marked "CONFIDENTIAL". Within the required electronic submission, any item marked as confidential will need to be submitted in a separate folder marked "Confidential information".

The CES Executive Director will review the statement and will determine in writing whether the information will be withheld. If the Executive Director determines that the information should be disclosed, the Contractor will be informed in writing of such determination. Contractor may object in writing within five (5) days after notification of determination, no disclosure will be made and the bid response may be rejected.

Contract Non-Exclusive: Any contract resulting from this solicitation will be awarded with the understanding and agreement that it is for the sole convenience of CES, its Members or Participating Entities in New Mexico. CES reserves the right to obtain like goods and services from another source when necessary.

Contractor: As defined in Construction Industries Licensing Act, 60-13-1 NMSA 1978: "contractor" means any person who undertakes, offers to undertake by bid or other means, or purports to have the capacity to undertake, by himself or through others, contracting. Contracting includes constructing, altering, repairing, installing or demolishing any: road, highway, bridge, parking area or related project; building, stadium or other structure; airport, subway or similar facility; park, trail, bridle path, athletic field, golf course or similar facility; dam, reservoir, canal, ditch or similar facility; sewerage or water treatment facility, power generating plant, pump station, natural gas compressing station or similar facility; sewerage, water, gas or other pipeline; transmission line; radio, television or other tower; water, oil or other storage tank; shaft, tunnel or mining appurtenance; leveling or clearing land; excavating earth; air conditioning, conduit, heating or other similar mechanical works; electrical wiring, plumbing or plumbing fixture, consumers' gas piping, gas appliances or water conditioners; or similar work, structures or installations which are covered by applicable codes adopted under the provisions of the Construction Industries Licensing Act.

The Act includes subcontractor and specialty contractor; and includes a construction manager who coordinates and manages the building process; who is a member of the construction team with the owner, architect, engineer and other consultants required for the building project; and who utilizes their skill and knowledge of general contracting to develop schedules, prepare project construction estimates, study labor conditions and advise concerning construction.

Contractor Invoice: The Contractor will send an invoice to CES or a CES Member after the delivery of goods and/or services. Goods and services will be invoiced at current contract pricing approved by AEPA including the 2% administrative fee and if applicable, the local New Mexico Gross Receipts Tax.

Contractor's Quote to CES Member or Participating Entity: When preparing a proposal under a CES awarded contract, the Contractor must clearly identify and break out supplies, materials, equipment, services, labor, and local New Mexico Gross Receipt Tax into individual line items as they appear on the Contractor's awarded price schedule or pricing methodology. Stated prices must include the CES two percent (2%) administrative fee. All costs associated with preparing cost proposals and job orders shall be the responsibility of the Contractor and must be based on a detailed scope of work and in compliance with an approved pricing methodology.

Credit Hold: The Contractor must agree not to place CES, its Member or Participating Entity on "credit hold" without ten (10) days advanced notice in writing to all parties, by letter or e-mail. Before CES can pay a Contractor's invoice, it must collect payment from the CES Member or Participating Entity that received the product. CES believes it is better for the Contractor if CES places the slow-paying agency on "credit hold". If a Contractor places CES on "credit hold," agencies that pay promptly are penalized. If, on the other hand, CES places the offending agency on "credit hold", payment is more likely to result and only the offender is punished.

Disclosure of Confidential Information: Any confidential information provided to the Contractor by CES, its Members or Participating Entities or developed by the Contractor based on information provided by CES, its Members or Participating Entities in the performance of this Agreement shall be kept confidential and shall not be made available to any individual or organization by the Contractor without the prior written approval of CES, its Members or Participating Entities. Upon termination of this Agreement, Contractor shall deliver all confidential material in its possession to CES, its Members or Participating Entities within thirty (30) business days of such termination. Contractor acknowledges that failure to deliver such confidential information to CES, its Members or Participating Entities will result in direct, special and incidental damages.

Indemnification: To the fullest extent permitted by law, Contractor must, defend, indemnify and hold harmless

CES, its Members, its Participating Entities, its officers and employees, against any and all liability, claims, demands, actions, damages, losses, judgments, settlements, personal injury (including sickness, disease, death, and bodily harm), property damage (including loss of use), infringement, government action and all expenses, including attorneys' fees and litigation expenses, demands or expenses asserted by a third-party, caused by, or resulting from, Contractor 's and/or its employees, act(s) or omissions(s) while Contractor, and/or its employees, perform(s) or fails to perform its obligations and duties under this agreement or acts or omissions occurring outside of this agreement Any equipment or facilities damaged by Contractor s' operation shall be repaired and/or restored to their original condition at Contractors' expense. Contractor shall at all times keep in force liability insurance limits as outlined in this solicitation. Failure to maintain current coverage in the amounts stated may result in termination of this agreement. CES shall be named as a co-insured on the insurance policy and the policy shall provide that the policy cannot be modified or cancelled without the approval of CES.

"This provision shall survive any termination of this Agreement. Contractor will promptly advise CES in writing of any action, administrative or legal proceedings or investigation as to which defense and indemnification shall apply."

Indemnification Intellectual Property: The Contractor shall defend, at its own expense, CES, its Members and Participating Entities against any claim that any product or service provided under this Agreement infringes any patent, copyright or trademark, and shall pay all costs, damages and attorney's fees that may be awarded as a result of such claim. In addition, if any third party obtains a judgment against CES, its Members and Participating Entities based upon Contractor's trade secret infringement relating to any product or services provided under this Agreement, the Contractor agrees to reimburse CES, its Members and Participating Entities for all costs, attorneys' fees and the amount of the judgment. To qualify for such defense and/or payment, CES, its Members and Participating Entities shall:

1. Give the Contractor written notice, within forty-eight (48) hours, of its notification of any claim;
2. Allow the Contractor to manage the defense and settlement of the claim as permitted by law; and
3. Cooperate with the Contractor, in a reasonable manner, to facilitate the defense or settlement of the claim.

CES, its Members and Participating Entities Rights: If any product or service becomes, or in the Contractor's opinion is likely to become, the subject of a claim of infringement, the Contractor shall, at its sole expense:

1. Provide CES, its Members and Participating Entities the right to continue using the product or service and fully indemnify CES, its Members and Participating Entities against all claims that may arise out of CES, its Members and Participating Entities use of the product or service;
2. Replace or modify the product or service so that it becomes non-infringing; or
3. Accept the return of the product or service and refund an amount equal to the value of the returned product or service, less the unpaid portion of the purchase price and any other amounts, which are due to the Contractor. The Contractor's obligation will be void as to any product or service modified by CES, its Members and Participating Entities to the extent such modification is the cause of the claim

Insurance: On contract award, the Contractor will, at its own expense, purchase and maintain insurance that will protect it from claims that may arise out of or as a result from its activities under this contract, where those activities are performed by it, by any Subcontractor, by anyone directly or indirectly employed by any of the Contractors or by anyone for whose acts the Contractor may be liable during the entire performance period of this contract. The Contractor must furnish a Certificate of Insurance to the CES procurement officer prior to official award. If policy changes occur during the life of the contract, it is the Contractor's responsibility to provide updated proof of coverage to the CES procurement officer.

1. Will provide to CES proof of coverage under the Workman's Compensation Insurance, as required by the Labor Laws and New Mexico Statutes.
2. Bidders will submit a certificate of general liability insurance for personal injury, occupational disease, sickness or death, and property damage. Insurance will include "occurrence" claim provisions. Minimum acceptable coverage is one million dollars (\$1,000,000) combined single limit for bodily injury and property damage, or seven hundred fifty thousand dollars (\$750,000) bodily injury and two hundred fifty thousand dollars (\$250,000) property damage (each occurrence). **The Contractor will name CES and the CES Member as co-insured up to the limits of the Tort Claims Act.**

3. Will provide to CES a certificate of comprehensive vehicle liability insurance, for both owned and non-owned vehicles, shall be one million dollars (\$1,000,000) per occurrence combined single limit for both personal injury and property damage.
4. If required for professional services, will provide a certificate of errors and omissions insurance for damages caused by an error, omission, or any negligent acts caused by the Contractor and its Subcontractors in the performance under this agreement. Combined singled limit per occurrence is one million dollars (\$1,000,000) and the annual aggregate limit of not less than two million dollars (\$2,000,000). The bidder will provide "tail" coverage at the completion of any contract entered into by CES or its Members for a minimum of 12 months, or the maximum time period reasonably available in the marketplace. The Contractor shall furnish certification of "tail" coverage as described following contract completion. This will be a condition of the final acceptance of work or services.
5. In addition, Contractor must provide, upon request, identical certification of insurance to any CES Member or Participating Entity using this contract. Prior to commencing any work, all Subcontractors must procure and maintain at its own expense until final acceptance of the work, written insurance coverage, and insurer's acceptance to the prime Contractor. All Subcontractors will provide workers' compensation insurance, which waives all subrogation rights against the prime Contractor and CES/CES Member/Participating Entities.

Lease and Rentals: Contractor can allow CES Members to enter into rent, lease or lease/purchase agreements, providing such agreements are in compliance with 6-6-12 NMSA 1978 Exemption from Bateman Act, 13-1-67 NMSA1978 Definition; local public body, and Public Education Department policies, rules and regulations. CES will not collect lease payments. Contractor agrees that leases will be in compliance with the Uniform Commercial Code. All terms of leasing must be included in the proposal with interest rates described as related to a government standard. Contractor must indicate in its response to this solicitation if the shipping costs for the return of leased or rented equipment are the responsibility of the CES Member and what that cost will be. No sale of a contract to a third party will be made without informing CES and the CES Member of the transfer. If Contractor sells a lease contract to a third party, the cost of return must not be greater than the cost of return to the original Contractor.

As required by New Mexico law, the lease agreement with the CES Member or Participating Entity will need to contain a termination provision for Non-Appropriation of Funds. In the event no funds or insufficient funds are appropriated and budgeted by CES, its Members or Participating Entities (Lessee) governing body or are otherwise unavailable in any fiscal year for the payment of lease and other amounts due under any lease, the lease shall terminate on the last day of the fiscal period for which appropriations were received or other amounts are available to pay amounts due under the lease without penalty or expense to the Lessee. It is the decision of CES, its Members, or Participating Entities to determine the sufficiency of funds, which determination shall be accepted by the Lesser and is final. The Lessee shall give the Lesser or its Assignee written notice at least thirty (30) days in advance of such occurrence.

Legal Remedies: All claims and controversies are subject to the New Mexico Procurement Code, NMSA 1978, and Sections 13-1-21 through 13-1-199.

Liens: All materials and services will be free of all liens.

Local Representation: Depending on the type and level of products and services offered, the Contractor must demonstrate their sales, support, and service staff are physically located where they can respond to and deliver services in a timely and cost-effective manner.

Manufacturer Endorsement: The Contractor must demonstrate it is an authorized distributor of the products and services offered, has access to manufacturer's technical support and warranty services, and possesses the certifications required to install, configure, and maintain the products offered within the state of New Mexico.

New Mexico Procurement Code: Sections 13-1-21 through 13-1-199 NMSA 1978 may be cited as the "Procurement Code".

Offer Acceptance Period to Execute a Contract with CES: In order to allow CES the opportunity to evaluate

the bids approved by AEPA, CES requires that the AEPA approved Contractor submit to CES a complete electronic copy of its response to AEPA's solicitation with original signatures within fifteen (15) days of CES's request. CES will issue its supplemental packet within thirty (30) days after receipt and review of the approved Contractor response. The approved Contractor will have fifteen (15) days to return the CES supplemental packet. After CES receives the request information in the supplemental packet, CES issue a contract for the products and services as approved by AEPA.

Ordering Process: Contractor agrees to adhere to CES' ordering process(es).

Ownership of Materials and Documents: CES, its Members or Participating Entities shall be the sole owner of all right, title and interest, including copyright, in and to all software, plans, diagrams, facilities, and tools (hereafter "**materials**") which are originated or created through Contractor's work pursuant to this Contract. Contractor, for valuable consideration herein provided, shall execute all **documents** necessary to assign and transfer to, and vest in CES, its Members or Participating Entities all Contractor's rights, title and interest in and to such original **materials**, including any copyright, patent and trade secret rights which arise pursuant to Contractor's work under this Contract.

Patent and Copyright Infringement: Contractor will, at their expense, defend CES and its Members and Participating Entities against any claim that any equipment or software supplied hereunder (even if such equipment or software are modified by CES or its Members, subject to the last paragraph of this section) infringe a patent or copyright in the United States, or a U.S. Territory, and will pay all costs, damages and attorney's fees that a court finally awards as a result of such a claim. To qualify for such a defense and payment, CES must:

1. Give Contractor prompt written notice of any such claim after becoming aware of such claim.
2. Allow Contractor to control and fully cooperate with Contractor in the defense and all related settlement negotiations.

CES will be reimbursed for all expenses incurred by CES in fully cooperating with Contractor as specifically requested by contract. CES is not required to incur any expenses specified in this paragraph, which are not reimbursable, by the Contractor. If any CES Member and Participating Entities are involved by any party in any way, the same provisions that apply to CES in this paragraph will apply to the CES Member or Participating Entity. Contractor's obligation under this section is conditioned on CES' agreement that if the subject of such a claim, CES will permit the Contractor, at its expense and option, either to procure the right for CES and its Members or Participating Entity to continue using the equipment and/or software, or to replace or so modify with equipment or software which are functionally equivalent so that they become non-infringing. If neither of the foregoing alternatives is available on terms which are reasonable in Contractor's judgment and satisfactory to CES, CES will request its Members or Participating Entity to return the equipment or software on written request by Contractor at Contractor's expense.

Contractor agrees to refund CES, its Members or Participating Entities a refund for returned equipment as depreciated unless otherwise mutually agreeable in writing. The depreciation will be an equal amount per year over six (6) years. In the event that Contractor's written request for return is made after full depreciation, the Contractor will pay CES, or its Members who purchased the equipment, an amount equivalent to the fair market value of the returned equipment. If CES, or any of its Members or Participating Entities, fails to return the equipment, the Contractor is not obligated to that Member under this clause.

Contractor will have no obligation with respect to any such claim based upon a Member's or Participating Entity's modification of the equipment or software or combination, operation or use with apparatus, data or programs not furnished by Contractor. However, one Member's or Participating Entity's action will not preclude Contractor's obligation to others not having modified their equipment or software.

Payment by CES: CES will make every effort to collect payment from Members or Participating Entities for the purchase of goods and services within thirty (30) days after the receipt of goods or services and a correct invoice of amount due, unless a good faith dispute exists as to any obligation to pay all or a portion of the account. Any offer that requires payment in less than forty-five (45) days shall not be considered. CES must first receive payment from the Member or Participating Entity in order to process payment to the Contractor. Any Contractor whose business would be in jeopardy due to slow payments is encouraged not to respond. It has been CES' experience that public agencies always pay, but many are slow in processing payments.

Payments by Member or Participating Entities: For the purchase by a Member or Participating Entity directly from the Contractor for goods and services that have been received and accepted. Payment from the Member or Participating Entity to the Contractor will be made within forty-five (45) days after the receipt of a correct invoice, unless a good faith dispute exists as to any obligation to pay all or a portion of the account. If a dispute arises or an agency's account becomes delinquent, the Contractor is encouraged to contact and request assistance from CES. Any offer that requires payment in less than forty-five (45) days shall not be considered.

Payment of Administrative Fee: When a CES Members or Participating Entities issue payment directly to the Contractor for goods and services received and accepted. The Contractor will, upon receipt of payment from a CES Member or Participating Entity, issue payment to CES for an administrative fee in an amount equal to two percent (2%) of the total invoice amount.

Price List: The AEPA Contractor will submit to CES and/or its Members and Participating Entities (if requested) or make available on its website all applicable pricing for all products and services proposed, approved, and awarded under this solicitation. Price lists submitted must be in accordance and comply with the AEPA's terms, conditions, and the requirements of the CES purchasing process utilized to facilitate eligible procurement agencies' staff to place and process orders. When utilizing any of the pricing methodologies identified and required within this solicitation, such discounts and pricing will include the CES two (2%) percent administrative fee, must be submitted in the format required, and can be audited by CES.

Public Record: All documents associated with this AEPA contract will become the property of CES and be a matter of public record available for review, after the final award notification according to the "New Mexico Inspection of Public Records Act" (NMSA 1978, Chapter 14, Article 2). All proposals may be reviewed under the supervision of CES staff by appointment, from 9:00 a.m. to 4:00 p.m., Monday through Friday, at 4216 Balloon Park Road NE, Albuquerque, New Mexico, 87109.

Safety Measures: Contractor will comply with all federal and state of New Mexico safety regulations.

Severability: The provisions of this contract are severable to the extent that any provision or application held to be invalid will not affect any other provision or application of the contract, which may remain in effect without the invalid provision or application.

Smoking: All Contractors and subcontractors must adhere to CES Member or Participating Entity smoking policies.

Taxes: Prices offered will not include applicable State of New Mexico Gross Receipts Tax (NMGR). All applicable NMGR must be listed as a separate line item on all invoices. No gross receipts taxes can be collected on delivery charges to the agency's location.

1. There is no NM State Gross Receipt Taxes NMGR applied to the price of non-construction supplies, materials, and equipment.
2. There will be NM State Gross Receipt Taxes NMGR applied to any non-construction services and professional services based on the location of the provider.
3. There will be NM State Gross Receipt Taxes NMGR applied to any construction product and/or service based on the physical location of the construction site.
4. Indian Reservation or Tribal Tax: If goods or services are delivered to locations on a Indian reservation or purchased by tribal governments, they are subject to tribal taxes.

5. A Bidder will be required to provide tax indemnification number (CRS) issued by New Mexico Taxation and Revenue Department at time of contract award.

Termination for Convenience: CES can, by written notice stating the effective date, terminate the contract issued for convenience in whole or in part, at any time. CES shall pay Contractor as full compensation for performance until such termination as follows:

1. The unit or pro-rata order price for the delivered and accepted portion; and
2. A reasonable amount, not otherwise recoverable from other sources by Contractor as approved by CES with respect to the undelivered or unaccepted portion of the service, provided compensation shall in no event exceed the total contract price.

Termination for Default: CES reserves the right to terminate in whole or any part of the contract due to the failure of the Contractor to carry out any obligation, term or condition of the contract. CES may issue written notice to the Contractor for acting or failing to act under the following conditions.

1. The Contractor provides material that does not meet the specifications of the contract.
2. The Contractor fails to complete the services set forth in the specifications of the contract.
3. The Contractor fails to complete the work required or to furnish the materials required within the specified time.
4. The Contractor fails to make progress in the performance of the contract and/or gives CES cause to believe that the contractor will not or cannot perform the requirements of the contract.
5. The Contractor fails to observe any or all of the terms and conditions of the contract.
6. The Contractor accepts purchase orders, based on this contract, directly from a CES Member or Participating Entity and then invoices them directly.
7. Any other conditions that, in the opinion of CES, warrants such action.

Upon receipt of a written notice, the Contractor will have ten (10) days to provide a satisfactory response in writing to CES. Failure on the part of the Contractor to satisfactorily respond can result in CES terminating the contract.

Termination for Gratuity: CES shall, by written notice, cancel this contract if it is found that gratuities, in the form of entertainment, gifts or otherwise, were offered or given by the Contractor or any agent or representative of the Contractor, to any employee of CES with a view toward securing a contract or the respect to the performance of the contract. Paying the expenses of normal business meals, which are generally made available to all eligible school and government employees, shall not be prohibited by this paragraph. Samples of software, equipment, or hardware provided to CES for demonstration, evaluation, or loan purposes are not considered gratuities.

Termination for Non-Performance or Contractor Deficiency: CES can terminate any contract if CES Members have not used the contract in any 12-month period, or if purchase orders total less than \$10,000 per year. CES reserves the right to cancel the whole or any part of this contract due to failure by Contractor to carry out any obligation, term or condition of the contract. CES may issue a written notice to Contractor for acting or failing to act in any of the following:

1. Providing material that does not meet the specifications of the contract;
2. Failing to adequately perform the services set forth in the scope of work, specifications or contract;
3. Failing to complete required work or furnish required materials within a reasonable amount of time;
4. Failing to make progress in performance of the contract and/or giving CES reason to believe that contractor will not or cannot perform the requirements of the contract;
5. Performing work or providing services under the contract prior to receiving a purchase order from CES for such work;
6. Accepting purchase orders based on this contract from CES Members and/or invoicing CES Members directly.
7. Fails to observe any or all of the terms and conditions of the contract.
8. Any other conditions that, in the opinion of CES, warrants such action.

Upon receipt of a written notice, contractor will have ten (10) days to provide a satisfactory response to CES. Failure to adequately address all issues of concern may result in contract cancellation. Upon cancellation under

this paragraph, all goods, materials, work, documents, data, and reports prepared by Contractor under the contract will become the property of the CES Member on demand.

Termination for Non-Appropriation: Any individual Member's or Participating Entities' project may be terminated if insufficient appropriations or authorizations do not exist due to changes in state or federal law, or because of court order, or because of insufficient appropriations made available to Members or Participating Entities governing board and/or the New Mexico State Legislature. Such termination will be effected by sending fifteen (15) days written notice to the Contractor. The CES Members or Participating Entities decision as to whether sufficient appropriations and authorizations are available shall be accepted by the Contractor and shall be final.

B. Construction Terms and Conditions – For construction products and services.

Additional Contract: A contract between the CES Member or Participating Entity and the Contractor for construction will be an industry standard agreement. The parties may agree to use the American Institute of Architects (AIA) General Conditions of Contract for Construction Form A201 as a guide.

Bonds:

1. Upon execution of a contract between a CES Member/Participating Entity and the prime Contractor for a project with a value twenty-five thousand (\$25,000) or more, will provide performance and payment bonds from a surety company authorized to do business in New Mexico in accordance with the New Mexico Insurance Code and be a surety listed in the US Treasury Circular 570.
2. The prime Contractor will execute a performance bond in an amount equal to one hundred percent (100%) of the price specified in the contract between the CES Member or Participating Entity and the prime Contractor by a surety company authorized to do business in New Mexico in accordance with the New Mexico Insurance Code and be a surety listed in the US Treasury Circular 570. Performance bonds between the CES Member or Participating Entity and the prime Contractor will be on standard AIA or similar forms.
3. All suits for nonpayment or nonperformance will be filed as allowed under New Mexico law.
4. Any Subcontractor providing or performing one hundred and twenty-five thousand dollars (\$125,000) or more of work for an individual project, must submit to the prime Contractor a performance and payment bond equal to one hundred percent (100%) of the subcontract cost from a surety company authorized to do business in New Mexico in accordance with the New Mexico Insurance Code and be a surety listed in the US Treasury Circular 570.
5. Acceptable forms of bonds are AIA Document A310-2010 Bid Bond or NASBP that includes the same language as the AIA Document A310-2010.

Construction: As defined in the New Mexico Procurement Code Regulations under 13-1-40 NMSA 1978. Definition: "construction" means building, altering, repairing, installing or demolishing in the ordinary course of business any road, highway, bridge, parking area or related project; building, stadium or other structure; airport, subway or similar facility; park, trail, athletic field, golf course or similar facility; dam, reservoir, canal, ditch or similar facility; sewage or water treatment facility, power generating plant, pump station, natural gas compressing station or similar facility; sewage, water, gas or other pipeline; transmission line; radio, television or other tower; water, oil or other storage tank; shaft, tunnel or other mining appurtenance; electrical wiring, plumbing or plumbing fixture, gas piping, gas appliances or water conditioners; air conditioning conduit, heating or other similar mechanical work; or similar work, structures or installations. Construction shall also include: leveling or clearing land; excavating earth; drilling wells of any type, including seismographic shot holes or core drilling; and similar work, structures or installations.

Construction Contractor and Subcontractor Licenses: The prime Contractor and any Subcontractors shall possess the appropriate New Mexico Construction Industries Division (NMCID) Contractor's license required to provide the construction products services. Any Contractor using subcontractors must hold a current and appropriate Contractor's license, as defined in Construction Industries Licensing Act, 60-13-1 NMSA 1978. It is the responsibility of the Contractor to ensure that any subcontractors performing under this contract hold and maintain the appropriate Contractor's licenses as defined in Construction Industries Licensing Act, 60-13-1 NMSA 1978. The Contractor and any Subcontractors must maintain and keep current all licenses during the term of the contract.

New Mexico Building Codes: The Contractor when providing construction services must adhere to the most current version of the New Mexico Building Codes.

New Mexico Construction Industries Division: New Mexico Construction Industries Division (NMCID) is a state agency that is responsible for and enforce all licensing requirements for any one engaged in construction-related contracting in New Mexico. This includes general construction work, electrical, mechanical, and plumbing and LP gas. The activities that are considered to be contracting in New Mexico are defined in the Construction Industries Licensing Act, NMSA 1978, Section 60-13-3.

New Mexico Contractor Public Works Registration Requirement: As defined in Public Works Minimum Wage Act 13-4-13.1 NMSA 1978. In order to respond to a request for proposals or to be considered for award of any portion of a public works project greater than Sixty Thousand Dollars (\$60,000) for a public works project that is subject to the Public Works Minimum Wage Act [13-4-10 to 13-4-17, NMSA 1978], the Contractor, serving as a prime Contractor or not, shall be registered with the New Mexico Department of Workforce Solutions. The State, or any political subdivision of the State, shall not accept a bid on a public works project subject to the Public Works Minimum Wage Act from a prime Contractor that does not provide proof of required registration for itself. Contractors and subcontractors may register with the New Mexico Department of Workforce Solutions on a form provided by the division and in accordance with the Department of Workforce Solutions department rules.

Because this solicitation is for an indefinite quantity and the amount of work to be performed on individual projects is not known, CES is requiring that all Contractors be registered on or before the date of the proposal opening and keep their registration current during the term of the contract and all contract extensions.

New Mexico Public School Facilities Authority: New Mexico Public School Facilities Authority (NMPSFA) is the administrative unit created by the New Mexico legislature to carry out and act on behalf of the Public School Capital Outlay Council to administer, coordinate and provide general oversight for "state-funded construction", which is defined as a building or appurtenance to a building that is built in whole or in part with state capital outlay monies. As part of their oversight function, NMPSFA will receive and review construction project documents and coordinate with other state agencies such as NMCID, Environment Department, Department of Energy, Minerals and Natural Resources, State Fire Marshal's Office, etc., to ensure compliance with all applicable adequacy standards, rules, regulations, building, plumbing, electrical, fire prevention, and mechanical codes adopted by the state, county, city, town or fire district in which the construction project is located.

New Mexico Public Works Act: Sections 13-4-1 through 13-4-43 NMSA 1978 may be cited as part of the "Procurement Code".

New Mexico State Wage Rates: It is the contractor's responsibility to be acquainted with the New Mexico Department of Labor's rules, regulations, procedures and requirements relating to state wage rates, and to comply with state and federal regulations regarding payment of wages on public projects. The contractor will pay state wage rates for every job performed under this contract with a total project cost of more than Sixty Thousand Dollars (\$60,000) on an individual basis. The contractor will pay all mechanics and laborers employed on the site of the project by the contractor, unconditionally and not less often than once a week, and without subsequent unlawful deduction or rebate on any account, the full amounts accrued at time of payment, computed at wage rates not less than those stated in the advertised specifications.

New Mexico State Wage Rate Documentation:

1. The New Mexico Department of Workforce Solutions (NMDWS) requires that certain forms be completed for every project in excess of \$60,000. CES will submit for the wage decision and, upon receipt of the decision, will provide it to the prime Contractor. The Contractor is responsible for completing and submitting the required forms to the NMDWS and must provide CES with a copy of the following required forms: Notification of Award, Statement of Intent to Pay Prevailing Wages, and Affidavit of Wages Paid.
2. The prime Contractor must submit the Statement of Intent to Pay Prevailing Wages and the Notification of Award to NMDWS with a copy being mailed, faxed or e-mailed to CES, prior to the start of the project. The Affidavit of Wages Paid must be submitted to NMDWS with a copy being mailed, faxed or e-mailed to CES at the conclusion of your work on the project. The prime Contractor is responsible for insuring that its subcontractor(s) also submit the Statement of Intent to Pay Prevailing Wages and the Affidavit of Wages Paid to NMDWS, with a copy being mailed, faxed or e-mailed to CES.

3. CES will not make any payments until copies of the Notification of Award, Statement of Intent to Pay Prevailing Wages and for projects \$25,000 or greater until the Payment and Performance Bonds are received by CES. Final payment will not be released until CES receives a copy of the Affidavit of Wages Paid.

New Mexico Workforce Solutions Contractor Registration Requirement: In order to submit a bid or response to a request for proposal valued at more than sixty thousand dollars (\$60,000) or to be considered for an award of any portion of a public works project greater than sixty thousand dollars (\$60,000) and for a public works project that is subject to the Public Works Minimum Wage Act (13-4-10 NMSA 1978), the contractor, serving as a prime contractor or subcontractor, shall be registered with the New Mexico Department of Workforce Solutions, Public Works (13-4-14.1 NMSA 1978) before CES can issue a purchase order. (see above)

Payment Retention, Progress Payments:

1. In order to comply with New Mexico Statutes Annotated 1978, Article 28 Retainage, 57-28-1 to 57-28-11, CES will not retain any funds on progress payments during any construction projects. The prime contractor agrees to only request payment for goods and services delivered, received and accepted by the CES Member or Participating Entity.
2. Final payment of a contract, for which progress payments have been made, will not be made until the project is totally completed (including punch list items and close out document delivered), and the final application for payment is signed by the CES Member or Participating Entity, received and audited by CES.
3. If the CES Member or Participating Entity and the prime contractor agree to retainage or a substitute security, the agreement must be in full compliance with New Mexico Procurement Code and applicable laws. If a substitute security or retainage is agreed upon, written notice must be provided to all parties prior to the issuing of a CES purchase order.
4. If the CES Member, Participating Entity, or their designee issues a written statement to the contractor that the estimate of work is not approved and certified, an amount from the progress payment determined to be reasonably sufficient to cover the deficiency set forth in the written finding maybe withheld. In such cases, the contractor agrees to hold CES harmless for any deficiency of payment. If any payment is delayed beyond forty-five (45) days from the due date, the contractor agrees not to charge CES interest on the late payment

Progress Payments for Construction: All progress payments must be invoiced through CES. It is the responsibility of the CES using agency and/or its designee to review and approve any estimates of work completed. If the CES using agency or their designee issues a written statement to the contractor per 57- 28-5 NMSA 1978 A. "If an owner receives an improperly completed invoice, the owner shall notify the sender of the invoice within seven days of receipt in what way the invoice is improperly completed, and the owner has no further duty to pay on the improperly completed invoice until it is resubmitted as complete..." In such cases, the contractor agrees to hold CES harmless for any deficiency of payment.

Quality Control Issues:

1. During the course of the contract, the Member's/Participating Entity's contact person may secure samples according to Construction Industries Division guidelines or industry standards of materials being used from containers at the job site and submit them to an independent laboratory for comparison to specified material.
 - a. Should test results prove that a material is not functionally equal to or better than specified, the prime Contractor will pay for all testing and any cost incurred to have materials installed to replace those found not to comply with the specifications and remove and dispose of the materials not complying.
 - b. Should test results prove that materials tested were functionally equal to the specified material, the prime Contractor will be notified of the results.
2. Should the Member/Participating Entity and the Contractor encounter a situation and/or condition that they cannot agree on or resolve during the execution of the project and/or during the project close-out process, CES has consultants under contract that either of the parties can engage to review, investigate, evaluate, and issue a written report on their findings and propose recommendations/solutions for addressing the concerns and issues.

Site Cleanup: Contractor will clean up and remove all debris resulting from its work as required by the CES Member or Participating Entity. The contractor shall comply with all laws and regulations governing disposal of construction and hazardous materials. Upon completion of the work, the premises will be left in a neat,

unobstructed condition with everything in good repair and order.

Site Examination: Contractor shall familiarize itself with the site, in order to anticipate unseen problems that may develop as the work progresses. Failure to have visited the site before submitting a job order proposal shall in no way relieve the contractor from furnishing any materials or performing any work required to complete the project in accordance with the contract documents, without additional cost to the CES Member/Participating Entity.

Site Preparation: Prior to a purchase order being issued by a CES Member or Participating Entity, the size, location and site conditions that exist at the time the contractor takes possession and/or control must be clearly identified and stated in writing. The contractor will not begin a project for which the site is not prepared or in the condition agreed upon in writing by the CES Member or Participating Entity, unless contractor decides to accept the site as is and is willing to perform the preparation work necessary at no cost, or until the CES Member or Participating Entity has included the cost of site preparation in a purchase order to CES. Site preparation may include, but is not limited to, moving furniture, clearing the site, securing the site, installing wiring for networks or power and similar pre-installation requirements.

Subcontractors: If it is necessary for the Offeror to contract with third party firms to provide various goods and services, the following will apply:

1. In accordance with the "Subcontractor Fair Practices Act", 13-4-31 to 13-4-42, NMSA 1978, the following information is required to be submitted with any job order project:
 - a. The name of each subcontractor who will be performing work or rendering service on the public works project and whose total contract will be the greater of:
 - i. Five Thousand Dollars (\$5,000); or
 - ii. One half of one percent (.005%) of the total project (to be estimated by the architect and/or engineer of record).
 - b. Address of the place of business
 - c. Subcontractor license number
 - d. Type of work or services to be performed by the subcontractor.
 - e. Pursuant to Section 13-4-38 NMSA 1978, if an Offeror fails to list a subcontractor in excess of the listing threshold on any job order contract, and they do not state that the provider is a sole source or that they will put all work that exceeds the threshold to individual bid each time, they are stipulating that they are fully qualified to perform the proposed products and services themselves and that they will perform all work themselves. After the specific job order contract award, any change in subcontractors must be approved by CES and the CES Eligible Agency, otherwise, the Offeror will be guilty of violation of the Subcontractors Fair Practices Act and subject to the penalties provided therein.
2. Subcontractor must be registered with New Mexico Department of Workforce Solutions, Public Works section.
3. CES and its Eligible Agencies reserves the right to approve, reject and replace any subcontractor proposed by the Offeror pursuant to 13-4-36 NMSA 1978.
4. Subcontractors will need to provide performance and payment bonds to prime Contractor if the sub-contract is greater than \$125,000 pursuant to 13-1-148.1 .
5. Any agreements with subcontractors shall incorporate, by reference, the terms and conditions of this solicitation and each individual project contract.
6. No subcontract will be entered into with any unlicensed party. Contractor must use subcontractors openly, include such arrangements in the proposal and certify upon request that such use complies with the rules of the NMCID, New Mexico Public Works Act and New Mexico Procurement Code.
7. Subcontractor Payment: Contractor agrees to pay subcontractors in a timely manner and in accordance with the New Mexico Prompt Payment Act pursuant to 57-28-5 NMSA 1978. If Contractor receives a progress payment from CES, the Contractor will pay subcontractor(s), "...within seven days after receipt of payment from the owner, contractor or subcontractor..." pursuant to 57-28-5 C. NMSA 1978. CES will contract to provide release of liens from subcontractors within fifteen (15) days of date of payment. Failure to pay subcontractors, pursuant to 57-28-5 C. NMSA 1978, for work faithfully performed and properly invoiced can result in the suspension or cancellation of this contract.

8. Subcontractor's labor used must be of a standing or affiliation that will permit the work to be carried on harmoniously, without delay and will not cause any disturbance, interference or delay to the progress of the project. Subcontractor and lower-tier subcontractors will not employ anyone whose employment might be objected to by prime Contractor or Member.
9. It is the responsibility of the Contractor to inform all suppliers and subcontractors that this contract is a cooperative purchasing contract and that the CES Eligible Agency must make payments to CES before CES can issue progress payments to the Contractor. The Contractor must provide CES with all subcontractors and suppliers information utilized for any individual project performed.
10. Contractor and Subcontractor are responsible for obtaining background checks for any employee working on a CES project per the CES Member's background check policy.

19. North Dakota, North Dakota Educators Service Cooperative (NDESC)

i. General Terms and Conditions that apply for all categories

- a. **Governing Law:** The laws of the State of North Dakota govern all contracts resulting from this IFB. Each and every provision of law and clause required by law to be included in a contract shall be deemed to be inserted herein and the contract shall be read and enforced as though it were included. If through mistake or otherwise any such provision is not included, or is not currently included, then upon application of either party the Contract shall be physically amended to make such inclusion or correction.
- b. **Governing Venue:** The resulting contract award shall be deemed to have been made and performed in Cass County, North Dakota. For the purpose of venue, all legal arbitration or causes for action arising out of the resulting agreement shall be brought to the courts of Cass County, North Dakota.
- c. **Hazardous Substances:** All hazardous products purchased by members shall include a Safety Data Sheet (SDS) with the delivery.
- d. **Lease and Rental Agreements:** The Vendor may allow participating agencies to enter into a rental, lease, or lease purchase agreements, providing such agreements are in compliance with North Dakota Statutes and guidelines. NDESC must receive a report annually, summarizing the executed lease purchases along with a summary of the participating agencies' purchases. NDESC will not collect lease payments or be involved in the terms and conditions of the lease. All lease arrangements are between the Vendor and the participating agency. The Vendor agrees that leases will be in compliance with the Uniform Commercial Code. The applicable administrative fee must be included in the lease cost based on the total value of the goods and applicable services purchased. This fee is referred to under the Technical Specifications. The Vendor should attempt to work with NDESC's current leasing vendor. Note, the current leasing vendor may require a minimum purchase amount to begin the leasing process. Should the Vendor be required to utilize their own financial leasing company, this should be noted/requested as an exception. In the event of a lease, the total administrative fee for the value of goods shall be paid to NDESC by the vendor at the front end of the lease. NDESC reserves the right to review all purchase orders, lease documents and invoices to insure contract compliance.
- e. **Marketing and Promotion:** Upon award and completion of the vendor orientation, NDESC will promote the contract opportunity via its websites. NDESC will also announce the new partnership in its newsletters and will publish the contract and marketing information through hard copy marketing items (i.e. flyers, postcard) and electronic email. Contracts will also be promoted at applicable trade shows, conferences, and meetings on a regular basis. NDESC may assist in the development of these materials if requested by the Vendor, but in all cases shall have the authority to review and approve any marketing materials. If a website is used, the link will be made available from the NDESC website. Any web page or link, or other marketing tools shall be dedicated to NDESC information only.
- f. **Non-Discrimination:** Any resulting contract for on or behalf of participating agencies, said Vendor agrees to:
 - i. That, in the hiring of common or skilled labor for the performance of any work under any contract, or any subcontract, no contractor, material supplier, or vendor, shall, by reason of race, creed, or color, discriminate against the person or persons who are citizens of the United States or resident aliens who are qualified and available to perform the work to which the employment relates;
 - ii. That no contractor, material supplier, or vendor, shall, in any manner, discriminate against, or intimidate, or prevent the employment of any person or persons identified in clause (1) of this section, or on being hired, prevent, or conspire to prevent, the person or persons from the performance of work under any contract on account of race, creed, or color;
 - iii. That a violation of this section is a misdemeanor; and
 - iv. That this contract may be canceled or terminated by the state, county, city, town, school board, or any other person authorized to grant the contracts for employment, and all money due, or to become due under the contract, may be forfeited for a second or any subsequent violation of the terms or conditions of this contract.
- g. **Participating Agency:** A participating agency shall be defined in accordance with Chapter 54-40.3

of the North Dakota Century Code, as amended. An eligible agency includes any school, higher education, city, county, other governmental agency, nonprofit organization, or other entity contracted to conduct business on behalf of a participating agency provided that they are required to follow state and local procurement regulations.

- h. **Substance Use and Conduct:** All Vendor partners and subcontractors must adhere to local substance (alcohol, drug, smoking, etc.) and conduct (dress code, language, parking, etc.) policies while on a participating agencies' premises.
- i. **Vendor Orientation (NDESC 101):** The Vendor and their participating resellers/sub-contractors will be required to participate in an online training session that is designed to educate the Vendor and resellers/sub-contractors on the purpose and nature of NDESC. The Vendor will not be marketed to participating agencies until they have completed the vendor orientation session.

2. Additional Participating Agency Terms and Conditions for Non-Construction Products and Services

If requested by NDESC, the contracted vendor will work with NDESC to develop an order form, or order forms, containing the most commonly purchased items, that NDESC can utilize to market the contracted vendor to its participating agencies.

3. Additional Participating Agency Terms and Conditions for Construction Related Products and Services

Upon acceptance and approval of the Vendor's offer by AEPA, NDESC will independently consider the offer and conduct a conference call with the Vendor to determine if the Vendor is able to meet the necessary requirements for construction related products and services, according to Chapter 48-01.2 of the North Dakota Century Code, and to enter and execute a contract in the state of North Dakota. Once NDESC and the Vendor are able to confirm that business is able to be conducted in North Dakota, NDESC will make a final decision to complete the contract execution process.

For all quotes provided to participating agencies, for construction related projects, products and services, the contracted vendor must also send a duplicate quote to NDESC. The quote provided to NDESC must include the contact information of the participating agency.

Performance Bond (for construction and/or installation related projects): Performance bonds will be required on all projects valued at fifty-thousand dollars (\$50,000) or more in North Dakota. All performance bonds will be issued by a corporate surety authorized to do business in the state in which the work will be conducted and by a surety listed in the US Treasury Circular 570. Performance bonds will be posted by the Vendor and submitted to the specific participating agency for the assigned project. Should the contract be the result of a piggyback agreement, performance bonds will reflect each state's bonding requirements.

The Vendor will execute a performance bond in an amount equal to one hundred percent (100%) of the value specified in the contract between the participating agency and the Vendor, unless the participating agency requires less to be posted. This bond will protect all persons supplying labor and material to the Vendor for the performance of the work provided in the contract. Subcontractors who may work on the contract may have to provide the Vendor with a performance bond. If the contract price increases after the bond is provided, the participating agency may consider obtaining additional bonds from the Vendor.

The Vendor will deliver the performance bond to the eligible participating agency at the time the contract is executed between the agency and the Vendor. Work will not commence between the Vendor and the eligible participating agency until the performance bond is received by the participating agency and a copy has been sent to NDESC via email (info@purchasingconnection.org). The Vendor will be responsible for providing NDESC with a copy of all contracts and bonds in accordance with NDESC purchasing procedures. Should the Vendor fail to satisfactorily perform the contract, the bonding company that provided the performance bond will be required to pay the dollar amount of the bond to the participating agency.

It is the Vendor's responsibility to ensure that they can obtain the required bonding for all construction products based on an awarded contract arising from this solicitation. Payment will not be issued for any project for which the required bonds have not been received.

4. Procedure for Contract Award, Notification and Processing Orders

Once the award is recommended by the AEPA Review Committee, NDESC considers the recommendation based on the value of the potential contract for its participating agencies. Participating agency is defined as any city, county, public or private educational agency, nonprofit or governmental agency that is a participant of NDESC. In the event of an award by the Board of Directors, NDESC will inform its members of the award and contract by the following methods along with contract instructions and ordering process.

- a. The contract is listed and promoted on the NDESC website (www.ndesc.org).
- b. Announcing the award in NDESC newsletters.
- c. NDESC will publish the contract and marketing information through a hard copy marketing flier and electronic email. Contracts are promoted through PDF and a hard copy product catalog distributed at statewide trade shows and agency meetings on a regular basis. NDESC will require a marketing flier, brochure, or other similar marketing pieces, in an editable, electronic format, from each vendor promoting the available contract with the vendor, and/or a web page or link. NDESC may assist in the development of the marketing flier and material (if requested by vendor), but in all cases shall have authority to review and approve any marketing materials. If a web site is used, the link will be made available from the NDESC web page. Any web page or link, or other marketing tool shall be dedicated to AEPA information only.
- d. When the member identifies a desired product or service, the member and the vendor may negotiate with each other to establish a description of items and/or services. The vendor shall quote a price to the member, in writing, using AEPA established discounts and including the two percent (2%) administrative fee in the quoted price. The administrative fee shall be based upon the total cost of goods and/or services including installation costs. The administrative fee shall not be listed as a separate line item on the quote. When a member decides to purchase through the NDESC-AEPA contract, the member issues the purchase order directly to the vendor. The purchase order must include the total invoiced cost, based on
 - i. The total cost of goods, service, and installation, including the 2% administrative fee.
 - ii. Notification will be made to the vendor in the event the purchase order is not in compliance with the contract and adjustments will be made at that time. NDESC and the vendor will mutually resolve any issues with regard to past purchases. The purchase orders are to continue to be processed and viewed as approved unless notified by NDESC otherwise. All sales and transactions may continue without delay or in anticipation of the NDESC purchase order verification.
 - iii. Once all the items and services on the purchase order have been delivered to the member in a complete and satisfactory manner, the vendor then files a copy of the final invoice, which is available to NDESC by request in support of the quarterly sales summary. The invoice is to be marked "Copy".
 - iv. Vendor makes all deliveries and installations of products and services. NDESC does not warehouse items or provide installation services.
 - v. This administrative fee is to be paid by the vendor to NDESC, quarterly, within 20 working days after the end of each fiscal quarter. The AEPA vendor shall also submit to NDESC a sales report, in Excel format, listing the following information:
 1. Name of purchasing agency
 2. Address of purchasing agency
 3. Date of purchase
 4. Invoice number
 5. Amount of purchase
 6. Administrative fee generated by sale
 7. Savings generated by sale
 8. This report shall include all sales made and payments received by the vendor in said quarter. The sales report shall be emailed to Jane Eastes at jeastes@lcsc.org and copied to Lori Mittelstadt at lmittelstadt@lcsc.org. The administrative fee payment shall be delivered to Jane Eastes, NDESC, 1001 East Mt. Faith, Fergus Falls, MN 56537. The check shall be made out to North Dakota Educators Service Cooperative.
 - vi. NDESC requires that all participating vendors offer the contract opportunity to all NDESC participating agencies.

5. **Express Online Marketplace:** NDESC provides participating agencies with an online purchasing platform called Express, powered by EqualLevel. Through Express, agencies are able to search for and purchase items. Essentially, Express is a one-stop shop for many of NDESC's commodity based contracts. A Vendor does not have to have an e-commerce site to be included in Express. NDESC expects growth in the number of agencies utilizing the marketplace and the volume of sales to grow significantly. NDESC will work with the Vendor to determine if the contract agreement is suitable for the online platform. If deemed suitable, NDESC will require integration into Express within a timely manner.

20.OHIO COUNCIL OF EDUCATIONAL PURCHASING CONSORTIA (OCEPC) 2019

A. General Terms and Conditions that apply for all Categories:

1. Compliance with Laws/Forum Designation

Contractor shall comply with Federal, State, and Local Laws, Codes and Regulations while fulfilling the contract. It is the Contractor's responsibility to be aware of and comply with all state and local laws governing this procurement. Applicable laws, codes, and regulations (etc.) must be followed even if not specifically identified herein. Contractor shall verify to the Ohio Council of Educational Purchasing Consortia (OCEPC), its Member Agencies and other qualifying purchasers that the Contractor is complying with all Federal, State and Local Laws, Codes and Regulations while fulfilling the contract. Moreover, this contract shall be governed by and construed in accordance with the laws of the State of Ohio without giving effect to its principles of conflict of law. Legal proceedings arising under this contract shall be brought in an Ohio Court of Common Pleas of the County where the Member Agency's main office is located.

2. Delinquent Tax Affidavit

Contractor shall provide an affidavit relating to delinquent taxes as may be required by Ohio Revised Code Section 5719.042.

3. Secretary of State Registration

Contractor shall meet and maintain all registration requirements as necessary to conduct business in the State of Ohio, including but not limited to registration with the Ohio Secretary of State.

4. Findings for Recovery

Contractor warrants and represents that it is not subject to a finding for recovery under Ohio Revised Code Section 9.24, or that Contractor has taken the appropriate remedial steps required under Ohio Revised Code Section 9.24, or otherwise qualifies under Ohio Revised Code Section 9.24.

5. Ohio Workers Compensation Insurance

Contractor, and any subcontractors hired by Contractor shall, at their own expense, maintain in force for the duration of the project workers' compensation and employer's liability insurance as required by the laws of the State of Ohio.

6. Project Personnel, Student Safety and Background Checks

Member Agency shall have the right to reject the participation of any personnel of Contractor in the performance of the services if, in relation to the work assigned to them, the Member Agency deems such personnel to lack the skill, experience and expertise required to perform the services or if Member Agency considers their performance to be substandard or otherwise detrimental to the proper completion of the services. Contractor will advise Member Agency promptly of any change in the project manager or other key personnel assigned to the performance of the services.

Contractor acknowledges that the safety of the Member Agency's students, employees, officials and guests is of the utmost importance. Contractor will endeavor to ensure that its officers, employees, agents, representatives, and consultants will take no action that would jeopardize the safety of the Member Agency's students, employees, officials, or guests. The Member Agency reserves the right to require Contractor's officers, employees, agents, representatives and consultants to wear identification and stay in designated work areas at all times while on the Member Agency's property. The Member Agency shall have the right to effect the immediate removal of any person associated in any way with Contractor from Member Agency property for failure to wear identification, for being outside a designated work area, for fraternizing with or engaging in any improper behavior directed toward or in the vicinity of students, employees, officials, or guests of the Member Agency or for any other good cause.

Contractor shall perform or cause to be performed an Ohio Bureau of Criminal Investigation and Identification and Federal Bureau of Investigation criminal background check of any personnel that will be performing the services within the proximity of minors. Contractor shall notify the Member Agency of any proposed employee who has been convicted, pled guilty or pled "no contest" to a criminal offense, and the Member Agency reserves the right to reject the proposed employee with a criminal background. No person shall be employed by Contractor who has been found guilty of any of the criminal offenses enumerated in Ohio Revised Code Section 3319.39 without prior approval of the Member Agency.

7. Independent Contractor

Contractor shall be an independent contractor and neither Contractor nor any of its subcontractors, nor the employees of any thereof, shall be deemed to be the servants, employees, or agents of Member Agency. Contractor shall be responsible for paying all costs related to its employees and managers performing the services. Contractor shall remain liable and responsible to Member Agency for all of its obligations under this contract, regardless of whether the services are performed by the Contractor or a subcontractor of any tier.

8. Ownership of Instruments of Service

Drawings, data and other documents prepared by, or with the cooperation of, the Contractor pursuant to this contract shall become, upon payment of all undisputed compensation due the Contractor from the Member Agency, the property of the Member Agency. Such drawings, data or other documents may be used by the Member Agency or others employed by the Member Agency without compensation to the Contractor.

9. Audit

Member Agency may audit and inspect Contractor's records and accounts at any time during the Contractor's performance of the services and for a period of two (2) years following the completion or termination of the services for the purpose of verifying any invoice and underlying documentation presented by Contractor, it being understood that Contractor agrees to preserve all such documents through such two- (2) year period.

10. Notices

Unless otherwise expressly provided in this contract, all notices and other communications given under the contract shall be in writing and shall be deemed effective upon receipt by the addressee at its address as set forth in the contract or at such other address as such party shall have notified the other in writing.

11. Non-Appropriation

If the Member Agency fails to appropriate sufficient monies in any fiscal year for payments due under the contract and other funds are not available for such payments, then a "Non-Appropriation" shall be deemed to have occurred. If a Non-Appropriation occurs, then Member Agency will give Contractor prompt notice of such Non-Appropriation. This contract shall thereupon terminate without penalty or expense to the Member Agency.

12. No Personal Liability

It is understood and agreed that under no circumstances will the Member Agency's board members, officers, employees, or agents be personally liable for any obligations or claims arising out of or related to the contract.

13. Miscellaneous

Headings and titles of articles, paragraphs and other subparts of this contract are for convenience of reference only and shall not be considered in interpreting the text of this contract.

This contract and any appendices constitute the entire agreement of the parties with respect to the subject matter hereof and supersedes all prior agreements or understandings with respect thereto.

No contract amendments can be made without the approval of the AEPA membership.

B. Non-Construction Products and Services:

1. Bus Purchases

For the purchase of school buses, the successful Contractor shall provide bonds required by Ohio Revised Code Sections 153.54 and 153.571.

C. Construction Products and Services:

For construction improvements, the following shall apply:

1. The successful Contractor shall provide such bonds required by Ohio Revised Code Sections 153.54 and 153.571.
2. Progress payments and retainage shall be in accordance with the provisions of the Ohio Revised Code including Ohio Revised Code Sections 153.12 and 153.14.
3. In the event that the agreement is subject to the prevailing wage requirements of either Ohio Revised Code Chapter 4115 or the Davis-Bacon Act, then the contract between the Member Agency and the Contractor shall contain the applicable rates and such terms and provisions as may be required by law.
4. Contractor shall comply with all applicable licensing requirements, including those of the Ohio Construction Industry Licensing Board.

D. Procedures for Processing Orders:

The OCEPC will keep informed its Member Agencies and other qualified purchasers of contract information via web site and through other marketing strategies. A list of OCEPC Member Agencies along with addresses, phones, contacts, etc. will be made available to successful Contractors. After contracts are awarded, Contractors may contact the OCEPC Member Agencies and other qualifying purchasers concerning their products and services.

Participating Member Agencies and other qualified purchasers will submit all purchase orders directly to the Contractor.

The Contractor price shall include a two percent (2%) administrative fee that the Contractor will collect from the Member Agency or other qualified purchaser. Administrative fees are to be remitted to the OCEPC on April 15, July 15, October 15 and January 15 of every calendar year with checks payable to the Southwestern Ohio Educational Purchasing Council, 303 Corporate Center Dr. Suite 208, Vandalia, OH 45377.

The Contractor will compile a quarterly report showing all purchases made by the OCEPC Member Agencies and other qualified purchasers under this contract at the conclusion of each calendar quarter. These reports shall be attached to the administrative fee remittance.

E. Agencies Allowed to Purchase under Member Agency:

All member cooperatives of the OCEPC and their individual Member Agencies are eligible to participate and purchase from the awarded AEPA contracts. All Ohio K-12 school districts, including Boards of Developmental Disabilities, Educational Service Centers, and Instructional Technology Centers, are eligible to participate and purchase from the awarded AEPA contracts. In addition, all colleges and universities, state, cities, counties, townships and other governmental agencies are eligible to participate if the AEPA contracts satisfy their individual procurement requirements.

Revised: December 2, 2009

Approved: December 14, 2009

Reviewed: May 12, 2010

Revised: May 27, 2011

Reviewed and Approved: September 14, 2011

Reviewed and Approved: May 14, 2014

Revised and Approval: May 20, 2015

Reviewed and Approved: May 18, 2016

Revised and Approved May 17, 2017

21. Oregon, Intermountain Educational Service District (IMESD)

A. Additional Agency Terms and Conditions – all categories

Intermountain Education Service District (“IMESD”) is an educational service district organized under the laws of the STATE OF OREGON. Pursuant to Oregon Law ORS 279A and IMESD is authorized to cooperate with other entities and in such regard is authorized to cooperate with them in the purchasing of goods and services pursuant to these contract documents. As other entities cooperate with IMESD to take advantage of the goods and services made available pursuant to these contract documents, the terms and conditions of any such sales shall be in accordance with the contract documents.

Additionally Senate Bill 3184 enables Oregon's Education Service Districts to offer the services they provide to component school districts to other organizations. For the past 10 years, the InterMountain ESD (formerly Umatilla-Morrow ESD) has been a leader in expanding revenue available for schools and IMESD programs by providing these services outside of 19 local school districts. (Reference: ORS 334.185)

Under Oregon public contracting rules, each individual public agency will have its own local rules it must adhere to, in addition to statewide public contracting laws. InterMountain Education Service District does not presume that its cooperative purchasing program will necessarily comply with every agency's internal public contracting rules. We always advise potential customers to review the bid solicitation carefully and recommend review by their legal department and/or procurement personnel to assure that contracting laws are complied with.

ADVERTISING AND MARKETING: Bidders must demonstrate they possess the necessary resources and have a proven track record to market, offer, obtain, deliver, install and provide the sales and technical support services to IMESD and its participating agencies within the state of Oregon in a timely and cost effective manner.

APPLICABLE LAW AND VENUE: Any dispute arising out of any of the contract documents, or out of their performance, shall be decided by litigation in the Circuit Court of the State of Oregon in the county of Owner's residence, the parties consenting to jurisdiction in said court and permanently waiving jurisdiction in any other court, state or federal. In the event of litigation the prevailing party shall be entitled to an award of reasonable attorney's fees and costs at trial and upon any appeal thereof.

In the event that the successful bidder breaches a term of condition of a contract awarded, the IMESD may terminate the contract. In addition to the right to terminate due to the successful bidder's breach, and all other rights and remedies contained in other provisions, the IMESD reserves all its rights and remedies at law and in equity available due to the breach.

HAZARDOUS CHEMICALS: The Successful bidder shall supply current MSDS for all products as required below even if these sheets have been supplied in previous years.

The agencies participating on IMESD agreement will need MSDS and labels for certain products defined as hazardous chemicals by the State of Oregon in accordance with ORS 654.025(2) and 656.726(3). The successful bidder has the responsibility to determine such products and to provide MSDS and labels for such products. The MSDS shall be received by the IMESD by or at the time of the initial shipment of such products.

These requirements have been determined by the State of Oregon Workers Compensation Department, and published as Oregon Administrative Rules 437, Division 2 Hazard Communication. This document is available from Hazard Communication Coordinator, Accident Prevention Division, State of Oregon, Labor and Industries Building, 350 Winter St. NE, Salem, OR 97310, phone: (503) 378-3272 or (800) 922-2689 any local Accident Prevention Division Office.

HOLD HARMLESS: Bidders shall indemnify, hold harmless, and defend the IMESD from any and all liabilities, settlements, losses, penalties, costs, expenses, attorney fees (including attorney fees on appeal) in collection with any action, suit or claim based upon or allegedly based upon, resulting from or allegedly resulting from the successful bidder's negligence, omission, activities or services provided pursuant to a contract awarded to such bidder.

LAW OF THE STATE OF OREGON: Any contract between the IMESD and a bidder shall be entered into within the State of Oregon, and the laws of said state, whether substantive or procedural, shall apply to the contract.

In addition to any requirements listed, vendor shall comply with all, current, applicable state, federal and local laws, regulations and ordinances. If through mistake or otherwise any such provision is omitted then submission by either IMESD or the vendor-partner the contract shall be amended to make such inclusion or correction. IMESD Also reserves the right to amend the contract resulting from state law changes. Vendor-partners will be sent written notification of such changes.

SEVERABILITY: The parties agree that if any term or provision of a resultant contract is declared by a court of competent jurisdiction to be illegal or in conflict with any law the validity of the remaining terms and provisions shall not be affected,

and the rights and obligations of the parties shall be construed and enforced as if the Contract did not contain the particular term or provision held to be invalid.

TAXES: Taxes, whether State or Federal, shall not be included in bid prices. Our Employer Identification No: 93-6000924 indicated our tax exemption status as a political subdivision. Contractor must certify compliance with the Oregon tax laws in accordance with ORS 305.385 when applicable.

B. Additional Agency Terms and Conditions – Non-construction Products and Services

None

C. Additional Agency Terms and Conditions – Construction Products and Services

1. Prevailing wage rates/Davis-Bacon.

As set forth in the conditions below, if this is a public works project (as defined below) Oregon State prevailing wage rates will apply unless exempted. If federal funds are being used, Bidders must take into account the need to comply with the Davis-Bacon Act. If both the federal and state prevailing wages are required the Contractor is required by law to pay the greater of the applicable prevailing wage. Pursuant to ORS 279C.365 no bid will be considered unless the bid contains a statement by the Bidder as a part of its bid that the provision of ORS279C.840 will be complied with.

(a) If contract is \$50,000.00 or under and there are no federal funds involved the contract is exempted from prevailing wages pursuant to ORS 279C.810(2) (a).

(b) If contract exceeds \$50,000.00 and there are no federal funds involved, existing prevailing wage rate of the State of Oregon will apply. No worker may be paid by any Contractor or Subcontractor a wage less than the wage required by ORS 279C.840. Every subcontract shall include the requirements of this section. Prevailing wages, state and federal, can be seen at the websites referred to in Section 6(a), Additional Requirements of Oregon Law for Public Contracts, Public Works, and Improvements and Miscellaneous Provisions.

(c) If contract exceeds \$50,000.00 and/or federal funds are involved, unless otherwise exempted by law, Contractor shall comply with ORS 279C.800 to 279C.870 relating to the payment of prevailing wages; Contractor shall also comply with the federal Davis-Bacon Act to the extent applicable. No worker may be paid by any Contractor or Subcontractor a wage less than the wage required by ORS 279C840 and if the state and federal prevailing wage laws both apply, Contractor shall pay as wages the great of the applicable prevailing wage. Every Subcontractor shall include the requirements of this section. Additional Requirements of Oregon Law for Public Contracts,

2. Residence status of Bidder

Each Bidder must identify in its bid whether the Bidder is a resident Bidder, as defined in ORS 279A.120.

3. Licensure

If the contract involves asbestos or asbestos abatement, the contactor or subcontractor must be licensed under ORS 468A.720.

4. Bonding

If this contract is a public improvement contract in excess of \$100,000.00, at the time of the execution of the contract, the successful Bidder shall also deliver to the Owner good and sufficient bonds endorsed on forms supplied by Owner, in sums equal to the contract price, for the faithful performance of the contract, and for the payment of all claims for labor, materials, equipment, and rental equipment that may result from work performed pursuant to the contract documents. The successful Bidder shall not be allowed to execute the contract without the concurrent delivery to the Owner of the bonds required by this paragraph on the required forms. At owner's sole discretion, Contractor shall be subject to disqualification and forfeiture of bid security for breach of this section. If Bidder is disqualified, Owner may award the contract to another Bidder.

5. Subcontractor Disclosure

Unless exempted by ORS 279C.370(1)(c) for public improvement contracts, all Bidders shall within two hours of the date and time of the deadline when bids are due submit information about certain first-tier Subcontractor when the contract value for public improvements is greater than \$100,000 (see ORS 279C.370). Specifically, when the contract amount of a first-tier Subcontractor furnishing labor or labor and materials would be greater than or equal to:

- (i) 5% of the project bid, or \$15,000, or
- (ii) \$350,000 regardless of the percentage, Bidders must disclose the following information about that Subcontractor:

- (a) the Subcontractor's name, and
- (b) the category of the work that the Subcontractor would be performing, and
- (c) the dollar amount of the subcontract

If Contractor will not be using any Subcontractors that are subject to the above disclosure requirements, Contractor is required to indicate "NONE" on the reply form.

THE OWNER MUST REJECT A BID IF THE BIDDER FAILS TO SUBMIT THE DISCLOSURE FORM WITH THIS INFORMATION BY THE STATED DEADLINE.

FIRST TIER SUBCONTRACTOR DISCLOSURE FORM

Project name:
 Bid #:
 Bid Opening Date:
 Name of Bidding Contractor:
 Required Disclosure Deadline:

Bids which are submitted by Bid Closing, but for which a required disclosure submittal has not been made by the specified Disclosure Deadline, are not responsive and shall not be considered for Contract award.

See the certification above the signature line on the second page of this form regarding the Subcontractors that must be disclosed.

The Owner will insert "NA" above if the contract value is not anticipated to exceed \$100,000. Otherwise this form must be submitted either with the bid or within two (2) working hours after the advertised bid closing date and time; but no later than the DISCLOSURE DEADLINE stated above.

This form may not be submitted by facsimile. It is the responsibility of Bidders to submit this disclosure form and any additional sheets, completely filled out and signed, by the specified disclosure deadline.

List below the name of each Subcontractor that will be furnishing labor or will be furnishing labor and materials and that is required to be disclosed, the category of work that the Subcontractor will be performing and the dollar value of the subcontract. Enter "None" if there are no Subcontractors that need to be disclosed. (Attach additional sheets if needed.)

NAME OF CATEGORY OF DOLLAR VALUE
 SUBCONTRACTOR WORK

_____	_____	_____
_____	_____	_____
_____	_____	_____
_____	_____	_____

Failure to submit this form by the disclosure deadline will result in a nonresponsive bid. A nonresponsive bid will not be considered for award.

CERTIFICATION

It is certified that the above listed first-tier Subcontractor(s) are providing labor, or labor and material, with a dollar value equal to or greater than:

- (a) 5% of the total Contract Price, but at least \$15,000 [if the dollar value is less than \$15,000 do not list the Subcontractor above], or
- (b) \$350,000 regardless of the percentage of the total Contract Price.

Form submitted by (insert Bidder name):
 Contact name:
 Telephone number:

**Additional Requirements of Oregon Law for Public Contracts, Public Works, and Improvements;
 Miscellaneous Provisions**

“Owner” means the public entity executing the Contract of which these provisions are a part.

“Public improvement” means projects for construction, reconstruction or major renovation on real property by or for a public agency.

“Public Works” shall mean roads, highways, buildings, structures and improvement of all types, the construction, reconstruction, major renovation or painting of which is carried on or contracted for by any public agency to serve the public interest by does not include the reconstruction or renovation of privately owned property which is leased by a public agency.

(1) In reference to ORS 279B.220 and 279C.505. Contractor shall:

(a) Make payment promptly, as due, to all persons supplying to Contractor labor or material for the performance of the work provided for in the contract.

(b) Pay all contributions or amounts due the Industrial Accident Fund from the Contractor or Subcontractor incurred in the performance of the contract.

(c) Not permit any lien or claim to be filed or prosecuted against the Owner on account of any labor or material furnished.

(d) If the contract is for a public improvement, demonstrate to Owner that Contractor has an employee drug testing program in place.

(e) Pay to the Department of Revenue all sums withheld from employees pursuant to ORS 316.167.

(2) In reference to ORS 279C.515 regarding contracts for public improvements:

(a) If the Contractor fails, neglects or refuses to make prompt payment of any claim for labor or services furnished to Contractor or a Subcontractor by any person in connection with the contract as such claim becomes due, the Owner may pay such claim to the person furnishing the labor or services and charge the amount of the payment against funds due or to become due the Contractor by reason of such contract.

(b) If the contract is for a public improvement and if the Contractor or a first-tier Subcontractor fails, neglects or refuses to make payment to a person furnishing labor or materials in connection with the contract within thirty days after receipt of payment from the Owner or a Contractor, the Contractor or first-tier Subcontractor shall owe the person the amount due plus interest charges commencing at the end of the ten day period that payment is due under ORS 279C.580(4) and ending upon final payment, unless payment is subject to a good faith dispute as defined in ORS 279C.580. The rate of interest charged to the Contractor or first-tier Subcontractor on the amount due shall equal three times the discount rate on ninety-day commercial paper in effect at the Federal Reserve Bank in the Federal Reserve district that includes Oregon on the date that is thirty days after the date when payment was received from the Owner or from the Contractor, but the rate of interest shall not exceed 30 percent. The amount of interest may not be waived.

(c) If the contract is for a public improvement, or is related to a contract for a public improvement, and if the Contractor or a Subcontractor fails, neglects or refuses to make payment to a person furnishing labor or materials in connection with the contract, that person may file a complaint with the Construction Contractor’s Board, unless payment is subject to a good faith dispute as defined in ORS 279C.580.

(d) The payment of a claim in the manner authorized in this section of this contract shall not relieve the Contractor or the Contractor’s surety from any obligation with respect to any unpaid claims.

(3) Relating to ORS 279B.020 and ORS 279C.520. Contractor shall comply with ORS 279B.020 and ORS 279C.520 in their entirety (when applicable), and in this regard:

(a) No person shall be employed for more than ten hours in any one day, or forty hours in any one week except in cases of necessity, emergency, or where the Owner absolutely requires it, and in such cases, the employee shall be paid at least time and half pay:

(i) For all overtime in excess of eight hours a day or forty hours in any one week when the work week is five consecutive days, Monday through Friday; or

(ii) For all overtime in excess of ten hours a day or forty hours in any one week when the work week is four consecutive days, Monday through Friday; and

(iii) For all work performed on Saturday, Sunday, and on any legal holiday specified in ORS 279B.020 and 279C.540.

(iv) Contractor shall comply with the notice and posting requirements of ORS 279B.020 and 279C.520(2). Contractor shall pay employees for overtime work performed under this Contract in accordance with ORS 653.010 to 653.261 and the Fair Labor Standards Act of 1938 (29 USC 201, et seq.).

(4) If the contract is for a public improvement, Contractor shall at its sole expense comply with any and all applicable statutes or ordinances, and all regulations of any agencies, whether federal, state, local or tribal, dealing with the prevention of environmental pollution and the preservation of natural resources including without limitation water that affect the performance of this contract.

The following agencies, as well as others, may have pertinent regulations:

Federal: Army Corps of Engineers, Federal Energy Regulatory Commission, Environmental Protection Agency, Dept. of Human and Health Services, Dept. of Interior including but not limited to the US Fish and Wildlife Service, Department of Labor, and Water Resources Council.

State: Columbia River Gorge Commission, Department of Energy, Department of Environmental Quality, Department of Fish and Wildlife, Department of Human Resources, Soil and Water Conservation Commission, and Oregon Water Resources Department.

Local: City and County wherein the project is to be undertaken.

Tribal: Confederated Tribes of the Umatilla Indian Reservation.

(5) In relation to ORS 279B.230 and 279C.530, Contractor shall comply in their entirety, and in this regard:

(a) Contractor shall promptly, as due, make payment to any person, co-partnership, association or corporation, furnishing medical, surgical and hospital care or other needed care and attention, incident to sickness or injury, to the employees of Contractor, of all sums which the Contractor agrees to pay for such services and all monies and sums which the Contractor collected or deducted from the wages of employees pursuant to any law, contract or agreement for the purpose of providing or paying for such service.

(b) All employers, including Contractor, that employ subject workers who work under this contract in the State of Oregon shall comply with ORS 656.017 and provide the required workers compensation coverage, unless such employers are exempt under ORS 656.126. Contractor shall ensure that each of its Subcontractors complies with these requirements.

(6)

(a) If the contract is for public works and is over \$50,000, Contractor, unless otherwise exempted by law, shall comply with ORS 279C.800 to 279C.870 relating to the payment of prevailing wages; Contractor shall also comply with the federal Davis-Bacon Act to the extent applicable. The prevailing rates of wage, state and federal, made available on the internet are hereby incorporated by reference; they may be seen at various sites including at www.boli.state.or.us/BOLI/WHD/PWR and www.access.gpo.gov/davisbacon/or.html. If the state and federal prevailing wage laws both apply, Contractor shall pay as wages the greater of the applicable prevailing wage. Contractor shall comply with all wage reporting and certification requirements of the prevailing wage laws and/or the Davis-Bacon Act, as applicable.

(b) Before starting Work the Contractor shall file with the Construction Contractors Board, and maintain in full force and effect, the separate public works bond required by Oregon Laws 2005, Chapter 360, and OAR 839-025-0015, unless otherwise exempt under those provisions. The Contractor shall also include in every subcontract a provision requiring the Subcontractor to have a public works bond filed with the Construction Contractors Board before starting Work, unless otherwise exempt, and shall verify that the Subcontractor has filed a public works bond

(7) The following apply to contracts for public improvements:

(a) Contractor shall comply with ORS 279C.580, dealing with Contractor's relations with Subcontractors. Without limiting the generality of the foregoing, in this regard Contractor shall include a clause in each subcontract for property or services entered into by the Contractor and a first-tier Subcontractor, including a material supplier, for the purposes of performing the contract:

(i) that obligates the Contractor to pay the first-tier Subcontractor for satisfactory performance under its subcontract within ten days out of such amounts as are paid to the Contractor by the Owner; and

(ii) that obligates the Contractor, if payment is not made within thirty days after receipt of payment from the Owner, to pay to the first-tier Subcontractor an interest penalty on amounts due in the case of each payment not made in accordance with the payment clause required by the preceding paragraph. The interest penalty shall be for the period beginning on the day after the required payment date and ending on the date on which payment of the amount due is made, and shall be computed at the rate specified in ORS 279C.515(2).

(b) Contractor shall include in each of its subcontracts, for the purpose of performance of work in relation to project, a provision requiring the first-tier Subcontractor to include a before clause and an interest penalty clause conforming to the foregoing standards in each of its contracts and to require each of its Subcontractors to include such clauses in their subcontracts with each lower-tier Subcontractor or supplier.

(c) Nothing stated herein shall be construed to preclude the negotiations allowed pursuant to ORS 279C.580(5).

(8) If any work supplied pursuant to the contract requires licensing with the Construction Contractors Board or the State Landscape Contractors Board, Contractor must be so licensed in order to submit a bid for the contract, and Contractor and all relevant Subcontractors must remain licensed during the period required for performance. Contractor certifies that all Subcontractors and workers will be properly licensed to perform the work required by this Contract before their commencement of work.

(9) If this contract is for public improvements, then retainage in the amount of 5% of the amount due shall be withheld in accordance with Oregon laws, including ORS 279C.550 et seq.

(10) If this contract is for a public improvement, and unless exempted by resolution of the Owner, Contractor shall comply with ORS 279C.380 and execute and deliver to Owner a good and sufficient performance bond and payment bond to be approved by Owner in a sum equal to the contract price.

By way of supplement to, and equally binding as, all of the foregoing:

(10.1) Contractor shall comply with all federal, state and local laws, codes, regulations and ordinances applicable to the Work and the Contract. Failure to comply with such requirements shall constitute a breach of Contract and shall be grounds for Contract termination. Without limiting the generality of the foregoing, Contractor expressly agrees to comply with the following as applicable: (i) Title VI and VII of Civil Rights Act of 1964, as amended; (ii) Section 503 and 504 of the Rehabilitation Act of 1973, as amended; (iii) the Health Insurance Portability and Accountability Act of 1996; (iv) the Americans with Disabilities Act of 1990, as amended; (v) ORS Chapter 659A; as amended (vi) all regulations and administrative rules established pursuant to the foregoing laws; and (vii) all other applicable requirements of federal and state civil rights and rehabilitation statutes, rules and regulations. Owner's performance under the Contract is conditioned upon Contractor's compliance with the provisions of ORS 279C.505, 279C.510, 279C.515, 279C.520, and 279C.530, which are incorporated by reference herein.

(10.2) Contractor shall comply with all applicable requirements of federal and state civil rights and rehabilitation statutes, rules and regulations; and

(a) Contractor shall not discriminate against Disadvantaged, Minority, Women or Emerging Small Business enterprises, as those terms are defined in ORS 200.005, in the awarding of subcontracts (ORS 279A.110).

(b) Contractor shall maintain, in current and valid form, all licenses and certificates required by law, regulation, or this Contract when performing the Work.

(10.3) Unless contrary to federal law, Contractor shall certify that it shall not accept a bid from Subcontractors to perform Work as described in ORS 701.005 under this Contract unless such Subcontractors are registered with the Construction Contractors Board in accordance with ORS 701.035 to 701.055 at the time they submit their bids to the Contractor.

(10.4) Unless contrary to federal law, Contractor shall certify that each landscape Contractor, as defined in ORS 671.520(2), performing Work under this Contract holds a valid landscape Contractor's license issued pursuant to ORS 671.560.

(10.5) The following notice is applicable to Contractors who perform excavation Work. ATTENTION: Oregon law requires you to follow rules adopted by the Oregon Utility Notification Center. Those rules are set forth in OAR952-001-0010 through OAR 952-001-0090. You may obtain copies of the rules by calling the center at (503)232-1987.

(11) Contractor must certify compliance with the Oregon tax laws in accordance with ORS 305.385 when applicable.

(12) Upon receipt by Contractor of any notice or claim, pursuant to ORS 279C.600 et seq (concerning action against bonds) Contractor shall immediately notify Owner in writing.

(13) Unless agreed to by Owner in writing, Contractor may not assign, transfer, dispose of, or delegate its duties under the contract.

(14) Contractor shall be responsible for compliance with all local, state, tribal, and federal laws, applicable to any aspect of the work to be performed. It shall be Contractor's responsibility to determine the applicability and requirements of any such laws and to abide by them. Contractor shall indemnify, defend, and hold harmless Owner for any default or breach of Contractor in this regard.

(15) The submission of a bid for this contract is certification by Contractor that Contractor has not discriminated and will not discriminate in violation of ORS 279A.110 against any minority, women, or emerging small business enterprises in obtaining any required subcontracts.

(16) If this contract is a public improvement contract for demolition, Contractor shall salvage or recycle constructions and demolition debris if feasible and cost-effective.

(17) If this contract is a public improvement contract for lawn and landscape maintenance, Contractor shall compost or mulch yard waste material at an approved site, if feasible and cost-effective.

(18) Any dispute arising out of any of the contract documents, or out of their performance, shall be decided by litigation in the Circuit Court of the State of Oregon in the county of Owner's residence, the parties consenting to jurisdiction in said court and permanently waiving jurisdiction in any other court, state or federal. In the event of litigation the prevailing party shall be entitled to an award of reasonable attorney's fees and costs at trial and upon any appeal thereof.

D. Procedure for Agencies Processing Orders under IMESD in Oregon

Once the award is made to the vendor, IMESD will market these contracts by: 1) including the contract on the IMESD website, 2) announcing the award in flyers, and 3) attending vendor events throughout school year. A list of schools, contact names, addresses and phone number can be accessed through the Oregon Department of Education website. At this point the vendor contacts schools and schools may contact the vendor. When the school/agency identifies a product or services and agrees on price it issues to Vendor a purchase order for that item or service, referencing the AEPA Bid number. The purchase order must include an additional one percent (2%) administrative fee in the total to be forwarded by the vendor to IMESD after the sale. All participating vendors agree to and are subject to audit proceedings of IMESD member sales.

Upon receipt of the purchase order, the vendor provides the goods or service listed on the purchase order. It is important to remember the vendor makes delivery to the member unless other arrangements are made in cooperation with IMESD. When all items and services on the purchase order have been delivered to the member in a complete and satisfactory manner, vendor then invoices the member for the goods and service. This invoice includes the additional one percent (2%) administrative fee to the total amount invoiced of the goods or service provided by the vendor. This percent is based on the total sales of goods or services. The member then pays the vendor including the one percent (2%) administrative fee. IMESD then invoices the Vendor for the 2% administrative fee based on the sale of goods and services collected by the vendor.

E. Agencies Allowed to Purchase under IMESD in Oregon

The InterMountain Education Service District (IMESD) participates in a national non-profit organization, the Association of Educational Purchasing Agencies (AEPA), which is a procurement vehicle. The mission of IMESD's involvement with AEPA is to cooperatively serve Oregon state agencies members through a continuous effort to explore and solve present and future purchasing needs. AEPA goals include working to secure multi-state volume purchasing contracts with benefits that are measureable, cost-effective and continuously exceed our state member's expectations. InterMountain Education Service District is the member agency representing Oregon in AEPA through an IMESD board approved Memorandum of Understanding between all participating states that are all political subdivisions related to K-12 education. All AEPA bids have been advertised by IMESD in Oregon.

Pursuant to Oregon Law, ORS 279A, InterMountain Education Service District is authorized to offer these contracts to other government entities including school districts, state universities, community colleges, special districts, local and state government.

There is no fee or annual dues to become an IMESD agency member to purchase. InterMountain Education Service District's contract management efforts are funded by a nominal administrative fee paid by the vendor based on sales volume.

22. Pennsylvania, Central Susquehanna Intermediate Unit dba Keystone Purchasing Network

A. Additional Member Agency General Terms and Conditions that apply to all categories

The Keystone Purchasing Network (KPN) is a cooperative purchasing program operated by the Central Susquehanna Intermediate Unit under various state inter-governmental cooperation laws and includes members in several east coast states that currently includes Pennsylvania, Maryland, District of Columbia, New Jersey, New York and Delaware. All applicable Local, State and Federal laws and regulations will apply to any purchases of equipment, services or construction in any of these states and to other states that may be added under the KPN membership throughout the term of these contracts.

Marketing and Advertising under this Agreement: Vendor will actively promote the resulting contract in Pennsylvania, Maryland, District of Columbia, Delaware and New York States. Vendor will comply with the AEPA Marketing program along with the requirement listed below.

1. Vendor will include the approved KPN logo, web address, contract number and toll free number in all print electronic mail and other advertising and promotion intended for release to PA, MD, DC, DE and NY excluding national marketing releases.
2. The KPN logo and associated KPN information shall be of a clearly readable size and in appropriate proportion to other elements in the printed material.
3. Vendor agrees to provide KPN with a copy or proof sheet of the advertisement or promotion material. Vendor will provide KPN with date of release and name of publication, journal, etc.
4. Vendor shall place a supplied KPN vendor sign on booths, tables, etc. of any or all exhibits for which the vendor displays/participates at tradeshow, conventions and the like. Vendor will supply in advance scheduled exhibit dates. Vendor agrees to make available at the exhibit KPN supplied brochures or other promotion materials.
- e. Vendor agrees to insert the approved KPN logo, web address, contract number and toll free number on the vendor's web site promoting or a specific KPN landing page and providing a link to the KPN website.
- f. Vendor will supply product catalog information, product description, pricing, etc., in a spreadsheet format as specified by KPN for inclusion on the KPN website.
- g. Vendor agrees to cooperate in developing appropriate website content to promote its products, services and their advantages to KPN members.
- h. Requested materials will be submitted to KPN within 30 days.

Pricing and Ordering: Vendor will provide all pricing information in an electronic format and/or setup an electronic ordering system that would show the current contract prices along with the KPN administrative fee of 2% or as adjusted by the KPN. In the case of electronic ordering, the KPN would have administrative reporting capabilities with an online ordering system. The KPN administrative fee will apply to all purchases, installation, total lease, total rental prices and all construction and installation and annual maintenance fees and will be included in the net price offered to the purchasing agency.

B. Additional Member Agency General Terms and Conditions for Non-Construction Products and Services

None

C. Additional Member Agency General Terms and Conditions for Construction Products and Services

The following items refer to all projects involving construction or construction related services:

Vendor and/or Contractor agrees that, in performance of the services required under this Agreement, Vendor and/or Contractor shall abide by all Federal, State, Local, and Pennsylvania Department of Education laws, and regulations that may apply to renovation under this bid, including, but not limited to, those listed below. Vendor and/or Contractor shall also abide by the state and local laws and regulations of other states where a member is located. It is the responsibility of the Vendor or Contractor to determine applicability and requirements of any such laws and to abide by them. Additionally, Contractor has the sole responsibility for compliance with all other matters in conjunction with the services to be performed hereunder and in the Invitation for Bid.

PERFORMANCE AND LABOR AND MATERIAL PAYMENT BONDS: the Contractor shall provide a performance bond and a labor and material payment bond, each in the amount of 100% of the contract price, before the award of the contract. (Sections 756 and 757 of the Public School Code of 1949, as amended, and the Public Works Contractors Bond Law of 1967.)

DISCRIMINATION PROHIBITED: According to 62 Pa.C.S.A. 3701, the Contractor agrees that:

- (1.) In the hiring of employees for the performance of work under the contract or any subcontract, no Contractor, Subcontractor or any person acting on behalf of the Contractor or Subcontractor shall by reason of gender, race, creed or color discriminate against any citizen of this Commonwealth who is qualified and available to perform the work to which the employment relates.
- (2.) No Contractor or Subcontractor or any person on their behalf shall in any manner discriminate against or intimidate any employee hired for the performance of work under the contract on account of gender, race, creed or color.
- (3.) The contract may be canceled or terminated by the government agency and all money due or to become due under the contract may be forfeited for a violation of the terms or conditions of that portion of the contract.

HUMAN RELATIONS ACT: The provisions of the Pennsylvania Human Relations Act, Act 222 of October 27, 1955 (P. L. 744) (43 P.S. Section 951, ET. Seq.) of the Commonwealth of Pennsylvania prohibit discrimination because of race, color, religious creed, ancestry, age, sex, national origin, handicap or disability, by employers, employment agencies, labor organizations, Contractors and others. The Contractor shall agree to comply with the provisions of this Act as amended that are made part of this specification. Your attention is directed to the language of the Commonwealth's non-discrimination clause in 16 Pa. Code 49.101.

COMPETENT WORKMEN: Projects where the total estimated cost is \$25,000 or less, Section 7-752 of the Public School Code of 1949, no person shall be employed to do work under such contract except competent and first class workmen and mechanics. No workmen shall be regarded as competent first class, within the meaning of this Act, except those who are duly skilled in their respective branches of labor, and who shall be paid not less than such rates of wages and for such hours work as shall be established and current rates of wages paid for such hours by employers of organized labor in doing of similar work in the district where work is being done.

PENNSYLVANIA PREVAILING WAGE RATES: Projects where the total estimated cost is greater than \$25,000, paid for in whole or in part out of funds of a public body, except for maintenance work or work performed under a rehabilitation program or manpower training program must specify "Prevailing Wages." Further information on implementation of the act, definition of maintenance work and prevailing wage rates may be requested from the Pennsylvania Department of Labor and Industry (800-932-0665 or 717-787-4763). When applicable, use Davis-Bacon wage rates for federally assisted projects. This regulation and the general Pennsylvania prevailing minimum wage rates, (Act 442 of 1961, P.L. 987, amended), as determined by the Secretary of Labor and Industry, which shall be paid for each craft or classification of all workers needed to perform the contract during the anticipated term therefore in the locality in which public work is performed, are made part of this specification.

(1.) The general prevailing minimum wage rates including contributions for employee benefits as shall have been determined by the Secretary of Labor and Industry (hereinafter "Secretary"), which must be paid to the workmen, employed in the performance of the Contract.

(2.) The Contractor shall pay no less than the wage rates as determined in the decision of the Secretary and shall comply with the conditions of the Pennsylvania Prevailing Wage Act approved August 15, 1961 (Act No. 442), as amended August 9, 1963 (Act No. 342), and the Regulations issued pursuant thereto, to assure the full and proper payment of said rates.

(3.) These Contract provisions shall apply to all work performed on the Contract by the Contractor and to all work performed on the contract by all Subcontractors.

(4.) The Contractor shall insert in each of his subcontracts all of the stipulations contained in these required provisions.

(5.) No workmen may be employed on the Work except in accordance with the classifications set forth in the decision of the Secretary. In the event that additional or different classifications are necessary the procedure set forth in the Regulations shall be followed.

(6.) All workmen employed or working on the Work shall be paid unconditionally, regardless of whether any contractual relationship exists or the contractual relationship which may be alleged to exist between any Contractor, Subcontractor and workmen, not less than once a week without deductions or rebate, on any account, either directly or indirectly, except authorized deductions, the full amount due at the time of payment, computed at the rates applicable to the time worked in the appropriate classification. Nothing in this Contract, the Act or the Regulations shall prohibit the payment of more than the general prevailing minimum wage rates as determined by the Secretary to the workmen on the Work.

(7.) The Contractor and each Subcontractor shall post for the entire period of construction the wage determination decisions of the Secretary, including the effective date of any changes thereof, in a prominent and easily accessible place or places at the site of the work and at such place or places used by them to pay workmen their wages. The posted notice of wage rates must contain the following information:

a. Name of project.

b. Name of public body of which it is constructed.

c. The crafts and classifications of workmen listed in the Secretary's general prevailing minimum wage rate determination for the particular project.

d. The general prevailing minimum wage rates determined for each craft and classification and the effective date of any changes.

e. A statement advising workmen that if they have been paid less than the general prevailing minimum wage rate for their job classification or that the Contractor and/or Subcontractor are not complying with the Act or the Regulations in any manner whatsoever, they may file a protest with the Secretary within three (3) months of the date of the occurrence, objecting to the payment to the Contractor to the extent of the amount or amounts due or to become due to them as wages for work performed on the Project. Any workmen paid less than the rate specified in the Contract shall have a civil right of action for the difference between the wage paid and wages stipulated in the Contract, which right of action must be exercised within six (6) months from the occurrence of the event creating such right.

(8.) The Contractor and all Subcontractors, shall keep an accurate record showing the name, craft and/or classification, number of hours worked per day, and the actual hourly rate of wage paid (including employee benefits) to each workman employed by him in connection with the Work and such record must include any deductions from each workman. The record shall be preserved for two (2) years from the date of payment and shall open at all reasonable hours to the inspection of the Owner and

to the Secretary or his duly authorized representative.

(9.) Apprentices shall be limited to such numbers as shall be in accordance with a bona fide apprenticeship program registered with and approved by the Pennsylvania Apprenticeship and Training Council and only apprentices whose training and employment are in full compliance with the provisions of the Apprenticeship and Training Act approved July 14, 1961 (Act No. 304) and the Rules and Regulation issued pursuant thereto shall be employed on the Work. Any workmen using the tools of a craft that does not qualify as an apprentice within the provisions of this submission shall be paid the rate predetermined for journeyman in that particular craft and/or classification.

(10.) Wages shall be paid without any deductions except authorized deductions. Employers not party to a contract requiring contributions for employee benefits which the Secretary has determined to be included in the general prevailing minimum wage rate shall pay the monetary equivalent thereof directly to the workman.

(11.) Payment of compensation to workmen for work performed on public work on a lump sum basis, or a piece work system, or a price certain for the completion of a certain amount of work, or the production of a certain result shall be deemed a violation of the Act and the Regulations, regardless of the average hourly earnings resulting there from.

(12.) Each Contractor and each Subcontractor shall file a statement each week and a final statement at the conclusion of the Work on the Contract with Owner, under oath, and in form satisfactory to the Secretary, certifying that all workmen have been paid wages in strict conformity with the provisions of the Contract as prescribed by the Regulations, or if any wages remain unpaid, to the amount of wages due and owing to each workman respectively.

(13.) The provision of the Act and the Regulations are incorporated by reference in the Contract.

(14.) The current prevailing wage threshold for Pennsylvania is \$25,000. However the threshold may be increased during the term on the contract by legislated action. Vendor will then be required to adjust labor rate for job under the new threshold.

(15.) The following applies to all prevailing wage projects:

E-Verify. The successful Bidder and its subcontractors (as such term is defined in the act) are required to comply with the Public Works Employment Verification Act, Act No. 127, July 5, 2012 (formerly Senate Bill 637). All Bidders shall submit with their Bid a Public Works Employment Verification Form (the "Verification Form") to CSIU - KPN in the form published by the Commonwealth of Pennsylvania, Department of General Services. Per the act, the Verification Form is to be obtained from the Secretary of the Pennsylvania Department of General Services. The Verification Form is presently available on the Department of General Services website. Per the act, the Verification Form shall include a certification that the information in the statement is true and correct and that the individual signing the statement understands that the submission of false or misleading information in connection with the verification shall subject the individual and the public works contractor or subcontractor, as the case may be, to sanctions provided by law; and the verification form shall be signed by a representative of the public works contractor or subcontractor, as applicable, who has sufficient knowledge and authority to make the representations and certifications contained in the statement. Prior to award of a contract or purchase order by a Member Agency to the successful Bidder for a particular project, the successful Bidder shall submit to the Member Agency a Verification Form. Per the act, the successful Bidder's subcontractors shall provide to the Member Agency, and successful Bidder shall cause its subcontractors to provide to the Member Agency, their Verification Forms prior to commencing work on the Member Agency's project.

STANDARD OF QUALITY: The various materials and products specified in the specifications by name or description are given to establish a standard of quality and of cost for bid purposes. It is not the intent to limit the Bidder, the bid or the evaluation of the bid to any one material or product specified but rather to describe the minimum standard. When proprietary names are used, they shall be followed by the words "or alternatives of the quality necessary to meet the specifications". A bid containing an alternative, which does not meet the specifications, may be declared non-responsive. A bid containing an alternative may be accepted but if an award is made to that Bidder the Bidder will be required to replace any alternatives, which do not meet the specifications.

PROVISIONS FOR THE USE OF STEEL AND STEEL PRODUCTS MADE IN THE U.S.: In accordance with Act 3 of the 1978 General Assembly of the Commonwealth of Pennsylvania, if any steel or steel products are to be used or supplied in the performance of the contract, only those produced in the United States as defined therein shall be used or supplied in the performance of the contract or any subcontracts thereunder in accordance with Act 161 of 1982, cast iron products shall also be included and produced in the United States. Act 141 of 1984 further defines "steel products" to include machinery and equipment. The act also provides clarifications and penalties.

PROHIBITION ON CASH ALLOWANCES: Cash allowances are prohibited.

TIME(S) OF COMPLETION OF THE PROJECT: Contractor/Vendor shall complete all work within 180 days after entry into a contract with the individual Member. Member and Contractor/Vendor may agree in writing on a lesser number of workdays depending on the scope of the project.

Owner's Compliance in Retaining Payments: Unless a member stipulates otherwise, Payment Retentions and Progress Payments shall be as follows: Ten percent (10%) of all contract payments shall be retained by the member as insurance of proper performance of the prime Contractor. Prime Contractor agrees to identify the amount of the invoices sent to the member school districts, then send copies of the invoices to the KPN. When fifty percent (50%) of the work is completed, as determined by the school district, one-half (1/2) of the amount retained shall be paid to the prime Contractor, if the prime Contractor requests payment, provided that the prime Contractor is making satisfactory progress and there is no specific cause for greater withholding. After the work is fifty percent (50%) completed, no more than five percent (5%) of the amount of any subsequent progress payments shall be retained, unless the governing board of the member determines that satisfactory

progress is not being made, at which point ten percent retention shall be reinstated. If the member and the prime Contractor agree to a substitute security, the agreement must be in full compliance with Pennsylvania law. If the substitute security is agreed to, the prime Contractor must provide KPN and the member with assigned and acknowledged waiver of any right or power of the obligor to set off any claim against KPN, the member, or the prime Contractor, in relationship to the security assigned. The prime Contractor, as authorized above, will pay any interest due a Subcontractor or material supplier. A Subcontractor to the prime Contractor may request, in writing, that the Subcontractor be notified by KPN within five (5) days of payment of each progress payment made to the prime Contractor. It is the responsibility of the prime Contractor to inform all suppliers and Subcontractors that this contract is a cooperative purchasing contract. Once all bonds are in place, the prime Contractor and the authorized agent of the member will agree in writing upon a schedule of payments based on identifiable milestones. Retaining of payments must be done in accord with 62 Pa.C.S.A. § 3921.

A contract containing a provision for retainage as provided in section 3921 (relating to retainage) shall contain a provision requiring the architect or engineer to make final inspection within 30 days of receipt of the request of the Contractor for final inspection and application for final payment. If the work is substantially completed, the architect or engineer shall issue a certificate of completion and a final certificate for payment, and the government agency shall make payment in full within 45 days except as provided in section 3921, less only one and one-half times the amount required to complete any then-remaining uncompleted minor items, which amount shall be certified by the architect or engineer and, upon receipt by the government agency of any guarantee bonds which may be required, in accordance with the contract, to insure proper workmanship for a designated period of time. The certificate given by the architect or engineer shall list in detail each uncompleted item and a reasonable cost of completion. Final payment of any amount withheld for the completion of the minor items shall be paid upon completion of the items in the certificate of the engineer or architect.

WORKERS' COMPENSATION ACT: The Contractor shall accept, insofar as the work covered by their contract is concerned, the provisions of the Workers' Compensation Act 44 of 1993, and any supplements of amendments thereof, including any which may hereafter be passed, and shall insure the Contractor's full liability there under for all parts of their contract being performed by the Contractor, the Contractor's partners, associates, employees or those of any the Contractor may employ herein, or file with the Entity a certificate of exemption from insurance from the Bureau of Workers' Compensation of the Department of Labor and Industry.

The Contractor shall, at all times, indemnify and save harmless the school entities of and from all claims for Workers' Compensation which may be made by any of the employees of the Contractor or by any of the employees to whom the Contractor may have let the performance of any part of the work embraced by their contract and the Contractor shall appear for and defend the school entities against any and all such claims. The Contractor shall be covered by Employers' Liability Insurance with a minimum limit of \$250,000 for each employee, \$2,000,000 policy limit and \$250,000 for each accident.

ACT 34 CRIMINAL BACKGROUND CHECKS: Independent Contractors and their employees who provide services to a Pennsylvania school entity are required to obtain a report of "Criminal History Record Information" from the Pennsylvania State Police. In the case of non-Pennsylvania residents, a report of "Federal Criminal Record Information" from the FBI is required in addition to the Pennsylvania State Police Report.

Contractors shall be required to do the following:

(1.) Present the original document/s Report of Criminal History Records information from the Pennsylvania State Police, report of Federal Criminal History Record Information from the Federal Bureau of Investigation to the Superintendent or the Superintendent's designee prior to the beginning of work for the school entity. The school entity shall retain a copy of the background check information and shall note on that copy the date on which the original document was inspected and the name of the administrator who viewed the original. This copy shall be retained in the school entity records with the original being returned to the Contractor.

(2.) If any new employees are added to the workforce during the course of the work, such employee(s) must follow the same procedure described above prior to any work for the school entity.

(3.) All costs for the Criminal History Information check(s) shall be borne by the perspective Contractor.

(4.) The school entity shall notify the Contractor in writing if the decision not to employ the Contractor or the Contractor's employees is based in whole or in part on criminal history records information.

(5.) The school entity shall follow the regulations promulgated by the State Board of Education concerning the confidentiality of the Criminal History Report Information obtained pursuant to the Act.

Upon written notice from the school entity, Contractors shall have all such persons removed from the project. School entity's right to declare such persons unfit shall not be limited to the required exclusion of persons from school property as set forth in Section 1-111 of the Pennsylvania School Code and/or Act 151 of 1994.

CHILD PROTECTIVE SERVICES BACKGROUND CHECKS: Prior to commencing work under the contract, the Contractor shall submit for any employee or independent Contractor who would be working on a school entity's site pursuant to work contemplated in the contract, an official clearance statement obtain from the Pennsylvania Department of Welfare pursuant to Act 151 of December 16, 1994 (P.L. 1292) subchapter C2 of the Child Protective Services Act. Contractor shall not allow any prospective employee or independent Contractor on the job site prior to providing the school entity with the above-referred clearance statement for prospective employees or independent Contractors.

ANTIBID-RIGGING ACT (NON-COLLUSION): In accordance with the Commonwealth of Pennsylvania's Antbid-Rigging Act, 62 Pa. C.S.A. § 4501 et seq., the Contractor shall execute and submit with the bid a Non-Collusion Affidavit required by the Agency. Each party to the joint venture must be identified in the bid documents, and an Affidavit must be submitted separately on behalf

of each party.

PREVENTION OF ENVIRONMENTAL POLLUTION: Section 3301 of the Pennsylvania Commonwealth Procurement Code requires that all invitations for Bids and requests for proposals for construction projects issued by any governmental agencies shall set forth any provision of Federal and State statutes, rules, and regulations dealing with prevention of environmental pollution and the preservation of public natural resources that affect the Project. A Notice of said provisions prepared by the Pennsylvania Department of Environmental Resources under Act 247 of 1972, 52 P.S. § 1612 (repealed) is available from Jeffrey L. Kimball, Cooperative Purchasing Services Director at the Keystone Purchasing Network, 90 Lawton Lane, Milton, PA 17847. His telephone number is 570-523-1155 x2130, and his e-mail address is jkimball@csiu.org. Said Notice is hereby incorporated by reference. Contractor is hereby notified and agrees to comply with the terms of all statutes, rules and regulations enumerated in the Notice.

ARCHITECTURAL SERVICES: For those Members who are Pennsylvania Public School Districts, and whose projects require architectural or engineering services, your attention is directed to Section 7-751.1 of the Pennsylvania Public School Code (24 P.S. § 7-751.1), which requires a public school district to engage an architect/engineer that is independent from the Vendor/Contractor's architect/engineer.

MULTIPLE PRIME CONTRACTORS: For those Members who are Pennsylvania Public School Districts, your attention is directed to Section 7-751 of the Pennsylvania Public School Code (24 P.S. § 7-751), which requires a public school district to use separate prime Contractors for plumbing, heating and ventilating, and electrical work. To the extent a school district's project extends beyond general construction services, the school district will need to separately bid plumbing, heating and ventilating, and electrical work, and should consult with its individual solicitor for compliance with Section 7-751. For other Members who are subject to multiple prime requirements under applicable bidding laws, such Members should consult with their individual solicitors for compliance with said requirements.

D. Procedure for Processing Orders

Once the award is made to the Contractor/vendor, KPN will inform its members of the contract by: (1) including the contract in the agency database that is available on the KPN website, (2) announcing the award in its periodic newsletter, and (3) publishing the contract information in a catalog disseminated to all members. A list of members, institution names, contact names, addresses and phone number will be made available to the vendor in an electronic format. At this point the Contractor/vendor contacts the members and members may contact the Contractor/vendor. When the member identifies a product or service it issues a purchase order for that item to the vendor. The vendor's price to its members will include the following administrative fees: currently 2% (two percent) on all supplies, equipment and construction, rental or lease, annual subscription fee, etc.; and others administrative fees as approved by KPN and will be collected from the member or other qualifying purchaser. KPN reserves the right to adjust the administrative fee at any time during the duration of the contract and any renewal period or to modify the administrative fee based on volume of purchase. If the administrative fee is reduced do to the size of the project the vendor will show the adjustment on the quote. The vendor will also compile a quarterly report showing all purchases made by KPN members under this contract. The vendor will also produce an annual report for all purchases made under this contract for a period of beginning with the award of the contract through December 31st and all consecutive 12-month periods if contract is extended. The vendor will make all administrative fee payments to KPN by the 15th of the succeeding month of each 3-month period (quarterly) after they have received payment from the member agency and all checks are to be made payable to the Central Susquehanna Intermediate Unit (CSIU) and sent to Keystone Purchasing Network, 90 Lawton Lane, Milton, PA 17847, and Attention: Jeff Kimball. All reporting of purchases will be broken down by entity by state and will show purchaser, total dollar and date of purchase.

E. Agencies Allowed to Purchase under the Member Agency

The Keystone Purchasing Network (KPN) is a cooperative purchasing program operated by the Central Susquehanna Intermediate Unit under various state inter-governmental cooperation laws. Every public school district in the state is eligible to become a member and must complete a membership application with the KPN. No member is obligated to use these services, but they find the benefits of low price and not needing to go through the bidding process most advantageous. Only those members listed on an approved KPN membership list are eligible to purchase under these contracts. This list may change during the contract period and currently includes members from Pennsylvania, Maryland, New York, Delaware, District of Columbia and other Northeast & Mid-Atlantic states. Vendors may choose to offer KPN in other non-AEPA member states where cooperative purchasing laws allow.

Additional members may include other public educational institutions in the state, college, university, community colleges, vocational schools, charter schools, municipal and county governments and other non-profit organizations from Pennsylvania or any other state where a member is located. Membership from other entities is permitted by various intergovernmental cooperative purchasing laws or regulation from their home state.

As member agencies from other states are added to the membership of the KPN the awarded vendor(s) agrees to abide by all state and local laws and/or regulations that may apply to any purchase of products, services or construction by these agencies. KPN reserves the right to market any AEPA contract under any cooperative program name that it may choose in the future on a national basis in any non-AEPA member state.

23. **TexBuy, a Cooperative Purchasing Shared Services Cooperative Sponsored by the Region 16 Education Service Center Education Service Center**

A. **Additional Agency Terms and Conditions**

- (1) **TexBuy funding:** The total cost of the TexBuy program is funded through a participation fee up to two percent (2%) paid to TexBuy by the Contractors. This fee shall be included in all pricing to TexBuy and its participating agencies. The fee is based on actual Contractor sales. TexBuy does not charge any fees to participating government agencies.
- (2) **Tax exempt status:** All government agencies participating in TexBuy are exempt from payment of taxes under Texas Tax Code §151.309 for the purchase of tangible personal property.
- (3) **Minority and Women Business Enterprise (MWBE) participation:** It is the policy of some TexBuy participants to involve MWBE Contractors in the purchase of goods and services. Contractors shall indicate on the proposal form whether or not they are an MWBE.
- (4) **Bid awards** shall not consider whether a vendor is a member of or has another relationship with any organization and bid specifications (and subsequent contracts) shall not deny or diminish the right of a person to work because of the person's membership or other relationship status with respect to any organization in accordance with Texas Education Code §44.043.
- (5) **Felony Conviction Notice** (TexBuy Contractors will be required to sign a standard affidavit required by the State of Texas): Texas Education Code, Section 44.034, Notification of Criminal History, Subsection (a), states "a person or business entity that enters into a contract with a school district must give advance notice to the district if the person or an owner or operator of the business entity has been convicted of a felony. The notice must include a general description of the conduct resulting in the conviction of a felony." Subsection (b) states "a school district may terminate a contract with a person or business entity if the district determines that the person or business entity failed to give notice as required by Subsection (a) or misrepresented the conduct resulting in the conviction. The district must compensate the person or business entity for services performed before the termination of the contract." This notice is not required of a publicly held corporation.
- (6) **SB 9: Criminal History and Background Checks**, in accordance with Texas Education Code Chapter 22, shall be required should any employee or agent of a contractor awarded a bid have "continuing duties related to the contracted services" with a school district and that employee or agent will have "direct contact with students" (as those terms are defined in 19 Texas Administrative Code §153.1101).
- (7) **Debarment and Suspension:** Under Executive Order 12549 in the Federal Register and Rules and Regulations, TexBuy and TexBuy participants shall not do business with a vendor that has been debarred, suspended, or is otherwise ineligible for participation in Federal Assistance Programs.
- (8) **Conflict of Interest:** In accordance with Texas Local Government Code Chapter 176, vendors/contractors who have a business relationship as defined by Section 176.001(1-a) with a local government entity and meet the requirements under section 176.006(a) must file a Conflict of Interest Questionnaire (Form CIQ) with the local government entity when:
 - (a.) The vendor/contractor has entered into a contract with the local government entity or the local government entity is considering entering into a contract with the vendor.
 - (b.) AND the vendor provides certain income or gifts to a Local Government Officer (LGO) or first-degree relatives as defined in the Texas Government Code
 - (c.) OR a family relationship exists between the LGO and the vendor's employees or agents as defined in the Texas Government Code.
- (9) **EDGAR Certification (Education Department General Administrative Regulations):** In accordance with Federal Regulations under 2 CFR § 200.318(c)(1) – When a Cooperative member seeks to procure goods and services using funds under a federal grant or contract, specific federal laws, regulations, and requirements may apply in addition to those under state law. This includes, but is not limited to, the procurement standards of the

Uniform Administrative Requirements, Cost Principles and Audit Requirements for Federal Awards, 2 CFR 200 (also known as the "Uniform Guidance" or new "EDGAR"). All Vendors submitting Proposals must complete this EDGAR Certification Form regarding the Offeror's willingness and ability to comply with certain requirements which may be applicable to specific TexBuy member purchases using federal grant funds. This completed form will be made available to TexBuy members for their use while considering their purchasing options when using federal grant funds. Members may also require Vendors to enter into ancillary agreements, in addition to the TexBuy's general terms and conditions, to address the member's specific contractual needs, including contract requirements for a procurement using federal grants or contracts.

- (10) **Antitrust Certification:** In accordance with Texas Government Code 2155.005, a local government entity shall not enter into contract with a vendor/contractor that has violated any provision of the Texas Antitrust laws referenced in Texas Business & Commerce Code Chapter 15 or any Federal antitrust laws.
- (11) **H.B 89 Verification:** In accordance with chapter 2270 of the Texas Government code, a local government entity (city, school district, special district, etc) may not enter into a contract with a for-profit company unless the local government entity obtains written verification that the company does not and will not boycott Israel during the term of the contract.

B. Additional Agency Terms and Conditions for Non-Construction Products and Services

- (1) **State of Texas Franchise Tax:** By signature hereon, the bidder certifies that he/she is not currently delinquent in the payment of any franchise taxes owed the State of Texas under Chapter 171, Texas Tax Code.
- (2) **Agricultural products,** including textiles and other similar products, are not to be made available to Texas school districts through the agreement, unless such products produced, processed, or grown in the state of Texas are given a preference in accordance with Texas Education Code §44.042.

C. Additional Agency Terms and Conditions for Construction Products and Services as required by law in the State of Texas:

- (1) **Certification of Residency (TexBuy Contractors will be required to sign a standard affidavit required by the State of Texas):** The State of Texas has a law concerning non-resident Contractors. This law can be found in Texas Government Code under Chapter 2252, Subchapter A. This law makes it necessary for TexBuy to determine the residency of its Contractors. In part, this law reads as follows:

(a.) **Section: 2252.001**

"Non-resident bidder" refers to a person who is not a resident. "Resident bidder" refers to a person whose principal place of business is in this state, including a Contractor whose ultimate parent company or majority owner has its principal place of business in this state."

(b.) **Section: 2252.002**

"A governmental entity may not award a governmental contract to a non-resident bidder unless the nonresident underbids the lowest bid submitted by a responsible resident bidder by an amount that is not less than the amount by which a resident bidder would be required to underbid the nonresident bidder to obtain a comparable contract in the state in which the nonresident's principal place of business is located."

(2) **Security**

- (a.) **Bid Security,** when required by Texas Law, shall be furnished with the bid. The Bid Security shall consist of a certified check, cashier's check or a bid bond in the amount of ten percent (10%) of the total bid (or as otherwise stated in the RFB) that shall be a guarantee to furnish Performance and Payment Bonds. Bid Security shall be to TexBuy.
- (b.) **The Successful Bidder's Security** will be retained until the Contract is signed and the required Performance and Payment Bonds have been furnished. If any bidder refuses to enter into a contract

within 30 days or fails to furnish the required bonds, TexBuy will retain the Bid Security as liquidated damages, but not as a penalty.

- (c.) **Performance Bonds** when required by Texas Law, shall be furnished by the successful bidder in an amount equal to one hundred percent (100%) of the total amount of the contract sum, underwritten by such Surety Company as the Participating Agency may approve, conditioned upon the faithful performance of the work in accordance with the plans, specifications, and contract documents. Said bond shall be solely for the protection of the Participating Agency.
 - (d.) **Payment Bonds** when required by Texas Law shall be furnished by the successful bidder, in the amount of the contract, solely for the protection of all claimants supplying labor and material as hereinafter defined, in the prosecution of the work provided in said contract, for the use of each claimant.
 - (e.) **Prevailing Wage** must be paid to any contractors or subcontractors or their employees or agents in performing any work under the awarded bid.
 - (f.) **Criminal History Background Checks** in accordance with Texas Education Code §22.0834 shall be required should any employee or agent of a contractor awarded a bid have “continuing duties related to the contracted services” with a school district and that employee or agent will have “direct contact with students” (as those terms are defined in 19 Texas Administrative Code 153.1101).
- (3) **Insurance:** The Contractor shall file with the Participating Agency’s designee, Insurance Certificates, as described herein, evidencing the coverage required, and shall be supplied within ten (10) calendar days after receipt of the written “Notice of Award”. In no instance shall the Contractor begin work prior to the filing of the insurance requirements. Failure to do so shall be grounds to void the contract. The Participating Agency’s designee shall be given ten (10) days notice prior to the cancellation or change of any of the required insurance coverage. The Participating Agency shall be named as Certificate Holder.
- (a.) Contractor’s Liability Insurance: Produce and maintain in force the following kinds of insurance of companies acceptable to the Owner. Minimum Limits of Liability are stated.

Contractor’s Liability Insurance:

Employer’s Insurance Workers’ Compensation—Statutory Employer’s Liability

Bodily Injury by Accident Each Occurrence—\$100,000.00

Bodily Injury by Disease Each Employee—\$100,000.00

Policy Limit—\$500,000.00

Commercial General Liability -Combined Limits of Bodily and Personal Injury and Property Damage:

Single Limit—\$500,000.00

Unimpaired Aggregate—\$500,000.00

Comprehensive Automobile Liability - Including non-ownership, hired and owned vehicle coverage:

Bodily Damage Each Person—\$250,000.00

Each Occurrence—\$500,000.00

Property Damage Each Occurrence—\$250,000.00

(b.) Owner's Insurance: Carry and pay for Owner's Protective Liability Insurance in the same amounts as specified above for the Contractor's General Liability. Name the Architect, Engineers, and Consultants as additional insured if applicable.

(c.) Comprehensive Catastrophic Liability: excess over the above liability policies in the amount of \$2,000,000.00 each occurrence. (Combined Limit)

D. Procedure for Processing Orders

- (1) Purchase orders are issued by participating agencies to the Contractor.
- (2) "Automated contracts" may be negotiated with TexBuy that provide for purchase orders to be sent directly to the Contractor with reports of usage submitted periodically to TexBuy.
- (3) Contractors deliver goods/services directly to the participating agency and then invoice the participating agency. The Contractor receives payment directly from the participating agency.
- (4) TexBuy shall receive quarterly reports from the Contractor reflecting total sales made through the TexBuy contract with the Contractor. The Contractor shall remit payment of their participation fee up to two percent (2%) to TexBuy at net thirty-day (30) terms.

E. Members Purchasing Under the Agency

TexBuy is operated by Region 16 Education Service Center, Amarillo, Texas and is available for use by all public and private schools, colleges, universities, cities, counties and other government agencies in the State of Texas.

24. Virginia, Fairfax County Public Schools

Additional Agency Terms and Conditions that apply to all categories

AUTHORITY-The Purchasing Agent has the sole responsibility and authority for negotiating, placing and when necessary modifying every solicitation, contract and purchase order (except for capital construction projects) issued by the County of Fairfax. In the discharge of these responsibilities, the Purchasing Agent may be assisted by assigned Buyers. Unless specifically delegated by the County Purchasing Agent, no other County officer or employee is authorized to order supplies or services, enter into purchase negotiations or contracts, or in any way obligate the government of the County of Fairfax for indebtedness. Any purchase ordered or contract made which is contrary to these provisions and authorities shall be of no effect and void and the County shall not be bound thereby.

NOTE: Fairfax County does not discriminate against faith-based organizations, in accordance with the *Code of Virginia*, § 2.2-4343.1, or against a Bidder or Bidder because of race, religion, color, sex, national origin, age, disability, or any other basis prohibited by state law relating to discrimination in employment in the performance of its procurement activity.

GENERAL

1. DEFINITIONS-

AGENCY: Any Department, Agency, Authority, Commission, Board or other unit in the Administrative Service of the County.

BIDDER/BIDDER: Any individual, company, firm, corporation, partnership or other organization bidding on solicitations issued by the Purchasing Agent and offering to enter into contracts with the County. The term "Bidder" will be used throughout this document and shall be construed to mean "Bidder" where appropriate.

CONTRACTOR: Any individual, company, firm, corporation, partnership or other organization to whom an award is made by the County.

COUNTY: County of Fairfax.

GOODS: All material, equipment, supplies, printing, and automated data processing/information technology hardware and software.

PURCHASING AGENT: The Purchasing Agent employed by the Board of Supervisors of Fairfax County, Virginia.

SERVICES: Any work performed by an independent Contractor wherein the service rendered does not consist primarily of acquisition of equipment or materials, or the rental of equipment, materials and supplies.

STATE: Commonwealth of Virginia.

- 2. FUNDING-**A contract shall be deemed binding only to the extent of appropriations available to each Agency for the purchase of goods and services.
- 3. CONTRACT ALTERATIONS-**No alterations in the terms of a contract shall be valid or binding upon the County unless made in writing and signed by the Purchasing Agent or his or her authorized agent.
- 4. SUBLETTING OF CONTRACT OR ASSIGNMENT OF CONTRACT FUNDS-**It is mutually understood and agreed that the Contractor shall not assign, transfer, convey, sublet or otherwise dispose of his or her contractual duties to any other person, firm or corporation, without the previous written consent of the Purchasing Agent. If the Contractor desires to assign his or her right to payment of the contract, Contractor shall notify the Purchasing Agent immediately, in writing, of such assignment of right to payment. In no case shall such assignment of contract relieve the Contractor from his or her obligations or change the terms of the contract.
- 5. NEW GOODS, FRESH STOCK-**All Contractors, unless otherwise specifically stated, shall provide new commodities, fresh stock, latest model, design or pack.
- 6. INSPECTION-ACCEPTANCE-**For determining acceptance of supplies in accordance with the provisions of the prompt payment discount paragraph, inspection and acceptance shall be accomplished only after examination (including testing) of supplies and services to determine whether the supplies and services conform to the contract requirements. Acceptance shall occur only after receipt and inspection provided such inspection, as appropriate, is accomplished within a reasonable time.
DELIVERY/SERVICE FAILURES-Failure of a Contractor to deliver goods or services within the time specified, or within reasonable time as interpreted by the Purchasing Agent, or failure to make replacements/corrections of rejected articles/services when so requested, immediately or as directed by the Purchasing Agent, shall constitute authority for the Purchasing Agent to purchase in the open market articles/services of comparable grade/quality to replace the services, articles rejected, and/or not delivered. On all such purchases, the Contractor shall reimburse the County, within a reasonable time specified by the Purchasing Agent, for any expense incurred in excess of contract prices. Such purchases shall be deducted from the contract quantities if applicable. Should public necessity demand it, the County reserves the right to use or consume articles delivered or services performed which are substandard in quality, subject to an adjustment in price to be determined by the Purchasing Agent.
- 7. GUARANTEES & WARRANTIES-**All guarantees and warranties required shall be furnished by the Contractor and shall be delivered to the Purchasing Agent before final payment on the contract is made. Unless otherwise stated, manufacturer's standard warranty applies.
- 8. INSPECTIONS-**Inspection and acceptance of materials or supplies will be made after delivery at destinations herein specified unless otherwise stated. If inspection is made after delivery at destination herein specified, the County will bear

the expense of inspection except for the value of samples used in case of rejection. Final inspection shall be conclusive except in regard to latent defects, fraud or such gross mistakes as to amount to fraud. Final inspection and acceptance or rejection of the materials or supplies will be made as promptly as practicable, but failure to inspect and accept or reject materials or supplies shall not impose liability on the County for such materials or supplies as are not in accordance with the specifications.

9. **POINT OF DESTINATION**-All materials shipped to the County must be shipped F.O.B. DESTINATION unless otherwise stated in the contract or purchase order. The materials must be delivered to the "Ship to" address indicated on the purchase order.
10. **ADDITIONAL CHARGES**-Unless bought F.O.B. "shipping point" and Contractor prepays transportation, no delivery charges shall be added to invoices except when express delivery is authorized and substituted on orders for the method specified in the contract. In such cases, difference between freight or mail and express charges may be added to invoice.
11. **TERMINATION OF CONTRACTS**-Contracts will remain in force for full periods specified and/or until all articles ordered before date of termination shall have been satisfactorily delivered and accepted and thereafter until all requirements and conditions shall have been met, unless:
 - a. Terminated prior to expiration date by satisfactory deliveries of entire contract requirements, or upon termination by the County for Convenience or Cause.
 - b. Extended upon written authorization of the Purchasing Agent and accepted by Contractor, to permit ordering of unorderd balances or additional quantities at contract prices and in accordance with contract terms.
12. **TERMINATION FOR CONVENIENCE**-A contract may be terminated in whole or in part by the County in accordance with this clause whenever the County Purchasing Agent shall determine that such a termination is in the best interest of the County. Any such termination shall be effected by delivery to the Contractor at least five (5) working days prior to the termination date of a Notice of Termination specifying the extent to which performance shall be terminated and the date upon which termination becomes effective. An equitable adjustment in the contract price shall be made for completed service, but no amount shall be allowed for anticipated profit on unperformed services.
13. **TERMINATION OF CONTRACT FOR CAUSE**-
 - a. If, through any cause, the Contractor shall fail to fulfill in a timely and proper manner his or her obligations under this contract, or if the Contractor shall violate any of the covenants, agreements, or stipulations of this contract, the County shall thereupon have the right to terminate, specifying the effective date thereof, at least five (5) days before the effective date of such termination. In such event all finished or unfinished documents, data, studies, surveys, drawings, maps, models, and reports prepared by the Contractor under the contract shall, at the option of the County, become its property and the Contractor shall be entitled to receive just and equitable compensation for any satisfactory work completed on such documents.
14. Notwithstanding the above, the Contractor shall not be relieved of liability to the County for damages sustained by the County by virtue of any breach of contract by the Contractor for the purpose of set off until such time as the exact amount of damages due to the County from the Contractor is determined.
15. **CHANGES**-Should it become proper or necessary in the execution of this contract to make any change in design, or to make any alterations which will increase the expense, the Purchasing Agent shall determine an equitable adjustment. No payment shall be made to the Contractor for any extra material or services, or of any greater amount of money than stipulated to be paid in the contract, unless some changes in or additions to the contract requiring additional outlay by the Contractor shall first have been expressly authorized and ordered in writing by contract amendment or otherwise furnished by the Purchasing Agent.
16. **GENERAL GUARANTY**-Contractor agrees to:
 - a. Save the County, its agents and employees harmless from liability of any nature or kind for the use of any copyrighted or uncopyrighted composition; secret process, patented or unpatented; invention; article or appliance furnished or used in the performance of a contract for which the Contractor is not the patentee, assignee, licensee or owner.
 - b. Protect the County against latent defective material or workmanship and to repair or replace any damages or marring occasioned in transit or delivery.
 - c. Furnish adequate protection against damage to all work and to repair damages of any kind to the building or equipment, to his or her own work or to the work of other Contractors, for which his or her workers are responsible.
 - d. Pay for all permits, licenses and fees and give all notices and comply with all laws, ordinances, rules and regulations of the County.
 - e. Protect the County from loss or damage to County owned property while it is in the custody of the Contractor.
17. **SERVICE CONTRACT GUARANTY**-Contractor agrees to:
 - a. Furnish services described in the solicitation and resultant contract at the times and places and in the manner and subject to conditions therein set forth provided that the County may reduce the said services at any time.
 - b. Enter upon the performance of services with all due diligence and dispatch, assiduously press to its complete performance, and exercise therein the highest degree of skill and competence.
 - c. All work and services rendered in strict conformance to all laws, statues, and ordinances and the applicable rules,

regulations, methods and procedures of all government boards, bureaus, offices and other agents.

- d. Allow services to be inspected or reviewed by an employee of the County at any reasonable time and place selected by the County. Fairfax County shall be under no obligation to compensate Contractor for any services not rendered in strict conformity with the contract.

Stipulate that the presence of a County Inspector shall not lessen the obligation of the Contractor for performance in accordance with the contract requirements, or be deemed a defense on the part of the Contractor for infraction thereof. The Inspector is not authorized to revoke, alter, enlarge, relax, or release any of the requirements of the contract documents. Any omission or failure on the part of the Inspector to disapprove or reject any work or material shall not be construed to be an acceptance of any such defective work or material. Notification of an omission or failure will be documented by the Purchasing Agent.

- 18. INDEMNIFICATION**-Contractor shall indemnify, keep and save harmless the County, its agents, officials, employees and volunteers against claims of injuries, death, damage to property, patent claims, suits, liabilities, judgments, cost and expenses which may otherwise accrue against the County in consequence of the granting of a contract or which may otherwise result therefrom, if it shall be determined that the act was caused through negligence or error, or omission of the Contractor or his or her employees, or that of the Subcontractor or his or her employees, if any; and the Contractor shall, at his or her own expense, appear, defend and pay all charges of attorneys and all costs and other expenses arising therefrom or incurred in connection therewith; and if any judgment shall be rendered against the County in any such action, the Contractor shall, at his or her own expense, satisfy and discharge the same. Contractor expressly understands and agrees that any performance bond or insurance protection required by this contract, or otherwise provided by the Contractor, shall in no way limit the responsibility to indemnify, keep and save harmless and defend the County as herein provided.

- 19. NON-DISCRIMINATION**-During the performance of this contract, the Contractor agrees as follows:

- a. The Contractor will not discriminate against any employee or applicant for employment because of race, religion, color, sex, national origin, age, disability, or other basis prohibited by state law relating to discrimination in employment, except where there is a bona fide occupational qualification reasonably necessary to the normal operation of the Contractor. The Contractor agrees to post in conspicuous places, available to employees and applicants for employment, notices setting forth the provisions of this non-discrimination clause.
- b. The Contractor, in all solicitations or advertisements for employees placed by or on behalf of the Contractor, will state that such Contractor is an equal opportunity employer.
- c. Notices, advertisements and solicitations placed in accordance with federal law, rule or regulation shall be deemed sufficient for the purpose of meeting the requirements of this section.
- d. The Contractor will include the provisions of the foregoing paragraphs a, b, and c above in every subcontract or purchase order of over \$10,000 so that the provisions will be binding upon each Subcontractor or vendor.
- e. Contractor and Subcontractor hereunder shall, throughout the term of this contract, comply with the Human Rights Ordinance, Chapter 11 of the Code of the County of Fairfax, Virginia, as reenacted or amended.

- 20. DRUG FREE WORKPLACE**-During the performance of a contract, the Contractor agrees to (i) provide a drug-free workplace for the Contractor's employees; (ii) post in conspicuous places, available to employees and applicants for employment, a statement notifying employees that the unlawful manufacture, sale, distribution, dispensation, possession, or use of a controlled substance or marijuana is prohibited in the Contractor's workplace and specifying the actions that will be taken against employees for violations of such prohibition; (iii) state in all solicitations or advertisements for employees placed by or on behalf of the Contractor that the Contractor maintains a drug-free workplace; and (iv) include the provisions of the foregoing clauses in every subcontract of over \$10,000, so that the provisions will be binding upon each Subcontractor or vendor. For the purposes of this section, "drug-free workplace" means a site for the performance of work done in conjunction with a specific contract awarded to a Contractor in accordance with this section, the employees of whom are prohibited from engaging in the unlawful manufacture, sale, distribution, dispensation, possession or use of any controlled substance or marijuana during the performance of the contract.

- 21. OFFICIALS NOT TO BENEFIT**-

- a. Each Bidder or Bidder shall certify, upon signing a bid or proposal, that to the best of his or her knowledge no Fairfax County official or employee having official responsibility for the procurement transaction, or member of his or her immediate family, has received or will receive any financial benefit of more than nominal or minimal value relating to the award of this contract. If such a benefit has been received or will be received, this fact shall be disclosed with the bid or proposal or as soon thereafter as it appears that such a benefit will be received. Failure to disclose the information prescribed above may result in suspension or debarment, or rescission of the contract made, or could affect payment pursuant to the terms of the contract.
- b. Whenever there is reason to believe that a financial benefit of the sort described in paragraph "a" has been or will be received in connection with a bid, proposal or contract, and that the Contractor has failed to disclose such benefit or has inadequately disclosed it, the County Executive, as a prerequisite to payment pursuant to the contract, or at any other time, may require the Contractor to furnish, under oath, answers to any interrogatories related to such possible

benefit.

- c. In the event the Bidder or Bidder has knowledge of benefits as outlined above, this information should be submitted with the bid or proposal. If the above does not apply at time of award of contract and becomes known after inception of a contract, the Bidder or Bidder shall address the disclosure of such facts to the Fairfax County Purchasing Agent, 12000 Government Center Parkway, Suite 427, Fairfax, Virginia 22035-0013. Relevant Invitation/Request for Proposal Number (see cover sheet) should be referenced in the disclosure.

LICENSE REQUIREMENT-All firms doing business in Fairfax County, shall obtain a license as required by Chapter 4, Article 7, of The Code of the County of Fairfax, Virginia, as amended, entitled "Business, Professional and Occupational Licensing (BPOL) Tax." Questions concerning the BPOL Tax should be directed to the Department of Tax Administration, telephone (703) 222-8234 or visit: http://www.fairfaxcounty.gov/dta/business_tax.htm. The BPOL Tax number must be indicated in the space provided on the Cover Sheet, "Fairfax License Tax No." when appropriate.

- 22. REGISTERING OF CORPORATIONS**-Any foreign corporation transacting business in Virginia shall secure a certificate of authority as required by Section 13.1-757 of the Code of Virginia, from the State Corporation Commission, Post Office Box 1197, Richmond, Virginia 23209. The Commission may be reached at (804) 371-9733. The consequences of failing to secure a certificate of authority are set forth in Virginia Code Section 13.1-758.

- 23. COVENANT AGAINST CONTINGENT FEES**-The Contractor warrants that no person or selling agency has been employed or retained to solicit or secure this contract upon an agreement or understanding for a commission, percentage, brokerage, or contingent fee, except bona fide employees or bona fide established commercial or selling agencies maintained by the Contractor for the purpose of securing business. For violation of this warranty, the County shall have the right to terminate or suspend this contract without liability to the County or in its discretion to deduct from the contract price or consideration, or otherwise recover, the full amount of such commission, percentage, brokerage, or contingent fee.

24. OFFICE OF SMALL BUSINESS-

- a. It is the policy of the County of Fairfax as declared by the Fairfax County Board of Supervisors' adoption of a Small and Minority Business Enterprise Program, April 6, 1981, that Fairfax County and its employees undertake every effort to increase opportunity for utilization of small or minority businesses in all aspects of procurement to the maximum extent feasible.
- b. In connection with the performance of this contract, the Contractor agrees to use his or her best effort to carry out this policy and to insure that small and minority businesses shall have the maximum practicable opportunity to compete for subcontract work under this contract consistent with the efficient performance of this contract.
- c. As used in this contract the term "small business" means a corporation, partnership, or sole proprietorship, or other legal entity formed for the purpose of making a profit, which is independently owned and operated, has either fewer than 100 employees, or less than \$1,000,000 in annual receipts.
- d. As used in this contract, the term "minority business" means a business enterprise that is at least 51 percent owned and controlled by a minority person or persons. Such persons include African Americans, Hispanic Americans, Asian Americans, American Indians, Eskimos and Aleuts; women regardless of race or ethnicity; and persons with a physical impairment that substantially limits one or more of the major life activities of such individuals, a record of such impairment, or who are regarded as having such an impairment.
- e. Contractors may rely on oral or written representations by Subcontractors regarding their status as small and/or minority business enterprises in lieu of independent investigation.
- f. Where Federal grants or monies are involved it is the policy of Fairfax County, through its agents and employees, to comply with the requirements set forth in the U.S. Office of Management and Budget Circular No. A-102, uniform administrative requirements for Grants and Cooperative Agreements with State and Local Governments, as they pertain to small and minority business utilization.

PAYMENTS

- 25. TAX EXEMPTION**-The County is exempt from the payment of any federal excise or any Virginia sales tax. The price bid must be net, exclusive of taxes. However, when under established trade practice any federal excise tax is included in the list price, a Bidder may quote the list price and shall show separately the amount of federal tax, either as a flat sum or as a percentage of the list price, which shall be deducted by the County. Fairfax County's Federal Excise Tax Exemption Number is 54-74-0127K. Contractors located outside the Commonwealth of Virginia are advised that when materials are picked up by the County at their place of business, they may charge and collect their own local/state sales tax. Materials used in the performance of construction contracts are subject to Virginia Sales/Use Tax as described in Section 630-10-27J of the Virginia Retail Sales and Use Tax Regulations.

- 26. PAYMENT**-Payment shall be made after satisfactory performance of the contract, in accordance with all of the provisions thereof, and upon receipt of a properly completed invoice. Fairfax County reserves the right to withhold any or all payments or portions thereof for Contractor's failure to perform in accordance with the provision of the contract or any modifications thereto.

- 27. PARTIAL PAYMENTS-**Unless otherwise specified, partial payments will be made upon acceptance of materials or services so invoiced if in accordance with completion date. However, up to 5 percent (5%) of the value of the entire order may be retained until completion of contract.
- 28. PAYMENT FOR EQUIPMENT, INSTALLATION, AND TESTING-**When equipment requires installation (which shall also be interpreted to mean erection and/or setting up or placing in position, service, or use) and test, and where such installation or testing is delayed, payment may be made on the basis of 50% of the contract price when such equipment is delivered on the site. A further allowance of 25% may be made when the equipment is installed and ready for test. The balance shall be paid after the equipment is tested and found to be satisfactory. If the equipment must be tested, but installation is not required to be made by the Contractor or if the equipment must be installed but testing is not required, payment may be made on the basis of 75% at the time of delivery and the balance shall be paid after satisfactory test or installation is completed.

REMEDIES

29. INELIGIBILITY-

- a. Any person or firm suspended or debarred from participation in County procurement shall be notified in writing by the County Purchasing Agent.
 1. The Notice of Suspension shall state the reasons for the actions taken and such decision shall be final unless the person or firm appeals within thirty (30) days of receipt of the Notice by instituting legal action as provided in the Code of Virginia.
 2. The Notice of Debarment shall state the reasons for the actions taken and the decision shall be final unless the person or firm appeals within thirty (30) days of receipt of the notice by instituting legal action as provided in the Code of Virginia.
- b. The County Purchasing Agent shall have the authority to suspend or debar a person or firm from bidding on any contract for the causes stated below:
 1. Conviction for commission of a criminal offense as an incident to obtaining or attempting to obtain a public or private contract or subcontract, or in the performance of such contract or subcontract;
 2. Conviction under state or federal statutes of embezzlement, theft, forgery, bribery, falsification or destruction of records, receiving stolen property, or any other offense indicating a lack of business integrity or business honesty which currently, seriously, and directly affects responsibility as a County Contractor;
 3. Conviction under the state or federal antitrust statutes arising out of the submission of bids or proposals;
 4. Violation of contract provisions, as set forth below, of a character which is regarded by the County Purchasing Agent to be so serious as to justify suspension or debarment action:
 - (a) failure without good cause to perform in accordance with the specifications or within the time limit provided in the contract; or
 - (b) a recent record of failure to perform or of unsatisfactory performance in accordance with the terms of one or more contracts; provided, that failure to perform or unsatisfactory performance caused by acts beyond the control of the Contractor shall not be considered to be a basis for suspension or debarment;
 5. Any other cause the County Purchasing Agent determines to be so serious and compelling as to affect responsibility as a Contractor, such as debarment by another governmental entity for any cause listed herein, or because of prior reprimands;
 6. The Contractor has abandoned performance or been terminated for default on any other Fairfax County project;
 7. The Contractor is in default on any surety bond or written guarantee on which Fairfax County is an obligee.
- c. If, upon appeal, it is determined that the action taken by the County Purchasing Agent was arbitrary or capricious, or not in accordance with the Constitution of Virginia, statutes or regulations, the sole relief available to the person or firm shall be restoration of eligibility. The person or firm may not institute legal action until all statutory requirements have been met.

30. CONTRACTUAL DISPUTES-

- a. Any dispute concerning a question of fact as a result of a contract with the County which is not disposed of by agreement shall be decided by the County Purchasing Agent, who shall reduce his decision to writing and mail or otherwise forward a copy thereof to the Contractor within thirty (30) days. The decision of the County Purchasing Agent shall be final and conclusive unless the Contractor appeals within six (6) months of the date of the final written decision by instituting legal action as provided in the Code of Virginia. A Contractor may not institute legal action, prior to receipt of the public body's decision on the claim, unless the public body fails to render such decision within the time specified.
- b. Contractual claims, whether for money or other relief, shall be submitted in writing no later than sixty days after final payment; however, written notice of the Contractor's intention to file such claim shall have been given at the time

of the occurrence or beginning of the work upon which the claim is based. Nothing herein shall preclude a contract from requiring submission of an invoice for final payment within a certain time after completion and acceptance of the work or acceptance of the goods. Pendency of claims shall not delay payment of amounts agreed due in the final payment.

31. LEGAL ACTION-No Bidder, Bidder, potential Bidder or Bidder, or Contractor shall institute any legal action until all statutory requirements have been met.

C - Member Purchasing

32. COOPERATIVE PURCHASING-The County may participate in, sponsor, conduct or administer a cooperative procurement agreement on behalf of or in conjunction with one or more other public bodies, or public agencies or institutions or localities of the several states, of the United States or its territories, or the District of Columbia, for the purpose of combining requirements to increase efficiency or reduce administrative expenses in any acquisition of goods and services. Except for contracts for architectural and engineering services, a public body may purchase from another public body's contract even if it did not participate in the request for proposal (RFP) or invitation for bid (IFB), if the RFP or IFB specified that the procurement was being conducted on behalf of other public bodies. Nothing herein shall prohibit the assessment or payment by direct or indirect means of any administrative fee that will allow for participation in any such arrangement. As authorized by the United States Congress and consistent with applicable federal regulations, and provided the terms of the contract permit such purchases, any county, city, town, or school board may purchase goods and nonprofessional services from a U.S. General Services Administration contract or a contract awarded by any other agency of the U.S. government. Bidders are advised that the *resultant* contract(s) may be extended, with the authorization of the Bidder, to other public bodies, or public agencies or institutions of the United States to permit their use of the contract at the same prices and/or discounts and terms of the resulting contract. If any other public body decides to use the final contract, the Contractor(s) must deal directly with that public body concerning the placement of orders, issuance of purchase orders, contractual disputes, invoicing and payment. The County of Fairfax acts only as the "Contracting Agent" for these public bodies. It is the Contractors responsibility to notify the public body(s) of the availability of the contract(s). Other public bodies desiring to use this contract will need to make their own legal determinations as to whether the use of this contract is consistent with their laws, regulations, and other policies. Each public body has the option of executing a separate contract with the Contractor(s). Public bodies may add terms and conditions required by statute, ordinances, and regulations, to the extent that they do not conflict with the contracts terms and conditions. If, when preparing such a contract, the general terms and conditions of a public body are unacceptable to the Contractor, the Contractor may withdraw its extension of t

25. Washington, King County Directors' Association (KCDA)

(General Contracts and Construction/Public Works Projects)

A. KCDA Additional General Terms and Conditions

General Intent: KCDA may participate in all or any part of the goods and services listed in this IFB, upon completion of contracts currently in effect, whichever is deemed in the best interest of KCDA members. KCDA cannot be restricted by the successful bidder from choosing which parts of these contracts to use.

Both the Contractor and KCDA member using this Contract agree that it is the member's responsibility to perform due diligence as to the legality of their usage of this contract. In this regard, KCDA suggests that, at a minimum, Contractor and member considering such usage consult with their legal counsel before doing so.

Advertising/Marketing:

KCDA requires all vendors to develop a marketing program to include printed, web-based, e-mail, telemarketing and other methods approved by KCDA.

All promotional marketing materials must have the prior approval of KCDA before distribution and must include the KCDA logo and other contract information.

KCDA staff will work jointly with all vendors and their representatives to market the AEPA contracts to KCDA members and prospective members. Vendors may be requested to make joint presentations to KCDA or its members in either a one to one or a group setting. Some group presentations may be done in conjunction with other vendors.

Displaying exhibits at various statewide conferences are encouraged. Contractor agrees to make available KCDA supplied brochures or other promotional materials at these events. Contractor will provide KCDA with scheduled exhibit dates in advance.

Contractor agrees to insert the approved KCDA logo, web address and contact information on the Contractor's website promoting and providing a link to the KCDA website. Contractor will also provide KCDA with text, links and logos to be posted on the KCDA website.

Assignment:

Contractor shall not subcontract, assign, transfer, convey, sublet or otherwise dispose of contractual duties to any other person, firm or corporation without the previous written consent of KCDA and any member that has an outstanding open purchase order or financing arrangement. In no case shall such assignment of Contract relieve the Contractor from obligations or change the terms of the Contract.

Cancellation/Default/Termination:

KCDA reserves the right to cancel the whole or any part of this contract due to the failure by the Contractor to carry out any obligation, term or condition of the contract. KCDA will issue written notice to the contractor for acting or failing to act in any of the following:

- The Contractor fails to adequately perform the services set forth in the contract
- The Contractor fails to make progress in the performance of the contract and/or gives KCDA reason to believe the Contractor will not or cannot perform to the requirements of the contract
- The Contractor fails to observe any of the terms and conditions of the contract
- The Contractor fails to pay any applicable administrative fees.
- The Contractor fails to follow the established procedure for purchase orders, invoices and receipt of funds as stipulated by KCDA.

If the contract is to be terminated KCDA shall do the following:

Step 1 – Issue a warning Letter of Concern outlining the violations and length of time to correct the problem(s). Upon receipt of the letter, the Contractor shall have ten (10) business days to provide a satisfactory response to KCDA. Failure on the part of the Contractor to address adequately all issues of concern may result in contract cancellation.

Step 2 – Issue a letter of intent to cancel the contract if the problems(s) are not resolved by the date specified.

Step 3 – Issue a letter to terminate the contract.

Compliance with Laws

In addition to any requirements set forth herein, vendor shall comply with all applicable state, federal and local laws, rules, regulations and ordinances.

Contract Amendments:

KCDA reserves the right to amend the contract resulting from state law changes or internal boilerplate changes due to state law changes. Contractors/Vendors will be sent written notification of the changes.

Employees who have been Convicted of Crimes Against Children:

The Contractor, or any subcontractors, shall not utilize any employee at a school site or allow any contact between school children and any employee when an employee has plead guilty to or been convicted of any felony crime involving the physical neglect of a child under Chapter 9A.42RCW, the physical injury or death of a child under Chapter 9A.32 or 9A.36RCW (except motor vehicle violations under Chapter 46.61 RCW), sexual exploitation of a child under Chapter 9A.444 RCW where a minor is the victim, promoting prostitution of a minor under Chapter 9A.88 RCW, the sale or purchase of a minor child under 9A.88 RCW, or violation of similar laws of another jurisdiction.

Contractors/Vendors who have regularly scheduled unsupervised access to children, and/or who hire employees who will have regularly scheduled unsupervised access to children, shall perform a record check through the Washington State Patrol criminal identification system under RCW 43.43.830-43.43.834, 10.97.0303 and 10.97.050, and through the Federal Bureau of Investigation before hiring the employee. The record check shall include a fingerprint check using a complete Washington State criminal identification fingerprint card. The Contractor shall provide a copy of the record to the person applying for employment to the school location. If the Contractor or applicant has had a record check within the previous two years, the Contractor may waive the requirement. The Contractor shall determine whether the applicant or the Contractor shall pay costs associated with the record check.

In addition, pursuant to RCW 9.96A.020 and 1993 Chapter Law 71, a person is disqualified from employment by school districts, and their Contractor from hiring employees who will have regularly scheduled unsupervised access to children because of a prior guilty plea or conviction of a felony crime specified under RCW 28A.400.322, or a violation of similar laws of another jurisdiction, even if the time elapsed since the guilty plea or conviction is ten years or more.

Governing Law and Venue/Legal Litigation:

All applicable local, state and federal laws and regulations will apply to any purchases of equipment, service or public works in any of the states KCDA currently services, as well as any other non-AEPA states where members may be added to KCDA membership throughout the term of these contracts. The laws of the State of Washington govern the Contract. Each and every provision of law and clause required by law to be included in the Contract shall be deemed to be inserted herein and the Contract shall be read and enforced as though it were included. If through mistake or otherwise any such provision is not included, or is not currently included, then upon application of either party the Contract shall be physically amended to make such inclusion or correction. Venue for any litigation arising out of or related to the Contract shall take place in the State of Washington.

Hazardous Materials:

If any hazardous chemicals/materials are supplied under a contract/purchase order arising out of this solicitation, a Safety Data Sheet (SDS) shall accompany the delivery of any hazardous chemicals/materials supplied by the vendor. All SDA sheets shall be sent to KCDA and the KCDA member. Any products not appropriately labeled will be refused and the vendor will be responsible for additional freight charges.

Indemnification/Hold Harmless:

The Contractor agrees to defend, indemnify and hold harmless KCDA and the member agency, and their respective officers, officials, employees and volunteers from any and all claims, injuries, damages, losses or suits including attorney fees arising out of or resulting from the acts, errors or omissions in performance of this Agreement, except for injuries and damages caused by the sole negligence of KCDA or the member agency. Should a court of competent jurisdiction determine that this Agreement is subject to RCW 4.24.115, then, in the event of liability for damages arising out of bodily injury to persons or damages to property caused by or resulting from the concurrent negligence of the Contractor, KCDA or the member agency and their respective officers, officials, employees, and volunteers, the Contractor's liability, including the duty and cost to defend, hereunder shall be only to the extent of the Contractor's negligence. It is further specifically and expressly understood that the indemnification provided herein constitutes the Contractor's waiver of immunity under Industrial Insurance, Title 51 RCW, solely for the purpose of this indemnification. Use of this contract certifies that the waiver of immunity specified by this provision was mutually negotiated by the parties. The provisions of this section shall survive the expiration or termination of the Agreement.

Independent Contractor:

The Contractor shall not be held or deemed in any way to be the agent or employee of KCDA and /or a KCDA member. It is the intention of the parties that the Contractor shall be and is to be considered an independent Contractor.

Minority and Women Owned Businesses:

KCDA encourages all minority and women owned businesses to participate in the bid process. Washington State law does not allow KCDA to provide any financial advantage for minority and women owned businesses who participate, however, KCDA believes that a diverse range of suppliers benefits all.

Quality of Goods:

Bidder shall bid and provide new (not used or refurbished) items only. Seller warrants all supplies, materials and equipment and services covered by a contract/purchase order with KCDA or with a KCDA member will:

- (a) conform to the specifications, drawings, written instructions, samples, or descriptions;
- (b) be of good quality and workmanship;
- (c) be free of defects in design, materials and workmanship;
- (d) be merchantable;
- (e) be fit for particular purposes applicable to the design, function or use of the supplies, materials and equipment.

Taxes:

The KCDA Members and Associate Members are to be taxed.

Term of Contract:

The term of the agreement shall commence on the date of the award and continue as stipulated in the General Terms and Conditions, unless terminated, canceled or extended.

Use of Tobacco on School Districts/Public Agency Premises:

RCW 28A.210.310 prohibits the use of tobacco in any form on school district property. Smoking or other use of tobacco will not be permitted at the job site.

B. Procedure for Processing Orders Order Procedure

After entering into an agreement with KCDA, KCDA will confirm the directions for placement of orders with the Contractor, and will post directions on the KCDA website for both Contractor and members. These directions will also be posted on each awarded Contractors/Vendors website.

- Once the award is made to the Contractor, KCDA will inform members of the contract.
- At this point the Contractor may directly contact members or the member may contact the Contractor.
- A list of members, addresses and phone numbers is available to the Contractor upon request.
- Before a Contractor may enter into business with a KCDA member, they need to verify membership through the KCDA website, which can be viewed under Membership.

Invoicing/Reporting

- KCDA will contact Contractors/Vendors about invoicing procedures.
- KCDA is funded through a service fee paid to KCDA by the participating Contractors/Vendors. The service fee percentage is based upon the total sale of goods and services, including installation, if applicable. This fee shall be reflected in all price quotations under the KCDA agreement. The service fee will be 2%. Do not print the service fee as a separate line item on the quotation.
- The Contractor will compile an electronic quarterly report listing each purchase made by participating members. Within 30 days after each quarterly period the report will be sent to the e-mail address of the KCDA Purchasing Director, Thomas Kim, tkim@kcda.org and Director of Finance, Robert Payne rpayne@kcda.org
- These reports shall be in Microsoft Excel format and shall have file names that identify the Contractor and the quarterly period being reported. They shall include the following fields and allow for sorting on any of the fields: Date of order, name of member, item purchased, quantity, unit price, extended price, member PO #, Contractor order number.
- KCDA reserves the right to change the contact name of existing KCDA personnel administering the contract. If there are personnel changes, reports and payments will be sent to the new contact(s) specified.

C. Agencies Allowed to Purchase under KCDA

King County Director's Association (KCDA) is a member owned purchasing cooperative representing 295 Washington State school districts. In addition, KCDA provides purchasing and procurement services for more than 1,200 public agencies and political subdivisions in Washington and other states, including but not limited to Alaska, Idaho, and Montana. KCDA also provides purchasing services for accredited private K-12 schools in Washington State.

A listing of all KCDA members is available on the KCDA website, www.kcda.org.

D. KCDA Additional Terms & Conditions for Construction Products and Services

Contractor agrees that, in performance of the services required under this agreement, Contractor shall abide by all federal, state, local and Washington law and regulations that may apply to construction and public works. It is the responsibility of the Contractor to determine applicability and requirements of any such laws and to abide by them.

- **Bid Bond:** The bid must be accompanied by a bid bond using the KCDA form included in these contract provisions, issued by a surety licensed to do business in the State of Washington and made out to King County Directors Association in an amount not less than 5% of the amount of the bid as identified in Part B, Section 4 of the solicitation. A Power of Attorney must accompany the bid bond and must appoint the surety's true and lawful attorney-in-fact to make, execute, seal and deliver the bid guarantee bond. Failure to submit the required bid security with the Bid shall render the bid non-responsive and the bid shall be rejected.
- **Public Works:** State of Washington statute requires workers be paid prevailing wages when employed on public works projects and on public building service maintenance contracts. (RCW 39.04.010, RCW 39.12.010 and 020) It is the contractor's responsibility to be acquainted with and comply with State regulations regarding payment of prevailing wages on public works projects. Prevailing Wages are established by the Washington State Department of Labor and Industries and can be obtained on the web at <http://www.lni.wa.gov/TradesLicensing/PrevWage/WageRates/default.asp> or by contacting Labor and Industries at 360-902-5335. KCDA serves all counties in Washington State. The County in which the project is located will be identified once a member initiates a request for the service, and the effective wage rate to be applied to a specific project is to be based on the date of this bid during the original contract term, and if contract extensions are granted, the prevailing wage rate in effect at the time of the latest extension. A copy of the applicable prevailing wage rates are also available for viewing at the office of KCDA. Upon request KCDA will mail a hard copy of the applicable prevailing wages.
- **Application:** The Public Works Act regulates wages paid to workers, laborers and mechanics performing public work. It does not apply to work that is clerical, executive administrative or professional in nature. It does not apply to work of a secretary, engineer or administrator, unless they are performing construction work, alteration work, repair work, etc. Prevailing wage application depends on the work that is performed, regardless of the worker's job title. (RCW 39.12.020 and WAC 296-128-510 through 530). Definition: Public Works is all work, construction, alteration, repair or improvement that is executed at the cost of the state or any other local public agency. This includes, but is not limited to, demolition, remodeling, renovation, road construction, building construction, ferry construction and utilities construction. (RCW 39.04.010). Public Building Service Maintenance Contracts: Prevailing wages are also required on all public building service maintenance (janitorial) contracts. (RCW 39.12.020). **Contractors bidding a Public works project exceeding \$1,000,000.00 must declare who their HVAC, Plumbing and Electrical subcontractors will be and submit this information with bid documents in order for the bid to be responsive (RCW 39.30.060).** Such projects also have special considerations pertaining to prefabricated materials (RCW 39.04.370) and use of apprentices (39.04.320).
- **Reciprocity:** In accordance with RCW 39.04.380 any bidding process for public works in which a bid is received from a nonresident contractor from a state that provides a percentage bidding preference, a comparable percentage disadvantage must be applied to the bid of that nonresident contractor. This does not apply to public works procured pursuant to RCW 39.04.155, 39.04.280 or other procurement exempt from competitive bidding.
- **Prevailing Wage:** Definition: Prevailing Wage is the hourly wage, usual benefits and overtime, paid in the largest city in each county, to the majority of workers, laborers and mechanics. The rate is established by the Department of Labor and Industries for each trade and occupation employed in the performance of public work. If Federal funds are used, bidders must comply with provisions of Davis-Bacon Act.
- **Basic procedures:** A Statement of Intent to Pay Prevailing Wages and Affidavit of Wages Paid must be filed and approved for the contractor and all subcontractors. No payments can be made until all Contractors/Vendors have submitted an approved intent form. KCDA cannot release retainage until all Contractors/Vendors have an approved Affidavit of Wages Paid form certified by the Industrial Statistician. (RCW 39.12.030, 040, 042). Costs for filing shall be the responsibility of the Contractor. Once the work is successfully completed, KCDA will release 95% of the project cost and withhold 5% retainage for as dictated by law. The final 5% will be paid when the following is completed: acceptance of project completion to the satisfaction of the KCDA ordering member, followed by receipt of approved Affidavit of Wages Paid Forms, Releases from Washington State Department of Labor & Industries, Employment Security Department and the Department of Revenue.
- **Federally Funded Projects:** In addition to the Federal Requirements of Section III General Terms and Conditions, Davis-Bacon prevailing wage requirements apply to public works construction contracts of \$2000 or more when a project includes any federal funding of any amount. When there is a difference between applicable state and federal prevailing wages for a particular classification of labor, contractors and subcontractors are required to pay the higher of the two prevailing wages. Applicable federal prevailing wage determinations can be found at <http://www.wdol.gov/>. Contractors/Subcontractors must be knowledgeable and adhere to all federal prevailing wage requirements, including but not limited to paying workers weekly and providing certified weekly payrolls for the contractor and subcontractors of any tier as required in the Davis-Bacon Act and applicable U.S. Department

of Labor regulations. Falsification of any prevailing wage payroll records may subject the contractor or subcontractor to civil or criminal prosecution under section 1001 of Title 18 and section 231 of Title 31 of the United States Code. Contractor shall inform all subcontractors of the Davis-Bacon requirements and the prime contractor shall be responsible for the compliance by any subcontractor or lower tier subcontractor with all the contract clauses. Contractor must coordinate all requirements related to federal funded projects with the KCDA member Agency.

- **Responsible Bidder**

Before award, the bidder must meet the following state responsibility criteria and, if applicable, supplemental responsibility criteria to be considered a responsible bidder. The bidder is required to submit documentation demonstrating compliance with the criteria.

Low Responsible Bidder

A. State Responsibility Criteria. The Bidder must meet the following state responsibility criteria:

1. At the time of submittal of bid to AEPA, the contractor must hold a current Washington State Contractors License in the name of the company signing the bid. Failure to have the license prior to submitting the bid is a violation of chapter 18.27 RCW and is a gross misdemeanor.
2. Have a current Washington State Unified Business Identifier (UBI) number.
3. Not be disqualified from bidding on any public works contract under RCW 39.06.010 or 39.12.065(3).
4. If applicable:
 - a. Have Industrial Insurance (workers' compensation) coverage for the Bidder's employees working in Washington State, as required in Title 51 RCW;
 - b. Have a Washington State Employment Security Department number, as required in Title 50 RCW; and
 - c. Have a Washington State Department of Revenue state excise tax registration number, as required in Title 82 RCW.

B. Supplemental Bidder Responsibility Criteria. If supplemental criteria apply to this project, the criteria are included in "Attachment A." The Bidder may make a written request to modify any or all of the supplemental criteria. Modification of supplemental criteria shall be at KCDA's discretion. Any modifications to the supplemental criteria shall be made by addenda prior to bid opening.

Subcontractor Responsibility:

The contractor shall include the language of this section in each of its first tier subcontracts, and shall require each of its subcontractors to include the same language of this section in each of their subcontracts, adjusting only as necessary the terms used for the contracting parties. The requirements of this section apply to all subcontractors regardless of tier. At the time of subcontract execution, the Contractor shall verify that each of its first tier subcontractors meets the following bidder responsibility criteria:

1. At the time of bid submittal, have a current certification of registration in compliance with chapter 18.27 RCW.
2. Have a current Washington State Unified Business Identifier (UBI) number.
3. Not be disqualified from bidding on any public works contract under RCW 39.06.010 or 39.12.065(3).
4. If applicable:
 - a. Have Industrial Insurance (workers' compensation) coverage for the Bidder's employees working in Washington State, as required in Title 51 RCW;
 - b. Have a Washington State Employment Security Department number, as required in Title 50 RCW; and
 - c. Have a Washington State Department of Revenue state excise tax registration number, as required in Title 82 RCW
5. Have an electrical contractor license, if required by Chapter 19.28 RCW;
6. Have an elevator contractor license, if required by Chapter 70.87 RCW;

- **Bonds- Payment & Performance:**

The prime Contractor shall provide a Performance and Payment Bond at 100% of the contract price to the KCDA member with a copy to KCDA before work begins. The only exception is for contracts of thirty-five thousand (\$35,000) dollars or less. In this instance, at the option of the Contractor, the member may in lieu of the bond retain fifty percent of the contract amount for a period of thirty days after date of final acceptance, or until receipt of all necessary releases from the Department of Revenue and the Department of Labor and Industries and settlement of any liens filed under Chapter

60.28 RCW, whichever is later. The bond shall be issued by a surety company authorized to do business in the State of Washington and shall be on standard forms used for public projects (RCW 39.08.010) and as directed by the KCDA member. Performance and Payment bonds for KCDA members outside Washington must be provided by

companies licensed to provide bonds for public entities in the member's state.

- **Licenses:** The prime contractor shall possess and maintain in current status all federal, state, and local licenses, bonds, and permits required for the performance and delivery of any and all products and services offered in its response to the bid solicitation. Before submitting a bid, Bidders must hold a current, valid contractor's license as required in Washington. The contractor's license must be in the name of the legal entity submitting and signing the bid. A bidder may not substitute a contractor's license held by a subcontractor or joint venture. Bidders submitting bids in Washington State without a valid contractor's license in the name of the Bidder are in violation of RCW 18.27.010. It is the responsibility of the prime contractor to ensure any subcontractors performing under this contract hold and maintain appropriate licenses. The contractor shall verify that appropriate licenses are in place at the time of response to this bid. Copies of licenses must be submitted to the member prior to performing the work. The Contractor agrees to keep and ensure subcontractors keep any required license, permit or bond current and in compliance with Washington rules, regulations and statutes, as well as in states outside Washington in which contractor performs work under this contract. For work performed for any Washington State school district, public agency or municipality, the Contractor must comply with the bidder responsibility requirements of RCW 39.04.350 prior to the KCDA member awarding a contract. The contractor must verify the responsibility of all subcontractors used in accordance with RCW 39.06.020.
- **Permits:** The acquisition of all permits as well as any drawings needed to obtain those permits is the responsibility of the successful Contractor/Bidder unless otherwise acknowledged by the KCDA member.
- **Certificate of Insurance:** A certificate of insurance demonstrating current coverage of the types and amounts of insurance required by KCDA and the KCDA member must be provided to KCDA and the KCDA member prior to performance of any work. In addition, the Commercial General Liability policies must be endorsed to name KCDA and the KCDA member as additional insureds. Such policies must be further endorsed to provide that the insurance is primary as respects KCDA and the KCDA member, and that any other insurance maintained by KCDA and the KCDA member shall be excess and not contributing insurance with the Contractor's insurance. These endorsements must be provided along with the certificate of insurance. KCDA and the KCDA member must both approve the certificate of insurance and endorsements.
- **Acceptable Pricing Method:** KCDA is unable to accept Alternative Costing Method quotations except in certain limited instances, (i.e. sole source) in which KCDA and Contractor may mutually determine the Alternative Costing Method is acceptable. This will be the exception rather than the rule. RS Means or line item bid pricing is acceptable.
- **Progress Payments:** The Contractor shall be paid, upon submission of a proper Payment Request, the prices stipulated herein for work performed (less deductions, if any), in accordance with all payment and retainage instructions herein. Submitted Payment Requests must contain the following minimum information:
 - a. Contract Number
 - b. Bid item ID, bid quantity, unit, unit price and description as appropriate
 - c. Sales Tax as applicable

The Payment Request will be reviewed by the Member before payment is made. If the Member is in disagreement with the Payment Request, KCDA will issue a notice requesting a revised Payment Request. In accordance with RCW 51.12.050, KCDA reserves the right to deduct from the payment any outstanding industrial insurance premiums owed by the Contractor or Subcontractors.

- **Payment Retainage:** In accordance with RCW 60.28 a contract retainage of not to exceed five percent of the moneys earned by the contractor toward completion of a public improvement contract shall be withheld and reserved as a trust fund for the protection and payment of 1) the claims of any person arising under the contract, and 2) the state with respect to taxes imposed pursuant to Titles 50, 51 and 82 RCW which may be due from such contractor. Upon completion of a contract, the member agency shall notify the Department of Revenue, the Employment Security Department, and the Department of Labor and Industries of the completion of contracts over thirty-five thousand dollars. KCDA will issue payment on the retainage amount forty-five days after notice from the KCDA Member Agency that the contract has been accepted as complete or upon receipt of all necessary releases, whichever is later.



PURCHASING COOPERATIVE

BID BOND

KNOW ALL BY THESE PRESENTS, That we _____
Of _____

As principal, and _____

a corporation duly organized under the laws of the State of _____ and authorized to do business in the State of Washington, as surety, are held and firmly bond unto King County Directors Association in the full and penal sum of _____ for the work hereinafter described, for the payment of which, well and truly to be made, we bind our heirs, executors, administrators and assigns, and successors and assigns, firmly by these presents.

The conditions of this bond are such, that whereas the principal herein is herewith submitting his or its sealed proposal for the following, to wit:

Said bid and proposal, by reference thereto, being made a part hereof.

NOW, THEREFORE, If the said proposal bid by said principal be accepted, and the contract be awarded to said principal, and if said principal shall duly make and enter into and execute said contract and shall furnish bond as required by King County Directors Association within a period of ten (10) days from and after said award, exclusive of the day of such award, then this obligation shall be null and void, otherwise it shall remain and be in full force and effect.

IN TESTIMONY WHEREOF, The principal and surety have caused these present to be signed and sealed this _____
Day of _____.

By: _____

Principal

By: _____

Surety

Title: _____

Title: _____

Date: _____

Date: _____

26. West Virginia, West Virginia Regional Education Service Agencies Cooperative Purchasing

a. General Terms and Conditions that apply for all Categories:

i. Compliance with Laws/Forum Designation

Contractor shall comply with Federal, State, and Local Laws, Codes and Regulations while fulfilling the contract. It is the Contractor's responsibility to be aware of and comply with all state and local laws governing this procurement. Applicable laws, codes, and regulations (etc.) must be followed even if not specifically identified herein. The terms of the Agreement Addendum which is attached hereto and incorporated herein shall govern and supersede any contract terms to the contrary with respect to each procurement. Contractor shall verify to the West Virginia Regional Education Service Agencies (WVRESA), its Member Agencies and other qualifying purchasers that the Contractor is complying with all Federal, State and Local Laws, Codes and Regulations while fulfilling the contract, and shall provide a copy of this contract and any addenda to each Member Agency when providing a price quotation. Moreover, this contract shall be governed by and construed in accordance with the laws of the State of West Virginia without giving effect to its principles of conflict of law. Legal proceedings arising under this contract shall be brought in a West Virginia Court of the County where the Member Agency's main office is located.

ii. Delinquent Tax Affidavit

Contractor shall provide an affidavit relating to delinquent taxes as may be required by West Virginia State Code §11-12-10.

iii. Secretary of State Registration

Contractor shall meet and maintain all registration requirements as necessary to conduct business in the State of West Virginia, including but not limited to registration with the West Virginia Secretary of State.

iv. West Virginia Workers Compensation Insurance

Contractor, and any subcontractors hired by Contractor shall, at their own expense, maintain in force for the duration of the project workers' compensation and employer's liability insurance as required by the laws of the State of West Virginia.

v. Project Personnel, Student Safety and Background Checks

Member Agency shall have the right to reject the participation of any personnel of Contractor in the performance of the services if, in relation to the work assigned to them, the Member Agency deems such personnel to lack the skill, experience and expertise required to perform the services or if Member Agency considers their performance to be substandard or otherwise detrimental to the proper completion of the services. Contractor will advise Member Agency promptly of any change in the project manager or other key personnel assigned to the performance of the services.

Contractor acknowledges that the safety of the Member Agency's students, employees, officials and guests is of the utmost importance. Contractor will endeavor to ensure that its officers, employees, agents, representatives, and consultants will take no action that would jeopardize the safety of the Member Agency's students, employees, officials, or guests. The Member Agency reserves the right to require Contractor's officers, employees, agents, representatives and consultants to wear identification and stay in designated work areas at all times while on the Member Agency's property. The Member Agency shall have the right to effect the immediate removal of any person associated in any way with Contractor from Member Agency property for failure to wear identification, for being outside a designated work Contractor shall perform or cause to be performed by the West Virginia State Police and Federal Bureau of Investigation criminal background check of any personnel that will be performing the services within the proximity of minors. Contractor shall notify the Member Agency of any proposed employee who has been convicted, pled guilty or pled "no contest" to a criminal offense, and the Member Agency reserves the right to reject the proposed employee with a criminal background. No person shall be employed by Contractor who has been found guilty of any of the criminal offenses enumerated in West Virginia State Code without prior approval of the Member Agency.

vi. Independent Contractor

Contractor shall be an independent contractor and neither Contractor nor any of its subcontractors, nor the employees of any thereof, shall be deemed to be the servants, employees, or agents of Member Agency. Contractor shall be responsible for paying all costs related to its employees and managers performing the services. Contractor shall remain liable and responsible to Member Agency for all of its obligations under this contract, regardless of whether the services are performed by the Contractor or a subcontractor of any tier.

vii. Ownership of Instruments of Service

Drawings, data and other documents prepared by, or with the cooperation of, the Contractor pursuant to this contract shall become, upon payment of all undisputed compensation due the Contractor from the Member Agency, the property of the Member Agency. Such drawings, data or other documents may be used by the Member Agency or others employed by the Member Agency without compensation to the Contractor.

viii. Audit

Member Agency may audit and inspect Contractor's records and accounts at any time during the Contractor's performance of the services and for a period of two (2) years following the completion or termination of the services for the purpose of verifying any invoice and underlying documentation presented by Contractor, it being understood that Contractor agrees to preserve all such documents through such two- (2) year period.

ix. Notices

Unless otherwise expressly provided in this contract, all notices and other communications given under the contract shall be in writing and shall be deemed effective upon receipt by the addressee at its address as set forth in the contract or at such other address as such party shall have notified the other in writing.

x. Non-Appropriation and Other Contract Terms Applicable to Member Agencies as Political Subdivisions of the State

If the Member Agency fails to appropriate sufficient monies in any fiscal year for payments due under the contract and other funds are not available for such payments, then a "Non-Appropriation" shall be deemed to have occurred. If a Non-Appropriation occurs, then Member Agency will give Contractor prompt notice of such Non-Appropriation. This contract shall thereupon terminate without penalty or expense to the Member Agency other than for goods and services already provided.

xi. No Personal Liability

It is understood and agreed that under no circumstances will the Member Agency's board members, regional council members, officers, employees, or agents be personally liable for any obligations or claims arising out of or related to the contract.

xii. Price Quotation

Contractors must quote to a Member Agency the pricing listed in the current contract awarded by the Association of Educational Purchasing Agencies. Vendor will follow the procedures for price reductions to AEPA Member Agencies and Participating Entities set forth in the AEPA general terms area, and conditions. The price quotation must be submitted to a Member Agency and Participating Entity in writing, and any other expenses that the Contractors intend to charge a Member Agency or Participating Entity must be separately itemized on the quotation page in bold font with a good faith estimate of the dollar amount of each item, such as use tax if applicable. The failure to list an item or include a good faith estimate of the dollar amount on the quotation page will preclude a Contractor from charging the same.

xiii. Miscellaneous

Headings and titles of articles, paragraphs and other subparts of this contract are for convenience of reference only and shall not be considered in interpreting the text of this contract. This contract and any appendices constitute the entire agreement of the parties with respect to the subject matter hereof and supersedes all prior agreements or understandings with respect thereto and all agreements or understandings with a Member Agency. No contract amendments can be made without the approval of the AEPA membership.

B. Construction Products and Services:

For construction improvements, the following shall apply:

1. The successful Contractor shall provide such bonds required by West Virginia State Code §38- 2-39.
2. Contractor shall comply with all applicable licensing requirements, including those of the West Virginia Contractor Licensing Board pursuant to West Virginia State Code §21-11-3.

C. Procedures for Processing Orders:

The WVRESA will keep informed its Member Agencies and other qualified purchasers of contract information via web site and through other marketing strategies. A list of WVRESA Member Agencies along with addresses, phones, contacts, etc. will be made available to successful Contractors. After contracts are awarded, Contractors may contact the WVRESA Member Agencies and other qualifying purchasers concerning their products and services.

Participating Member Agencies and other qualified purchasers will submit all purchase orders directly to the Contractor.

The Contractor price shall include a two percent (2%) administrative fee that the Contractor will collect from the Member Agency or other qualified purchaser. Administrative fees are to be remitted to the WVRESA on April 15, July 15, October 15 and January 15 of every calendar year with checks payable to the RESA 2, 2001 McCoy Road, Huntington, WV 25701

The Contractor will compile a quarterly report showing all purchases made by the WVRESA Member Agencies and other qualified purchasers under this contract at the conclusion of each calendar quarter. These reports shall be attached to the administrative fee remittance.

D. Agencies Allowed to Purchase under Member Agency:

All member cooperatives of the WVRESA and their individual Member Agencies are eligible to participate and purchase from the awarded AEPA contracts. All West Virginia PK-12 school districts, including Career and Technical Education Centers, Regional Education Services Agencies, West Virginia Department of Education (WVDE) and all Institutional Education Programs operated by WVDE are eligible to participate and purchase from the awarded AEPA contracts. In addition, all colleges and universities, state, municipalities, counties, other governmental agencies and non-profit agencies are eligible to participate if the AEPA contracts satisfy their individual procurement requirements.

27. Wisconsin, Cooperative Educational Service Agency (CESA) Purchasing

A. Additional Terms and Conditions

(Note: anything that is not already in Part A – General Terms and Conditions for AEPA) Terms and Conditions must be compliant with Wisconsin State Statutes 16.70 to 16.848

B. *Additional Participating Agency Terms and Conditions for Non-Construction Products and Services* Some larger districts, like Milwaukee Public Schools, may require an additional one page “piggyback” memorandum of understanding to utilize the contract.

C. Additional Participating Agency Terms and Conditions for Construction Related Products and Services
Construction contracts are subject to Wisconsin State Statutes 16.855 or 66.0901.

D. Procedure for Processing Orders

All districts directly process orders with the CESA Purchasing AEPA vendor partner unless otherwise arranged.

E. Members Purchasing Under CESA

CESA Purchasing membership is free. Membership is available to the following agencies based on WI State Statutes Chapter 116 which governs the work of WI Cooperative Educational Service Agencies: school districts, University of Wisconsin System institutions, and technical colleges. All public, private, and tribal schools, and all public and private agencies and organizations, that provide services to pupils. Please note in Wisconsin we do not require additional registration of members and define members as those defined by WI Statute 116 that guides our work.

28. Wyoming, Northeast Wyoming Board of Cooperative Educational Services (NEW BOCES):

Upon execution of this document, the respondent hereby agrees to submit bids and NEW BOCES agrees to accept such bids under the following conditions:

PREFERENCES Wyoming Statutes provide for percentage preferences for items supplied by Wyoming resident bidders and for items produced or grown in the State of Wyoming. Preferences may not be applied when federal funds are involved. Preference will be given in accordance with W.S. 16-6-101, 16-6-102, 16-6-103, 16-6-104, 16-6-105, 16-6-106, 16-6-107, and 16-6-301, as amended. For bids involving federal funds please refer to W.S. 16-6-108. Please contact the Department of Workforce Services, Division of Labor Standards

Resident & Non-Resident VENDOR REGISTRATION REQUIREMENTS:

Secretary of State 2020 Carey Avenue Cheyenne, WY 82002 Phone: (307) 777-7378 website:

<http://soswy.state.wy.us/>

Department of Workforce Services Division of Unemployment Insurance 100 W. Midwest P.O. Box 2760 Casper, WY 82602 Phone: (307) 235-3217

Public Works and Contracts: Vendor shall comply with all laws, whether local, state, federal, or otherwise, applicable to any aspect of the service or product to be provided in relation to the contract. It shall be the vendor's responsibility to determine the applicability and requirements of any such laws and to abide by them. Vendor shall indemnify, defend, and hold harmless NEW BOCES for any default or breach of vendor in this regard. To the extent applicable for the product or service bid, vendor shall comply with W.S. 16-6-101 to 16-6-602 and to W.S. 21-3-110(a) (viii)

Every Contracted Vendor Employee shall provide a valid State issued Identification Card upon entry of any educational facility.

Members Customer Client Purchasing: NEW BOCES NEW BOCES is an educational cooperative authorized under the provisions of W.S. 21-20-101 to 21-20-111. All K-12 school districts, Community Colleges, Child Development Centers, Residential Child Care Institutions, Utah Educational Service Agencies, all Non-Profits and all Municipalities are eligible to participate in NEW BOCES cooperative purchasing programs within the State of Wyoming and Other States as requested. "Agencies" means Counties, Municipal Corporations, School Districts, Community College Districts, the joint business council of the Eastern Shoshone and Northern Arapaho Indian tribes, the business council of the Eastern Shoshone Indian tribe, the business council of the Northern Arapaho Indian tribe. Providing facilities or functions enumerated in W.S. 16-1-104(c); No member user is obligated to use these services, but they find the benefits of economy and efficiency made possible by cooperative purchasing to be advantageous.

Procedure for Processing Orders: Upon bid award to the Contractors/Vendors, NEW BOCES will inform its members and other qualifying purchasers of the contract:

- When the customer identifies a desired product or service as available through the AEPA/NEW BOCES contract and agrees on price as presented to the customer by the awarded AEPA/NEW BOCES vendor, the customer then issues to the vendor a purchase order for that item or service.
- The vendor's price shall include a two percent (2%) administrative/marketing fee on all sales of products and or services that the vendor will collect from the member or other qualifying purchaser. This fee will be remitted to NEW BOCES on a quarterly basis.
- Administrative/Marketing fees will be payable to NEW BOCES on the 15th in the months of April, July, October, and January with all checks payable to NEW BOCES, 410 North Miller Avenue, Gillette, Wyoming 82716.
- Vendor makes all deliveries and installation of products and services. NEW BOCES does not warehouse items nor provide services.
- No other Cooperative shall be offered or used by awarded Contracted Vendors within the participating member customer clients of NEW BOCES.

Vendor Contact: Vendor will designate to NEW BOCES an individual(s) who will represent them. This contact person(s) will correspond with each ordering member for technical assistance, problems, or questions that may arise. Include instructions if different contacts for different geographical areas are needed; this information will be distributed to NEW BOCES members upon award of this bid.

NEW BOCES Commitment to Awarded Contract Vendors:

- 1) Website postings www.newboces.com under Cooperative Purchasing. Includes but not limited to News & Announcements, Awarded Contracts, Flyers, and Online Ordering. Available catalogs from Vendors must be provided for customer online ordering.
- 2) Announcing the contract in its quarterly newsletter and other events completed with vendors which includes savings reports and rebates to members and users of NEW BOCES Cooperative Contracts.
- 3) Publish the Vendor information in a catalog disseminated to all members and marketing for new members.
- 4) Attend Annual Conferences for Trade Show product purposes of all contracts held by NEW BOCES.

Including any other suggestions or support from Vendors. A list of members and other qualifying purchasers, addresses, and phone numbers will be made available to the Contracted Vendor.



Part D - Questionnaire

AEPA IFB 020-E

Lawn & Groundskeeping Equipment, Supplies & Services

Instructions

This questionnaire contains forms and requests for information required by AEPA for vendor evaluation for responsiveness and responsibility.

To submit the required forms, follow these steps:

1. Read the documents in their entirety.
2. Bidders must use Part D – Questionnaire to its capacity. Attached exhibits and/or supplemental information should be included only when requested (i.e. Annual Report, Marketing Plan).
3. Complete all questions.
4. Save all pages in the correct order to a single PDF format titled “**Part D – Questionnaire – Name of Bidding Company**”.
5. Submit Part D, along with other required documents in Public Purchase.

The following sections will need to be completed prior to submission and submitted as one single PDF titled “Part D – Questionnaire – Name of Bidding Company”:

Company Information

Service Questionnaire

Exceptions

Deviations

Company Information

Name of Bidding Company: _____

Company Address: _____

City, State Zip code: _____

Website: _____

Contact Person: _____

Title: _____

Phone: _____

Email: _____

Background

Note: Generally, AEPA will not accept an offer from a business that is less than five (5) years old or, which fails to demonstrate and/or establish a proven record of business. If the bidder has recently purchased an established business or, has proof of prior success in either this business or a closely related business, provide written documentation and verification in response to the questions below. AEPA reserves the right to accept or reject newly formed companies based on information provided in this response and from its own investigation of the company.

This business is a: _____ public company _____ privately owned company

In what year was this business started under its present name? _____

Under what additional, or, former name(s) has your business operated? _____

Is this business a corporation? _____ No _____ Yes. If yes, complete the following:

Date of Incorporation: _____

State of Incorporation: _____

Name of President: _____

Name(s) of Vice President(s): _____

Name of Treasurer: _____

Name of Secretary: _____

Is this business a partnership? _____ No _____ Yes. If yes, complete the following:

Date of Partnership: _____

State Founded: _____

Type of Partnership, if applicable: _____

Name(s) of General Partner(s): _____

Is this business individually owned? _____ No _____ Yes. If yes, complete the following:

Date of Purchase: _____

State Founded: _____

Name of Owner/Operator: _____

Is this business different from those identified above? _____ No _____ Yes
 If yes, describe the company's format, year and state of origin and names and titles of the principles below.

Is this business women owned? _____ No _____ Yes

Is this business minority owned? _____ No _____ Yes

Does this business have an Affirmative Action Plan/Statement? _____ No _____ Yes

Business Headquarter Location

Business Address _____
City, State Zip code _____
Phone _____
How long at this address? _____

Business Branch Location(s)

Branch Address _____
City, State Zip code _____
Branch Address _____
City, State Zip code _____
Branch Address _____
City, State Zip code _____
Branch Address _____
City, State Zip code _____

**If more branch locations exist, insert information here or add another sheet with the above information.*

Sales History

Provide your business's annual sales for 2017, 2018, and 2019 YTD in the United States by the various public segments.

	2017	2018	2019 YTD
K-12 (public & private), Educational Service Agencies			
Higher Education Institutions			
Counties, Cities, Townships, Villages			
States			
Other Public Sector & Non-profits			
Private Sector			
Total			

Work Force

Key Contacts and Providers: Provide a list of the individuals, titles, and contact information for the individuals who will provide the following services on a national and/or local basis:

Function	Name	Title	Phone	Email
Contract Manager				
Sales Manager				
Customer & Support Manager				
Distributors, Dealers, Installers, Sales Reps				
Consultants & Trainers				

Technical, Maintenance & Support Services				
Quotes, Invoicing & Payments				
Warranty & After the Sale				
Financial Manager				

Sales Force: Provide total number and location of salespersons employed by your business in the United States by completing the following: *(To insert more rows, hit the tab key from the last field in the State column.)*

Number of Sales Reps	City	State

Service/Support and Distribution Centers: Provide the type (service/support or distribution) and location of centers that support the United States by completing the following: *(To insert more rows, hit the tab key from the last field in the State column.)*

Center Type	City	State

Marketing

Key Marketing Contact(s): List the name(s), title(s) and contact information of the business’s key national and regional marketing office(s). *(To insert more rows, hit the tab key from the last field in the Email column.)*

Name	Title	Phone	Email

Marketing Activities: Describe how this business marketed its products and services to schools, nonprofit organizations and other public sector audiences in Fiscal Year 2018– 2019 (July 1 – June 30). List all conventions, conferences and other events at which this company exhibited.

Click or tap here to enter text.

Cooperative Marketing: Describe ways in which this business can collaborate with AEPA Member Agencies in marketing the bid. Submit a marketing plan, titled Exhibit B – Marketing Plan, that would entail at a minimum, the following with their response: process on how the contract will be launched to current and potential agencies, the ability to produce and maintain in full color print advertisements in camera-ready electronic format, including company logos and contact information, anticipated contract announcements, planned advertisements, industry periodicals, other direct or indirect marketing activities promoting the AEPA awarded contract, and how the contract award will be displayed/linked on the Bidder’s website.

Click or tap here to enter text.

Sales Training: Explain how your business will educate your salesforce staff on the AEPA contract including timing, methods, etc.

Click or tap here to enter text.

Environmental Initiatives

Describe how your products and/or services support environmental goals.

Click or tap here to enter text.

Describe the business's "green" objectives (i.e. LEED, reducing footprint, etc.).

Click or tap here to enter text.

Independent Subcontractors, Distributors, Installers, etc.

If the Bidder is not the sole provider of all goods and services provided under this contract, the following **must be answered**:

Selection Criteria for Independent Providers: Describe the criteria and process by which the business selects, certifies and approves subcontractors, distributors, installers and other independent services.

Click or tap here to enter text.

Current Subcontractors, Distributors, Installers, etc.: Provide a list of current subcontractors, distributors, installers and other independent service providers who are contracted to perform the type of work outlined in this bid in the member agency states (listed in Part A of this IFB). Include, if applicable, contractor license or certificate information and the state(s) wherein they are eligible to provide services on behalf of the business.

Click or tap here to enter text.

Disclosures

Line of Credit Letter or Annual Financial Report (REQUIRED): Attach a letter from the business's chief financial institution indicating the current line of credit available to the business and evidence of financial stability for the past three calendar years (2016, 2017 and 2018). This letter should state the line of credit as a range (i.e. "credit in the low six figures" or "a credit line exceeding five figures"). If company is a publicly traded company a complete Annual Financial Report is required in place of Line of Credit Letter.

Alternatively, Bidders may choose to send the Letter of Line of Credit and/or Annual Report by email directly to the AEPA Executive Director, George Wilson, at georgewilson.aepa@outlook.com. The Letter of Line of Credit and/or Annual Report must be received by the Executive Director before the due date and time of the bid opening.

Legal: Does this business have actions currently filed against it? _____ No _____ Yes

If **Yes**, AN ATTACHMENT IS REQUIRED: List and explain current actions, such as, Federal Debarment (on US General Services Administration’s “Excluded Parties List”), appearance on any state or federal delinquent taxpayer list, or claims filed against the retainage and/or payment bond for projects.

References

Provide contact information of your business’s five largest public agency customers:

Agency	Name	Title	Phone Number	Email
1.				
2.				
3.				
4.				
5.				

Service Questionnaire

The following chart indicates which AEPA Member States intend to participate in this bid category. Respond to Yes/No and choice questions by using an (X). **Note: A Bidder must be willing and able to deliver the proposed products and/or services to 90% of the participating AEPA Member States, unless otherwise stated within Part B Technical Specifications. .**

AEPA Member States	Participating in this bid category?	Has the bidding company sold products/services in these states for the past three (3) years? (Yes or No)	If awarded, which states does the bidding company propose to sell in? (Place an X where applicable)	Indicate which states the bidding company has sales reps, distributors or dealers in. (Place an X where applicable)
California	Yes			
Colorado	Yes			
Connecticut	Yes			
Florida	Yes			
Georgia	Yes			
Illinois	No			
Indiana	Yes			
Iowa	Yes			
Kansas	Yes			
Kentucky	Yes			
Massachusetts	Yes			
Michigan	Yes			
Minnesota	Yes			
Missouri	Yes			
Montana	Yes			
Nebraska	Yes			
New Jersey	Yes			
New Mexico	Yes			
North Dakota	Yes			
Ohio	Yes			
Oregon	Yes			
Pennsylvania	Yes			
Texas	Yes			
Virginia	Yes			
Washington	Yes			
West Virginia	Yes			
Wisconsin	Yes			
Wyoming	Yes			

e-Commerce: Does this business have an e-commerce website? _____ **No** _____ **Yes**
 If YES, what is the website? _____

Customer and Support Service: It is understood depending on the type, kind and level of products and/or services being proposed in response to this bid will impact and determine the type and level of services required and these are identified in Part B Bid Specifications of this IFB.

Does this business have online customer support options? _____ **No** _____ **Yes**

Does this business have a toll-free customers support phone option? _____ **No** _____ **Yes**

Does this business offer local customer and support service options? _____ **No** _____ **Yes**

Training: If applicable, does this business offer customer training for the products and services sold? _____ **No** _____ **Yes**

If YES, describe what types/kinds of training you offer, the venues where training occurs and the location(s) of your trainers, include number of staff dedicated to training and their qualifications and hours of operation.
Click or tap here to enter text.

Pricing:

Is your pricing methodology guaranteed for the term of the contract? _____ **No** _____ **Yes**

Will you offer customized price lists to participating entities as required per the pricing terms of Part A? _____ **No** _____ **Yes**

Will you offer hot list pricing (optional) as described in the pricing terms of Part A? _____ **No** _____ **Yes**

Will you offer volume price discounts as described in the pricing terms of Part A? _____ **No** _____ **Yes**

Competitiveness: In order for your bid to be considered, your company must offer AEPA prices that are equal to or lower than those normally offered to individual entities or cooperatives with equal or lower volume.

Is the pricing that is proposed to AEPA equal to or lower than pricing your company offers to individual entities or cooperatives with equal to or lower volume? _____ **No** _____ **Yes**

Indicate which of the following apply and the **level of competitive range** you are offering in response to this IFB.

- _____ Pricing offered to AEPA is EQUAL TO pricing offered to individual customer and/or cooperatives.
- _____ Pricing is LESS THAN individual customer and/or cooperatives. Lower by _____%

Cooperative Contracts: Does your business currently have contracts with other cooperatives (local, regional, state, national)? _____ **No** _____ **Yes**

If YES, identify which cooperative and the respective expiration date(s).
Click or tap here to enter text.

If YES, and your business is awarded an AEPA contract, explain which contract your business will lead with in marketing and sales representative presentations (sales calls)?
Click or tap here to enter text.

Administrative Fee: Which of the following best reflects how your pricing includes the individual AEPA Members' administrative fee. Mark with an "X".	
<input type="checkbox"/>	The pricing for the products and/or services are the same for each AEPA Member Agency, shipping, handling, administrative fee and other specific state costs are added to arrive at total price offered to the Individual AEPA Member Agency.
<input type="checkbox"/>	The pricing for the products and/or services is inclusive of the administrative fee and therefore the pricing is the same for all AEPA Member Agencies. Shipping, handling and other state specific costs are added to the adjusted AEPA Member Agency's price.
<input type="checkbox"/>	The pricing for the products and/or services includes ALL (shipping, handling, administrative fee, other) costs to arrive at a single price for all AEPA Member Agencies.

Shipping & Handling: Orders that are \$50.00 or more shall include shipping and handling. What is the flat rate your company will charge, regardless of where shipped in the continental United States, for orders less than \$50.00?	\$
---	----

Product Returns: Does your business have a return policy? **No** **Yes**

If YES, describe your return policy and if you charge a restocking fee, what is it? (AEPA allows up to 15% for supplies and up to 25% for equipment).

Click or tap here to enter text.

Payment Terms: Will your business offer AEPA buyer's a quick pay discount?

No **Yes**

If YES, what is the discount? %Net

Leasing: Does your business offer leasing arrangements under this bid?

No **Yes**

If Yes, please indicate the rate factor and other cost factors below.

If an AEPA contract is approved and awarded by the Member Agencies, as a Vendor Partner, I agree to:

Responsibilities of an AEPA Vendor Partner	Yes, indicate with an "X"	No, indicate with an "X"
1. Designate and assign a dedicated senior-level contract manager (one authorized to make decisions) to each of the Member Agency accounts. This employee will have a complete copy and must have working knowledge of the AEPA contract.		
2. Train and educate sales staff on what the AEPA contract is: including pricing, who can order from the contract (by state), terms/conditions of the contract, and the respective ordering procedures for each state. It is expected that Vendor Partners will lead with AEPA contracts.		
3. Develop a marketing plan to support the AEPA contract in collaboration with respective AEPA Member Agencies. The marketing plan should include, but not be limited to, a website presence, electronic mailings, sales flyers, brochures, mailings, catalogs, etc.		
4. Create an AEPA-specific sell sheet with a space to add a Member Agency logo and contact information for use by the Member Agencies and the Vendor Partner's local sales representatives to market within each state.		

5. On a quarterly basis, complete the sales and administrative fee report (see attached PDF example) and submit to each Member Agency along with the respective administrative fees to be paid. If there are no sales, the Vendor Partner is required to submit a \$0 report to the AEPA Member Agency.		
6. Have ongoing communication with the Bid Oversight Chairperson, AEPA Member Agencies and the Member Agencies Participating Entities.		
7. Attend two (2) AEPA meetings each year (see Part A)		
8. Participate in national and local conference trade shows to promote the AEPA contracts including, but not limited to the Association of School Business Officials (ASBO), the National Institute of Governmental Purchasing (NIGP), and the National Association of Educational Procurement (NAEP).		
9. Increase sales over the term of the contract with all participating AEPA Member Agencies.		

Deviations

Definition: Deviations can be defined as a major variance, change, or substitution submitted by a Bidder, which deviates from, adds extraneous terms to, conflicts with or offers an alternative to any term, condition, specification or requirement of this solicitation.

Instructions:

1. If “no” is marked with an “X” below, complete this form by signing it at the bottom.
2. If “yes” is marked with an “X” below, insert answers into the form shown below, providing narrative explanations of deviations. *(To insert more rows, hit the tab key from the last field in the last row and column.)*
3. If adding pages, the bidder’s name and identifying information as to which item the response refers must appear on each page.
4. Deviations to local, state or federal laws cannot be accepted under this bid.

	No , this bidder does not have deviations (exceptions or alternates) to the specifications listed in Part B of this IFB.
	Yes , this bidder has the following deviations to the specifications listed in Part B of this IFB.

Outline Number Part B	Specification (describe)	Details of Deviation



Part E – Signature Forms

AEPA IFB 020-E

Lawn & Groundskeeping Equipment, Supplies & Services

Instructions

Contained herein are forms that require a signature from an authorized person at your company. All items found within this document are **mandatory**. Failure to sign the required areas, sections, or signature lines will allow AEPA to consider your company's proposal as **non-responsive**.

To submit the required signed forms, follow these steps:

1. Read the documents in their entirety.
2. Complete all forms and sign when required.
3. Once signed, place notary stamp in the delegated area on the Bid Affidavit.
4. Return the forms and pages in their correct order and scan one (1) single PDF format titled "Part E - Signature Forms - Name of Bidding Company" (i.e. one PDF document for all signature forms).
5. Submit Part E, along with other required documents in Public Purchase.

AEPA does not allow electronic signatures.

*Note, a bid checklist has been provided to review with your submission.

The following sections will need to be completed prior to submission as one (1), single PDF titled "Part E - Signature Forms - Name of Bidding Company".

Uniform Guidance "EDGAR" Certification Form – **signature required*

Bid Affidavit – **signature required*

Acceptance of Bid & Contract Award – **signature required*

Uniform Guidance “EDGAR” Certification Form

2 CFR Part 200

When a purchasing agency seeks to procure goods and services using funds under a federal grant or contract, specific federal laws, regulations, and requirements may apply in addition to those under state law. This includes, but is not limited to, the procurement standards of the Uniform Administrative Requirements, Cost Principles and Audit Requirements for Federal Awards, 2 CFR 200, referred to as the “Uniform Guidance” or new “EDGAR”. All bidders submitting proposals must complete this EDGAR Certification form regarding the bidder’s willingness and ability to comply with certain requirements, which may be applicable to specific agency purchases using federal grant funds.

For each of the items below, the Bidder will certify its agreement and ability to comply, where applicable, by having the bidder’s authorized representative check, initial the applicable boxes, and sign the acknowledgement at the end of this form. If a bidder fails to complete any item of this form, AEPA will consider and may list the response, as the bidders is unable to comply. A “No” response to any of the items below may influence the ability of a purchasing agency to purchase from the bidder using federal funds.

1. Violation of Contract Terms and Conditions

Provisions regarding bidder default are included in AEPA’s terms and conditions. Any contract award will be subject to such terms and conditions, as well as any additional terms and conditions in any purchase order, ancillary agency contract, or construction contract agreed upon by the bidder and the purchasing agency, which must be consistent with and protect the purchasing agency at least to the same extent as AEPA’s terms and conditions. The remedies under the contract are in addition to any other remedies that may be available under law or in equity.

2. Termination for Cause of Convenience

For a participating agency purchase or contract in excess of \$10,000 made using federal funds, you agree that the following term and condition shall apply:

The participating agency may terminate or cancel any purchase order under this contract at any time, with or without cause, by providing seven (7) business days in advance written notice to the bidder. If this agreement is terminated in accordance with this paragraph, the participating agency shall only be required to pay bidder for goods and services delivered to the participating agency prior to the termination and not otherwise returned in accordance with the bidder’s return policy. If the participating agency has paid the bidder for goods and services provided as the date of termination, bidder shall immediately refund such payment(s).

If an alternate provision for termination of a participating agency’s purchase for cause and convenience, including the manner by which it will be effected and the basis for settlement, is in the participating agency’s purchase order, ancillary agreement or construction contract agreed to by the bidder, the participating agency’s provision shall control.

3. Equal Employment Opportunity

Except as otherwise provided under 41 CFR Part 60, all participating agency purchases or contract that meet the definition of “federally assisted construction contract” in 41 CFR Part 60-1.3 shall be deemed to include the equal opportunity clause provided under 41 CFR 60-1.4(b), in accordance with Executive Order 11246, “Equal Employment Opportunity” (30 FR 12319, 12935, 3 CFR Part, 1964-1965 Comp., p. 339), as amended by Executive Order 11375, “Amending Executive Order 11246 Relating to Equal Employment Opportunity,” and implementing regulations at 41 CFR Part 60, “Office of Federal Contract Compliance Programs, Equal Employment Opportunity, Department of Labor.”

The equal opportunity clause provided under 41 CFR 60-1.4(b) is hereby incorporated by reference. Bidder agrees that such provision applies to any participating agency purchase or contract that meets the definition of “federally assisted construction contract” in 41 CFR Part 60-1.3 and bidder agrees that it shall comply with such provision.

4. Davis Bacon Act

When required by Federal program legislation, bidder agrees that, for all participating agency contracts for the construction, alteration, or repair (including painting and decorating) of public buildings or public works, in excess of \$2,000, bidder shall comply with the Davis-Bacon Act (40 U.S.C. 3141-3144, and 3146-3148) as supplemented by Department of Labor regulations (29 CFR Part 5, "Labor Standards Provisions Applicable to Contracts Covering Federally Financed and Assisted Construction"). In accordance with the statute, bidder is required to pay wages to laborers and mechanics at a rate not less than the prevailing wages specific in a wage determinate made by the Secretary of Labor. In addition, bidder shall pay wages not less than once a week.

Current prevailing wage determinations issued by the Department of Labor are available at www.wdol.gov. Bidder agrees that, for any purchase to which this requirement applies, the award of the purchase to the bidder is conditioned upon bidder's acceptance of wage determination.

Bidder further agrees that is shall also comply with the Copeland "Anti-Kickback" Act (40 U.S.C. 3145), as supplemented by Department of Labor regulations (29 CFR Part 3, "Contractors and Subcontractors on Public Building or Public Work Financed in Whole or in Part by Loans or Grants from the United States"). The Act provides that each construction completion, or repair of public work, to give up any part of the compensation to which he is otherwise entitled under his contract of employment, shall be defined under this titled or imprisoned not more than five (5) years, or both.

5. Contract Work Hours and Safety Standards Act

Where applicable, for all participating agency purchases in excess of \$100,000 that involve the employment of mechanics or laborers, bidder agrees to comply with 40 U.S.C. 3702 and 3704, as supplemented by Department of Labor regulations (29 CFR Part 5). Under 40 U.S.C. 3702 of the Act, bidder is required to compute the wages of every mechanic and laborer on the basis of a standard work week of 40 hours. Work in excess of the standard work week is permissible provided that the worker is compensated at a rate of not less than one and a half times the basic rate of pay for all hours worked in excess of 40 hours in the work week. The requirements of the 40 U.S.C. 3704 are applicable to construction work and provide that no laborer or mechanic must be required to work in surroundings or under working conditions that are unsanitary, hazardous or dangerous. These requirements do not apply to the purchase of supplies, materials or articles ordinarily available on the open market, or contracts for transportation or transmission of intelligence.

6. Right to Inventions Made Under a Contract or Agreement

If the participating agency's federal award meets the definition of "funding agreement" under 37 CFR 401.2(a) and the recipient or sub recipient wishes to enter into a contract with a small business firm or nonprofit organization regarding the substitution of parties, assignment or performance or experiments, developmental or research work under the "funding agreement," the recipient or sub recipient must comply with the requirements of 37 CFR Part 401, "Rights to Inventions Made by Nonprofit Organizations and Small Business Firms Under Government Grants, Contracts and Cooperative Agreements," and any implementing regulations issued by the awarding agency.

7. Clean Air Act and Federal Water Pollution Control Act

Clean Air Act (42 U.S.C. 7401-7671q.) and the Federal Water Pollution Control Act (33 U.S.C. 1251-1387), as amended, contracts and sub grants of amounts in excess of \$150,000 must contain a provision that requires the non-Federal award to agree to comply with all applicable standards, orders, or regulations issued pursuant to the Clean Air Act (42 U.S.C. 7401-7671q.) and the Federal Water Pollution Control Act, as amended (33 U.S.C. 1251-1387). Violations must be reported to the Federal awarding agency and the Regional Office of the Environmental Protection Agency (EPA). When required, bidder agrees to comply with all applicable standards, orders, or regulations issued pursuant to the Clean Air Act and the Federal Water Pollution Control Act.

8. Debarment and Suspension

Debarment and Suspension (Executive Orders 12549 and 12689), a contract award (see 2 CFR 180.222) must not be made to parties listed on the government-wide exclusions in the System for Award Management (SAM), in accordance with OMB guidelines at 2 CFR 180 that implement Executive Orders 12549 (3 CFR Part 1966 Comp. p. 189) and 12689 (3 CFR Part 1989 Comp. p. 235), "Debarment and Suspension." SAM exclusions contain the names of parties debarred, suspended, or otherwise excluded by agencies, as well as parties declared ineligible under statutory or regulatory authority other than Executive Order 12549. Bidder certifies that the bidder is not current listed and further agrees to immediately notify AEPA and all participating agencies with pending purchases or seeking to purchase from the bidder if bidder is later listed on the government-wide exclusions in SAM, or is debarred, suspended, or otherwise excluded by agencies or declared ineligible under statutory or regulatory authority other than Executive Order 12549.

9. Byrd Anti-Lobbying Amendment

Byrd Anti-Lobbying Amendment (31 U.S.C. 1352), bidders that apply or bid for an award exceeding \$100,000 must file the required certification. Each tier certifies to the tier above that it will not and has not used Federal appropriated funds to pay any person or organization for influencing or attempting to influence an officer or employee of any agency, a member of Congress, officer or employee of Congress, or an employee of a member of Congress in connection with obtaining any Federal contract, grant or any other award covered by 31 U.S.C. 1352. Each tier must also disclose any lobbying with non-Federal funds that take place in connection with obtaining any Federal award. Such disclosures are forwarded from tier to tier up to the non-Federal award.

10. Procurement of Recovered Materials

For participating agency purchases utilizing Federal funds, bidder agrees to comply with Section 6002 of the Solid Waste Disposal Act, as amended by the Resource Conservation and Recovery Act where applicable and provide such information and certifications as a participating agency may require to confirm estimates and otherwise comply. The requirements of Section 6002 include procuring only items designated in guidelines of the Environmental Protection Agency (EPA) at 40 CFR Part 247 that contain the highest percentage of recovered materials practicable, consistent with maintaining a satisfactory level of competition, where the purchase price of the item exceeds \$10,000 or the value of the quantity acquired during the preceding fiscal year exceeded \$10,000; procuring solid waste management services in a manner that maximizes energy and resource recover, and establishing an affirmative procurement program for procurement of recovered materials identified in the EPA guidelines.

11. Profit as a Separate Element of Price

For purchases using federal funds in excess of \$150,000, a participating agency may be required to negotiate profit as a separate element of the price. See 2 CFR 200.323(b). When required by a participating agency, bidder agrees to provide information and negotiate with the participating agency regarding profit as a separate element of the price for a particular purchase. However, bidder agrees that the total price, including profit, charged by the bidder to the participating agency shall not exceed the awarded pricing, including any applicable discount, under the bidders contract with AEPA.

12. General Compliance with Participating Agencies

In addition to the foregoing specific requirements, bidder agrees, in accepting any purchase order from a participating agency, it shall make a good faith effort to work with participating agency to provide such information and to satisfy requirements as may apply to a particular purchase or purchases including, but not limited to, applicable record keeping and record retention requirements as noted in the Federal Acquisition Regulation, FAR 4.703(a).

By initialing the table (1-12) and signing below, I certify that the information in this form is true, complete and accurate and that I am authorized by my business to make this certification and all consents and agreements contained herein.

Bidder Certification (By Item)	<u>Bidder Certification:</u> YES, I agree or NO, I do NOT agree	Initial
1. Violation of Contract Terms and Conditions		
2. Termination for Cause of Convenience		
3. Equal Employment Opportunity		
4. Davis-Bacon Act		
5. Contract Work Hours and Safety Standards Act		
6. Right to Inventions Made Under a Contract or Agreement		
7. Clean Air Act and Federal Water Pollution Control Act		
8. Debarment and Suspension		
9. Byrd Anti-Lobbying Amendment		
10. Procurement of Recovered Materials		
11. Profit as a Separate Element of Price		
12. General Compliance with Participating Agencies		

Name of Business

Signature of Authorized Representative

Printed Name

Date

Bid Affidavit

Instructions: This form must be signed by the business's authorized representative and notarized below. If awarded, the Bidder is required to produce a copy of this document for each Member Agency with which it contracts.

1. The undersigned, is duly authorized to represent the persons, business and corporations joining and participating in the submission of the foregoing bid (such persons, business and corporations hereinafter being referred to as the bidder), being duly sworn, on his/her oath, states that to the best of his/her belief and knowledge no person, business or corporation, nor any person duly representing the same joining and participating in the submission of the foregoing bid, has directly or indirectly entered into any agreement or arrangement with any other bidders, or with any official of the **Member Agency**, or any employee thereof, or any person, business or corporation under contract with the **Member Agency** whereby the bidder, in order to induce the acceptance of the foregoing bid by the **Member Agency**, has paid, or is to pay to any other bidder, or to any of the aforementioned persons, anything of value whatever, and that the bidder has not, directly nor indirectly entered into any arrangement, or agreement, with any other bidder or bidders which tends to or does lessen or destroy free competition in the letting of the contract sought for by the foregoing bid.
2. This is to certify that the bidder, or any person on his/her behalf, has not agreed, connived, or colluded to produce a deceptive show of competition in the manner of the bidding, or award of the referenced contract.
3. This is to certify that neither I, nor to the best of my knowledge, information and belief, the bidder, nor any officer, director, partner, member or associate of the bidder, nor any of its employees directly involved in obtaining contracts with the **Member Agency**, or any subdivision of the state has been convicted of false pretenses, attempted false pretenses, or conspiracy to commit false pretenses, bribery, attempted bribery or conspiracy to bribe under the laws of any state or federal government for acts or omissions after January 1, 1985.
4. This is to certify that the bidder, or any person on his behalf has examined and understands the terms, conditions, scope of work and specifications, and other documents of this solicitation and that any and all exceptions have been noted in writing and have been included with the bid submittal.
5. This is to certify that if awarded a contract, the bidder will provide the equipment, commodities, and/or services to members and affiliate members of the Agency in accordance with the terms, conditions, scope of work and specifications and other documents of this solicitation in the following pages of this bid.
6. This is to certify that the bidder is authorized by the manufacturer(s) to sell all proposed products on a national basis.
7. This is to certify that we have completed, reviewed, approved and have included all information that is required of these bid forms.

Authorized Representative (Please print or type)

Mailing Address

Title (Please print or type)

City, State, Zip

Signature of Authorized Representative

Date

Subscribed and sworn to before me this _____ day of _____

Notary Public in and for County of _____ State of _____

My commission expires on _____ Signature _____



Enter Notary Stamp



Acceptance of Bid & Contract Award

Instructions: PART I of this form is to be completed by the Bidder and signed by its Authorized Representative. PART II will be completed by the AEPA Member Agency only upon the occasion of the bid award. If approved by AEPA, the Bidder is required to produce a copy of the document for each of the AEPA Member Agency with which it contracts.

PART I: BIDDER

In compliance with the Invitation for Bid (IFB), the undersigned warrants that I/we have examined all Instructions to Bidders, associated documents, and being familiar with all of the conditions of the bid, hereby offer and agree to furnish all labor, materials, supplies and equipment incurred in compliance with all terms, conditions, specifications and amendments associated with this IFB and any written exceptions to the bid. Signature also certifies understanding and compliance with the certification requirements of the AEPA Member Agency's Terms and Conditions and/or Special Terms and Conditions. The undersigned understands that their competence, ability, capacity and obligations to offer and provide the proposed tangible personal property, professional services, construction services and other services on behalf of the Bidder Partner as well as other factors of interest to the AEPA Member Agency as stated in the evaluation section, will be a consideration in making the award.

Business Name	_____	Date	_____
Address	_____	City, State Zip	_____
Contact Person	_____	Title	_____
Authorized Signature	_____	Title	_____
Email	_____	Phone	_____

PART II: AWARDING MEMBER AGENCY

Your bid response for the above identified bid is hereby accepted. As a Bidder Partner you are now bound to offer and provide the products and services identified within this IFB, your response and approved by AEPA, including all terms, conditions, specifications, exceptions and amendments. As Bidder Partner, you are hereby not to commence any billable work or provide any products or services under this contract until an executed purchase order is received from the AEPA Member Agency or Participating Entities. The intent of this contract is to constitute the final and complete agreement between the AEPA Member Agency and Bidder Partner, and no other agreements, oral or otherwise, regarding the subject matter of this contract, shall bind any of the parties hereto. No change or modification of this contract shall be valid unless in writing and signed by both parties to this contract. If any provision of this contract is deemed invalid or illegal by any appropriate court of law, the remainder of this contract shall not be affected thereby. The initial term of this contract shall be for up to fifteen (15) months and will commence on the date indicated below and continue until February 28, 2021, unless terminated, canceled or extended. By mutual written agreement as warranted, the contract may be extended month by month up to six (6) months or for three (3) additional 12-month periods.

Awarding Agency _____

Authorized Representative _____

Awarded this	day of	Contract Number
Contract to commence		
(Member Agency to select)		Or March 1, 2020

Bid Checklist

Instructions: Utilize the checklist below, reviewing to confirm that all the required documents have been uploaded to Public Purchase, in their **specified/required format**, by the due date and time listed for this IFB. Bid **submissions not following the specified/required format may result as being marked non-responsive and may not be considered for evaluation.** Bidders are reminded that failure to follow, comply with, and adhere to the enclosed instructions of this solicitation may result in their response being deemed non-responsive. AEPA, its Member Agencies, affiliate agencies and authorized representatives are not responsible for bid proposals that are incomplete, unreadable, or received after the IFB deadline submission date.

"X"	Document Title, Uploaded to Public Purchase (Bidder must submit documents in the required title/format)	Format of Uploaded Document	Notes
	Bid Bond – if Required, see Part B if applicable.	Upload PDF copy. The original <u>must be</u> received by Oakland Public Schools by due date and time.	Send to Oakland Public Schools.
	Part C – State Specific Forms – Name of Bidding Company	Single, Scanned PDF	Required. Signatures Required.
	Part D - Questionnaire – Name of Bidding Company Includes: <ul style="list-style-type: none"> • Company Information • Service Questionnaire • Exceptions • Deviations 	Single, Scanned PDF	Required.
	Part E – Signature Forms – Name of Bidding Company Includes: <ul style="list-style-type: none"> • Uniform Guidance “EDGAR” Certification • Bid Affidavit • Acceptance of Bid & Contract Award 	Single, Scanned PDF	Required. Signatures required.
	Part F – Pricing Schedule – Name of Bidding Company	Excel Workbook	Required.
	Exhibit A – Annual Report/Letter of Credit – Name of Bidding Company	Scanned PDF	Required. Not provided by AEPA, Bidder Created
	Exhibit B – Marketing Plan – Name of Bidding Company	Scanned PDF	Optional. Not provided by AEPA, Bidder Created
	Exhibit C – Warranties, Additional Services – Name of Bidding Company	Scanned PDF	Optional. Not provided by AEPA, Bidder Created
	Exhibit D – Additional Discounts – Name of Bidding Company	Scanned PDF	Optional. Not provided by AEPA, Bidder Created



Part F.1 – Catalog Discount for Items in a Commercially Available Catalog

AEPA #020-E Lawn & Groundskeeping Equipment

Bidding Company Name:

Name of Catalog:
(This must be the catalog in effect as of the bid date)

Note: Groupings to be defined by Bidder and can be by sub-category, manufacturer, etc.

Enter company name here

Enter catalog name here

Part F.1 is a REQUIRED FORM

No.	Grouping of Discount	Discount Offered for This Grouping	Comments
1			
2			
3			
4			
5			
6			
7			
8			
9			
10			
11			
12			
13			
14			
15			
16			
17			
18			
19			
20			
21			
22			
23			
24			
25			
26			
27			
28			
29			
30			
31			
32			
33			
34			
35			
36			
37			
38			
39			
40			

If more categories are needed, add a new tab with similar formatting.



**Part F.2A – Core List Price Schedule
AEPA #020-E Lawn & Groundskeeping Equipment**

INSTRUCTIONS: Complete the following information for **all** core items listed below. These are higher usage items and it is anticipated that deeper discounts will be bid for these items. In the event a new catalog or manufacturer's price list changes during the contract term, the Bid Discount Percentage would not exceed the bid discount percentage.
Please be sure to set the 'Print Area' PRIOR to submitting your bid response.

NOTE: The Net Effective Price MUST be consistent with the percentage discounts listed on the F.1 tab. Failure to have price correspond may be cause for rejection of your offer.

Part F.2A is a REQUIRED FORM

Bidding Company Name:		Enter company name here				Enter catalog name here					
No.	Product Category	Product Description	Manufacturer	Manufacturer SKU	Vendor SKU	Unit of Measure	Catalog List Price	Bid Discount Percentage	Net Effective Bid Price	Comments	No.
1	Turf Vehicles & Attachments	Utility Vehicle/Tractor: A gas or diesel-powered all-purpose conveyance, capable of accepting multiple types of attachments for turf management and landscaping tasks. Uses drop-bar, pivot-pin, or three-point hitches for attachments. Engine strength of approximately 60 hp. Fuel capacity of approximately 15 gallons. Forward ground speed of approximately 20 mph. Includes hydraulics and lift capacity for approximately 2,200 pounds. Configured as base-vehicle, stock without any options. An example of a machine meeting these specifications would be the Toro Outcross 960 Turf Utility Vehicle or equivalent.				Each			\$ -		1
2	Turf Vehicles & Attachments	Light Utility Vehicle: A gas-powered grounds and turf crossover vehicle, capable of accepting attachments and multiple types of configurations, such as cabs, beds, seat extensions, lifts, and racks. Powered by an engine, sized approximately at 430cc with a fuel tank of approximately five gallons. Forward ground speed of approximately 16 mph. Towing capacity of approximately 1,500 pounds. Hydraulic disk brakes. Provide pricing for a vehicle configured with four-person bench seating, windshield, and four-foot flat bed, no canopy. An example of a machine meeting these specifications would be the Toro Gas-Powered Workman GTX or equivalent.				Each			\$ -		2
3	Turf Vehicles & Attachments	Reel Mower Gang Attachment with Seven Blades: Mowing width of approximately 14 feet. Variable height adjustments. Capable of mowing approximately 10.5 acres per hour for semi-formal cuts. An example of a machine meeting these specifications would be the Toro Reelmaster Model 01007, configured as 16" diameter w/ Semi-pneumatic Wheels, Model 01304 or equivalent.				Each			\$ -		3

Bidding Company Name:		Enter company name here				Enter catalog name here					
No.	Product Category	Product Description	Manufacturer	Manufacturer SKU	Vendor SKU	Unit of Measure	Catalog List Price	Bid Discount Percentage	Net Effective Bid Price	Comments	No.
4	Turf Vehicles & Attachments	Pull-Behind, Leaf and Debris Blower. Powered by an air-cooled engine with approximately 25 hp. Multi-directional blower chute. Axial flow, turbine-type fan assembly with blades approximately 14-inches wide. Category One, lawn-tractor style hitch. An example of a machine meeting these specifications would be the Toro CPro Force Series Debris Blower Model 4455Z or equivalent.				Each			\$ -		4
5	Wide-Area Mowers	Large Area, Sit-On Reel Mower: Minimum Cut Swath of Seven Feet Wide: Suitable for sports fields and golf greens. Constructed with steel, steel tube framing, and/or welded steel. Powered by a diesel engine of approximately 21 hp with a fuel tank of approximately seven gallons. Forward mow speed of approximately six mph. Hydraulic reel drive. Accepts attachments. An example of a machine meeting these specifications would be the Toro Reelmaster 2000-D or equivalent.				Each			\$ -		5
6	Wide-Area Mowers	Large Area, Sit-On Rotary Mower, Minimum Cut Swath of 11 Feet Wide: Suitable for rougher cut on fields, playgrounds, and greenscapes. Deck constructed with welded steel. Powered by a diesel engine of approximately 55 hp with a fuel tank of approximately 20 gallons. Forward mow speed of approximately eight mph. Multiple blades and decks. Four-wheel drive. Safe for hills. Open air seating; no cab. An example of a machine meeting these specifications would be the Toro Groundmaster Model 4000-D or equivalent.				Each			\$ -		6
7	Walk-Behind Mowers	Walk-Behind, Floating Deck, Cut Swath between 50 and 55 inches: Cutting swath between 50 and 55 inches. Twin lever steering controls. Two to three rotary blades. Steel deck construction. Powered by a gas engine of approximately 18 hp with a fuel tank of approximately five gallons. Forward groundspeed of approximately six mph. An example of a machine meeting these specifications would be the 52-inch Toro Floating Deck Hydro Drive Twin-Lever Model 30489 or equivalent.				Each			\$ -		7

Bidding Company Name:		Enter company name here				Enter catalog name here					
No.	Product Category	Product Description	Manufacturer	Manufacturer SKU	Vendor SKU	Unit of Measure	Catalog List Price	Bid Discount Percentage	Net Effective Bid Price	Comments	No.
8	Walk-Behind Mowers	<p>Walk-Behind, Fixed Deck, T-Bar Steering, Cut Swath between 48 and 52-Inches: Cutting swath between 48 to 52 inches. Preferred T-bar steering controls. Three rotary blades. Steel deck construction. Powered by a gas engine of approximately 14 hp with fuel tank of approximately five gallons. Forward groundspeed of approximately six mph. An example of a machine meeting these specifications would be the 48-inch Toro Fixed Deck Gear Drive T-Bar Model 39678 or equivalent.</p> <p>35 inches, California Compliant: Cutting swath of approximately 35 inches. Two rotary blades. Pistol grip steering. Recoil starter. Powered by a gas engine of approximately 14 hp with a fuel tank of approximately five gallons. Forward groundspeed of approximately six mph. Compliant with California Air Resource Board emission requirements. An example of a machine meeting these specifications would be the Toro Fixed Deck Hydro Drive Pistol Grip Model 39934 or equivalent.</p>				Each			\$ -		8
9	Walk-Behind Mowers	<p>Stand-On, Low Gravity, EFI, Cut Swath of 60 Inches: Low enter of gravity making machine suitable and safe on hills and slopes. Cutting swath of approximately 60 inches. Zero-turn capability. Rotary blades. Steel or welded-steel deck construction. Twin-lever steering. Powered by a fuel-injection, gas engine of approximately 25 hp with fuel tank of approximately 10 gallons. Forward groundspeed of approximately 10 mph. An example of a machine meeting these specifications would be the Toro GrandStand 60" EFI Model 74513 or equivalent.</p>				Each			\$ -		10
11	Stand-On Mowers	<p>Economy, Stand-On, Narrow Cut Swath of 36 Inches, California Compliant: Cutting swath of approximately 36 inches. Rotary blades. Steel deck construction. Twin-lever steering controls. Powered by a gas engine of approximately 15 hp with fuel tank of approximately eight gallons. Forward groundspeed of approximately eight mph. Compliant with California Air Resources Board emission requirements. An example of a machine meeting these specifications would be the Toro GrandStand 36" Model 74534 CARB or equivalent.</p>				Each			\$ -		11

Bidding Company Name:		Enter company name here				Enter catalog name here					
No.	Product Category	Product Description	Manufacturer	Manufacturer SKU	Vendor SKU	Unit of Measure	Catalog List Price	Bid Discount Percentage	Net Effective Bid Price	Comments	No.
12	Zero-Turn Mowers	Zero-Turn, Sit-On, Cut Swath of 48 to 50 inches; Heavy Duty Deck: Cutting swath of approximately 48 to 50 inches. Rotary blades. Extra heavy-duty steel deck construction, such as 10-gauge steel. Pro-controlled damper steering controls. Powered by a gas engine of approximately 22 hp with fuel tank of approximately five gallons. Forward groundspeed of approximately eight mph. An example of a machine meeting these specifications would be the Toro TimeCutter HD Zero Turn Mower Model 75201 or equivalent.				Each			\$ -		12
13	Zero-Turn Mowers	Zero-Turn, Sit-On, Cut Swath of 60-inches: Cutting swath of 60 inches or more. Rotary blades. Steel deck construction. Steering controls to be standard to brand. Powered by a gas engine of approximately 25 hp with fuel tank of approximately seven gallons. Forward groundspeed of approximately eight mph. An example of a machine meeting these specifications would be the Toro TITAN® 1500 Series Zero Turn Mower, Model 74452 or equivalent.				Each			\$ -		13
14	Zero-Turn Mowers	Zero-Turn, Sit-On with Collection Apparatus, Cut Swath of 48 to 50 inches: Cutting Swath of approximately 48 inches. Rotary blades. Steel or welded-steel deck. Hand-controlled steering levers. Powered by a gas engine of approximately 25 hp with a fuel tank of approximately seven gallons. Forward groundspeed of approximately seven mph. Includes a rear discharge and collection apparatus to collect clippings of at least nine bushels. An example of a machine meeting these specifications would be the Toro 8000 Series Model 74313 or equivalent.				Each			\$ -		14
15	Small Mowers & Grounds Tools	Narrow-Width, Push Mower, Narrow Cut Swath of 21 inches: Cutting swath of approximately 21 inches. Single rotary blade. Aluminum alloy or steel construction. Manual push driven. Powered by a small gas motor with a fuel tank of approximately one-half gallon. Either blade brake control or zone start. Rear discharge and bagging capability to ensure narrow-space mowing capability. An example of a machine meeting these specifications would be the Toro Heavy Duty, Zone Start, Toro OHV Engine, Model 22289 or equivalent.				Each			\$ -		15

Bidding Company Name:		Enter company name here				Enter catalog name here					
No.	Product Category	Product Description	Manufacturer	Manufacturer SKU	Vendor SKU	Unit of Measure	Catalog List Price	Bid Discount Percentage	Net Effective Bid Price	Comments	No.
16	Small Mowers & Grounds Tools	<p>Narrow Width, Self-Propelled Mower, California Compliant: Cutting swath of approximately 21 inches. Single rotary blade. Aluminum alloy or steel construction. Three-speed, self-propelled drive. Blade brake control. Powered by a small gas motor with a one-gallon fuel tank. Top forward ground speed of approximately four mph. Compliant with California Air Resources Board emission requirements. An example of a machine meeting these specifications would be the Toro Heavy Duty, Self-Propelled, BBC, with Kawasaki Engine Model 22298 or equivalent.</p>				Each			\$ -		16
17	Small Mowers & Grounds Tools	<p>Light-Duty, Battery-Powered Chain Saw: Suitable for large-trunked brush and tree branch trimming. Chain bar length for cutting swath of at least 14 inches. Brushless DC motor. Battery rating of 40v maximum & 36v nominal. Recharge time of approximately 60 minutes. No-pull start. An example of a machine meeting these specifications would be the Toro PowerPlex 40V MAX 14" Chainsaw Model 51880 or equivalent.</p>				Each			\$ -		17
18	Small Mowers & Grounds Tools	<p>Gas-Powered, String Trimmer: Suitable for turf edging, low-lying branches, and small shrubs. Cutting width of 18 inches. Dual-Line, bump feed cutting head. Supports minimum cord-line thickness of 2mm; straight handle. Extended reach is desirable. Powered by a small two-cycle, full-crank gas engine. Compliant with California Air Resources Board emission standards. An example of a machine meeting these specifications would be the Toro Straight Shaft Gas Trimmer Model 51978 or equivalent.</p>				Each			\$ -		18
19		<p>Gas Powered Leaf Blower: Suitable for clearing sidewalks, parking lots, planters, and small lawns. Air-power speed of approximately 150 mph. Powered by a small, commercial-grade two-cycle engine, capable of being hand carried. Motor integrated with handle; not on a backpack. Recoil starting mechanism. Includes vacuum and shredding capabilities. An example of a machine meeting these specifications would be the Toro Gas Blower Vac Model 51988 or equivalent.</p>				Each			\$ -		19



Part F.2B – Non-Core Price Schedule AEPA #020-E Lawn & Groundskeeping Equipment

INSTRUCTIONS: Download the Net Effective Bid Price and respective information for all line items except the core items (listed on F.2A) in the entire catalog. Use a separate spreadsheet for each catalog. Please be sure to set the 'Print Area' PRIOR to submitting your bid response.

NOTE: The Net Effective Price MUST be consistent with the percentage discounts listed on the F.1 tab. Failure to have price correspond may be cause for rejection of your offer.

Part F.2B is a REQUIRED FORM

Bidding Company Name:		Enter company name here				Catalog Name:			Enter catalog name here		
No.	Product Category	Product Description	Manufacturer	Manufacturer SKU	Vendor SKU	Unit of Measure	Catalog List Price	Bid Discount Percentage	Net Effective Bid Price	Comments	No.
1											1
2											2
3											3
4											4
5											5
6											6
7											7
8											8
9											9
10											10
11											11
12											12
13											13
14											14
15											15
16											16
17											17
18											18
19											19
20											20
21											21
22											22
23											23
24											24
25											25
26											26
27											27
28											28
29											29
30											30
31											31
32											32
33											33
34											34
35											35
36											36
37											37
38											38
39											39
40											40
41											41
42											42
43											43
44											44
45											45



Association of Educational
PURCHASING AGENCIES

Part F.3 – Services Price Schedule

AEPA #020-E Lawn & Groundskeeping Equipment

Bidding Company Name:

Enter company name here

NOTE: If your company provides any of the non-mandatory services listed below, please complete the price schedule.

Part F.3 is an OPTIONAL FORM

Description	Regular Price or Rates	Discounted Price or Rates	Per Diem Charges (if any)	Mileage Charges (if any)	*Additional Discount on Large Projects: Y/N

Design, Consulting, or Engineering

Description	Regular Price or Rates	Discounted Price or Rates	Per Diem Charges (if any)	Mileage Charges (if any)	*Additional Discount on Large Projects: Y/N

Installation Services

Description	Regular Price or Rates	Discounted Price or Rates	Per Diem Charges (if any)	Mileage Charges (if any)	*Additional Discount on Large Projects: Y/N

Training Services

Description	Regular Price or Rates	Discounted Price or Rates	Per Diem Charges (if any)	Mileage Charges (if any)	*Additional Discount on Large Projects: Y/N

Support Services

Description	Regular Price or Rates	Discounted Price or Rates	Per Diem Charges (if any)	Mileage Charges (if any)	*Additional Discount on Large Projects: Y/N

Repair, Break Fix or Exclusive of Parts

Turf Management		Description	Regular Price or Rates	Discounted Price or Rates	Per Diem Charges (if any)	Mileage Charges (if any)	*Additional Discount on Large Projects: Y/N

Rental Fee Schedule (if Available and Not Priced in Catalog)		Description	Regular Price or Rates	Discounted Price or Rates	Per Diem Charges (if any)	Mileage Charges (if any)	*Additional Discount on Large Projects: Y/N

Other Services		Description	Regular Price or Rates	Discounted Price or Rates	Per Diem Charges (if any)	Mileage Charges (if any)	*Additional Discount on Large Projects: Y/N

Customer Name Street Address City State Zip PO # Item # Item Description Manufacturer # Qty Extended Advertised Price Extended AEPA Price Savings

Total Purchases
Total Administrative Fee

Bid IFB #020-E - Lawn & Groundskeeping Equipment, Supplies & Services Addendum #1 - Addendum

Information Deleted: Deleted

Information Added: Added

Bid Type IFB
Bid Number 020-E
Title Lawn & Groundskeeping Equipment, Supplies & Services
Start Date Jul 22, 2019 3:01:37 PM CDT
End Date Sep 16, 2019 12:30:00 PM CDT
Agency Association of Educational Purchasing Agencies
Bid Contact Jane Eastes
 (612) 590-0066
 jeastes@lcsc.org
 1001 E. Mount Faith Avenue
 Fergus Falls, MN 56537

Description

Scope of Bid

AEPA is seeking qualified, experienced contractor(s) who possess the necessary resources and capabilities to acquire, deliver and perform the required supplies, materials, equipment and services to all participating member states (up to 28) in the category of Lawn & Groundskeeping Equipment, Supplies & Services. This invitation seeks bids for equipment, supplies, parts, and services for procurement by different types of educational, governmental, and public-benefit institutions as follows:

1. Equipment, including but not limited to zero-turn mowers; ride-on mowers; wide-area mowers; stand-on mowers; walk-behind mowers; attachable devices for cutting, aeration, and dethatching; string edgers and trimmers; chain saws; leaf and debris blowers; California compliant mowers; and utility vehicles and tractors — all offered, described, and priced in a Commercially Available Catalog.
2. Parts and supplies, including, but not limited to replacement parts, parts for customizable options and add-ons, repair parts, engine and transmission parts, tires, blades, tines, cosmetic enhancement parts, sprinkler and irrigation parts, electronic control devices, and system parts.
3. Types of services may include, but are not limited to repair services, extended maintenance contracts, landscaping and turf management software, consulting, assessments, turf management, environmental services, leasing, equipment rentals, training and professional development, and customer service.

All products offered to be sold or leased must be considered new, unused, of the latest design and technology and from the most current and popular turf and groundskeeping product lines available. Bid pricing for equipment must be for the latest available year's model. Rental equipment need not be new.

AEPA and Member Agencies prefer a single vendor with a comprehensive array of products. However, because of the unique nature of lawn and groundskeeping products and services, Member Agencies may consider multiple awards, if the lowest, best-value bids come from Bidders whose business concentrates on a subset of equipment or provides a better pricing value in the categories of 1) Small Mowers & Grounds Tools, 2) Stand-On Mowers, 3) Turf Vehicles & Attachments, 4) Walk-Behind Mowers, 5) Wide-Area Mowers, or 6) Zero-Turn Mowers. In addition, AEPA and Member Agencies reserve the right to make multiple awards in cases where more than one vendor is necessary to meet the scope of equipment needed; multiple vendors are needed to serve the geographic needs of Member Agencies; or where the majority of offerings within bidders' Commercially Available Catalog is unique from one to another.

Pre-Bid Conference

Date: Aug 14, 2019 12:00:00 PM CDT

Location: Voluntary Pre-Bid Conference Call

Notes: AEPA will host a voluntary pre-bid conference call on Wednesday, August 14, 2019, for any interested Bidders or potential Bidders. The conference call times are set in the following schedule for each of the four contiguous United States time zones. No pre-registration will be required. Recording of the conference call will be posted on the AEPA Website.

Voluntary Pre-Bid Conference Call Schedule

020-E Lawn & Groundskeeping Equipment, Supplies & Services

1:00 PM ET

12:00 PM CT

11:00 AM MT

10:00 AM PT

Join Zoom Meeting: <https://zoom.us/j/770090798>





Conference Call Number: +1 929 436 2866

Meeting ID: 770 090 798

No Attachments

Documents

Name	Posting Date	Acceptance
AEPA IFB #020-E Lawn Groundskeeping Equipment - Part A Terms and Con	Jul 22, 2019 2:41:18 PM CDT	Yes
AEPA IFB #020-E Lawn Groundskeeping Equipment - Part B Specifications -	Jul 22, 2019 2:41:22 PM CDT	Yes
AEPA IFB #020-E Lawn Groundskeeping Equipment - Part C Member Agency	Jul 22, 2019 2:41:28 PM CDT	Yes
AEPA IFB #020-E Lawn Groundskeeping Equipment - Part D Questionnaire -	Jul 22, 2019 2:41:34 PM CDT	Yes

Name	Posting Date	Acceptance
 AEPA IFB #020-E Lawn Groundskeeping Equipment - Part E Signature Form	Jul 22, 2019 2:41:39 PM CDT	Yes
 AEPA IFB #020-E Lawn Groundskeeping Equipment - Part F Discount Pricing	Jul 22, 2019 2:41:45 PM CDT	Yes
 AEPA Vendor Quarterly Report Template.pdf	Jul 22, 2019 2:41:49 PM CDT	Yes
 AEPA IFB #020-E Lawn Groundskeeping Equipment - Part C Member Agency	Aug 15, 2019 2:07:49 PM CDT	Yes
 020-E Lawn & Groundskeeping Equipment, Supplies & Services.m4a 1.0	Aug 15, 2019 2:07:54 PM CDT	No

[Return to Bid](#)

Customer Support: agencysupport@publicpurchase.com | Copyright 1999-2019 © | The Public Group, LLC. All rights reserved.

The Public | Group™

Bid IFB #020-E - Lawn & Groundskeeping Equipment, Supplies & Services Addendum #2 - Addendum

Information Deleted: Deleted

Information Added: Added

Bid Type **IFB**
 Bid Number **020-E**
 Title **Lawn & Groundskeeping Equipment, Supplies & Services**
 Start Date **Jul 22, 2019 3:01:37 PM CDT**
 End Date **Sep 16, 2019 12:30:00 PM CDT**
 Agency **Association of Educational Purchasing Agencies**
 Bid Contact **Jane Eastes**
 (612) 590-0066
 jeastes@lcsc.org
 1001 E. Mount Faith Avenue
 Fergus Falls, MN 56537

Description

Scope of Bid

AEPA is seeking qualified, experienced contractor(s) who possess the necessary resources and capabilities to acquire, deliver and perform the required supplies, materials, equipment and services to all participating member states (up to 28) in the category of Lawn & Groundskeeping Equipment, Supplies & Services. This invitation seeks bids for equipment, supplies, parts, and services for procurement by different types of educational, governmental, and public-benefit institutions as follows:

1. Equipment, including but not limited to zero-turn mowers; ride-on mowers; wide-area mowers; stand-on mowers; walk-behind mowers; attachable devices for cutting, aeration, and dethatching; string edgers and trimmers; chain saws; leaf and debris blowers; California compliant mowers; and utility vehicles and tractors — all offered, described, and priced in a Commercially Available Catalog.
2. Parts and supplies, including, but not limited to replacement parts, parts for customizable options and add-ons, repair parts, engine and transmission parts, tires, blades, tines, cosmetic enhancement parts, sprinkler and irrigation parts, electronic control devices, and system parts.
3. Types of services may include, but are not limited to repair services, extended maintenance contracts, landscaping and turf management software, consulting, assessments, turf management, environmental services, leasing, equipment rentals, training and professional development, and customer service.

All products offered to be sold or leased must be considered new, unused, of the latest design and technology and from the most current and popular turf and groundskeeping product lines available. Bid pricing for equipment must be for the latest available year's model. Rental equipment need not be new.

AEPA and Member Agencies prefer a single vendor with a comprehensive array of products. However, because of the unique nature of lawn and groundskeeping products and services, Member Agencies may consider multiple awards, if the lowest, best-value bids come from Bidders whose business concentrates on a subset of equipment or provides a better pricing value in the categories of 1) Small Mowers & Grounds Tools, 2) Stand-On Mowers, 3) Turf Vehicles & Attachments, 4) Walk-Behind Mowers, 5) Wide-Area Mowers, or 6) Zero-Turn Mowers. In addition, AEPA and Member Agencies reserve the right to make multiple awards in cases where more than one vendor is necessary to meet the scope of equipment needed; multiple vendors are needed to serve the geographic needs of Member Agencies; or where the majority of offerings within bidders' Commercially Available Catalog is unique from one to another.

Pre-Bid Conference

Date: Aug 14, 2019 12:00:00 PM CDT
 Location: Voluntary Pre-Bid Conference Call

Notes: AEPA will host a voluntary pre-bid conference call on Wednesday, August 14, 2019, for any interested Bidders or potential Bidders. The conference call times are set in the following schedule for each of the four contiguous United States time zones. No pre-registration will be required. Recording of the conference call will be posted on the AEPA Website.

Voluntary Pre-Bid Conference Call Schedule

020-E Lawn & Groundskeeping Equipment, Supplies & Services
 1:00 PM ET
 12:00 PM CT
 11:00 AM MT
 10:00 AM PT

Join Zoom Meeting: <https://zoom.us/j/770090798>
 Conference Call Number: +1 929 436 2866
 Meeting ID: 770 090 798

No Attachments

Documents

Name	Posting Date	Acceptance
AEPA IFB #020-E Lawn Groundskeeping Ec	Jul 22, 2019 2:41:18 PM CDT	Yes
AEPA IFB #020-E Lawn Groundskeeping Ec	Jul 22, 2019 2:41:22 PM CDT	Yes
AEPA IFB #020-E Lawn Groundskeeping Ec	Jul 22, 2019 2:41:34 PM CDT	Yes
AEPA IFB #020-E Lawn Groundskeeping Ec	Jul 22, 2019 2:41:39 PM CDT	Yes
AEPA IFB #020-E Lawn Groundskeeping Ec	Jul 22, 2019 2:41:45 PM CDT	Yes
AEPA Vendor Quarterly Report Template.pc	Jul 22, 2019 2:41:49 PM CDT	Yes
AEPA IFB #020-E Lawn & Grounds, Supplies & Services.m4a	Aug 15, 2019	Yes-No
AEPA IFB #020-E Lawn & Grounds	Aug 15, 2019 2:07:54 PM CDT	No
- Part C Member Agency (State) Terms and Co	Sep 10, 2019 10:41:34 AM CDT	Yes

Information Deleted: Deleted

Information Added: Added

Bid IFB #020-E - Lawn & Groundskeeping Equipment, Supplies & Services Addendum #3 - Addendum

Bid Type **IFB**
 Bid Number **020-E**
 Title **Lawn & Groundskeeping Equipment, Supplies & Services**
 Start Date **Jul 22, 2019 3:01:37 PM CDT**
 End Date **Sep 16, 2019 12:30:00 PM CDT**
 Agency **Association of Educational Purchasing Agencies**
 Bid Contact **Jane Eastes**
 (612) 590-0066
 jeastes@lcsc.org
 1001 E. Mount Faith Avenue
 Fergus Falls, MN 56537

Description

Scope of Bid

AEPA is seeking qualified, experienced contractor(s) who possess the necessary resources and capabilities to acquire, deliver and perform the required supplies, materials, equipment and services to all participating member states (up to 28) in the category of Lawn & Groundskeeping Equipment, Supplies & Services. This invitation seeks bids for equipment, supplies, parts, and services for procurement by different types of educational, governmental, and public-benefit institutions as follows:

1. Equipment, including but not limited to zero-turn mowers; ride-on mowers; wide-area mowers; stand-on mowers; walk-behind mowers; attachable devices for cutting, aeration, and dethatching; string edgers and trimmers; chain saws; leaf and debris blowers; California compliant mowers; and utility vehicles and tractors — all offered, described, and priced in a Commercially Available Catalog.
2. Parts and supplies, including, but not limited to replacement parts, parts for customizable options and add-ons, repair parts, engine and transmission parts, tires, blades, tines, cosmetic enhancement parts, sprinkler and irrigation parts, electronic control devices, and system parts.
3. Types of services may include, but are not limited to repair services, extended maintenance contracts, landscaping and turf management software, consulting, assessments, turf management, environmental services, leasing, equipment rentals, training and professional development, and customer service.

All products offered to be sold or leased must be considered new, unused, of the latest design and technology and from the most current and popular turf and groundskeeping product lines available. Bid pricing for equipment must be for the latest available year's model. Rental equipment need not be new.

AEPA and Member Agencies prefer a single vendor with a comprehensive array of products. However, because of the unique nature of lawn and groundskeeping products and services, Member Agencies may consider multiple awards, if the lowest, best-value bids come from Bidders whose business concentrates on a subset of equipment or provides a better pricing value in the categories of 1) Small Mowers & Grounds Tools, 2) Stand-On Mowers, 3) Turf Vehicles & Attachments, 4) Walk-Behind Mowers, 5) Wide-Area Mowers, or 6) Zero-Turn Mowers. In addition, AEPA and Member Agencies reserve the right to make multiple awards in cases where more than one vendor is necessary to meet the scope of equipment needed; multiple vendors are needed to serve the geographic needs of Member Agencies; or where the majority of offerings within bidders' Commercially Available Catalog is unique from one to another.

Pre-Bid Conference

Date: Aug 14, 2019 12:00:00 PM CDT

Location: Voluntary Pre-Bid Conference Call

Notes: AEPA will host a voluntary pre-bid conference call on Wednesday, August 14, 2019, for any interested Bidders or potential Bidders. The conference call times are set in the following schedule for each of the four contiguous United States time zones. No pre-registration will be required. Recording of the conference call will be posted on the AEPA Website.

Voluntary Pre-Bid Conference Call Schedule

020-E Lawn & Groundskeeping Equipment, Supplies & Services

1:00 PM ET

12:00 PM CT

11:00 AM MT

10:00 AM PT









Join Zoom Meeting: <https://zoom.us/j/770090798>

Conference Call Number: +1 929 436 2866

Meeting ID: 770 090 798

No Attachments

Documents

Name	Posting Date	Acceptance
 AEPA IFB #020-E Lawn Groundskeeping Equipment - Part A Terms and Conditions - FINA	Jul 22, 2019 2:41:18 PM CDT	Yes
 AEPA IFB #020-E Lawn Groundskeeping Equipment - Part B Specifications - FINAL.pdf	Jul 22, 2019 2:41:22 PM CDT	Yes
 AEPA IFB #020-E Lawn Groundskeeping Equipment - Part D Questionnaire - FINAL.docx	Jul 22, 2019 2:41:34 PM CDT	Yes
 AEPA IFB #020-E Lawn Groundskeeping Equipment - Part E Signature Forms - FINAL.pdf	Jul 22, 2019 2:41:39 PM CDT	Yes
 AEPA IFB #020-E Lawn Groundskeeping Equipment - Part F Discount Pricing Workbook -	Jul 22, 2019 2:41:45 PM CDT	Yes
 AEPA Vendor Quarterly Report Template.pdf	Jul 22, 2019 2:41:49 PM CDT	Yes
 020-E Lawn & Groundskeeping Equipment, Supplies & Services.m4a 1.0	Aug 15, 2019 2:07:54 PM CDT	No
 AEPA IFB #020-E Lawn Groundskeeping Equipment - Part C Member Agency (State) Tern Sep 10 2013, 2019 10:44:37:34 AM-22 P		Yes

From: [Public Purchase](#)
To: [Lisa Truax](#)
Subject: Public Purchase - IFB #020-E - Lawn & Groundskeeping Equipment, Supplies & Services Closed Notification
Date: Monday, September 16, 2019 12:30:28 PM

Lisa Truax:

The bid IFB #020-E - Lawn & Groundskeeping Equipment, Supplies & Services has closed on Sep 16, 2019 11:30:00 AM MDT

To see more details on this bid go to

<http://www.publicpurchase.com/gems/bid/bidView?bidId=115756>

Thank you for using Public Purchase.

MK= RHG4JeQOe2olg+hP63mZiQ==

Notifications Report

Agency
Bid Number
Bid Title

Association of Educational Purchasing Agencies
020-E
Lawn & Groundskeeping Equipment, Supplies & Services

Vendor Name	State	Invitation	Date	Email	Reason
ACS Landscape Management	GA	Self Invited	2019-08-15 13:22:12	joey@acslandscapemanagement.com	Addendum Notification
ACS Landscape Management	GA	Self Invited	2019-08-21 08:44:43	joey@acslandscapemanagement.com	Bid Answer
ACS Landscape Management	GA	Self Invited	2019-08-26 14:08:46	joey@acslandscapemanagement.com	Bid Answer
ACS Landscape Management	GA	Self Invited	2019-08-26 14:09:15	joey@acslandscapemanagement.com	Bid Answer
ACS Landscape Management	GA	Self Invited	2019-08-26 14:09:38	joey@acslandscapemanagement.com	Bid Answer
ACS Landscape Management	GA	Self Invited	2019-08-26 14:09:57	joey@acslandscapemanagement.com	Bid Answer
ACS Landscape Management	GA	Self Invited	2019-08-26 14:10:20	joey@acslandscapemanagement.com	Bid Answer
ACS Landscape Management	GA	Self Invited	2019-08-30 15:34:30	joey@acslandscapemanagement.com	Bid Answer
ACS Landscape Management	GA	Self Invited	2019-09-10 09:57:05	joey@acslandscapemanagement.com	Addendum Notification
ACS Landscape Management	GA	Self Invited	2019-09-13 12:50:00	joey@acslandscapemanagement.com	Addendum Notification
ACS Landscape Management	GA	Self Invited	2019-09-13 13:49:31	joey@acslandscapemanagement.com	Bid Answer
AEPA PAEC	FL	Self Invited	2019-08-26 14:08:46	judy.hall@paec.org	Bid Answer
AEPA PAEC	FL	Self Invited	2019-08-26 14:09:15	judy.hall@paec.org	Bid Answer
AEPA PAEC	FL	Self Invited	2019-08-26 14:09:38	judy.hall@paec.org	Bid Answer
AEPA PAEC	FL	Self Invited	2019-08-26 14:09:57	judy.hall@paec.org	Bid Answer
AEPA PAEC	FL	Self Invited	2019-08-26 14:10:20	judy.hall@paec.org	Bid Answer
AEPA PAEC	FL	Self Invited	2019-08-30 15:34:30	judy.hall@paec.org	Bid Answer
AEPA PAEC	FL	Self Invited	2019-09-10 09:57:05	judy.hall@paec.org	Addendum Notification
AEPA PAEC	FL	Self Invited	2019-09-13 12:50:00	judy.hall@paec.org	Addendum Notification
AEPA PAEC	FL	Self Invited	2019-09-13 13:49:31	judy.hall@paec.org	Bid Answer
Allied Construction Industries	OH	Self Invited	2019-08-15 13:22:12	dwright@aci-construction.org	Addendum Notification
Allied Construction Industries	OH	Self Invited	2019-08-21 08:44:43	dwright@aci-construction.org	Bid Answer
Allied Construction Industries	OH	Self Invited	2019-08-26 14:08:46	dwright@aci-construction.org	Bid Answer
Allied Construction Industries	OH	Self Invited	2019-08-26 14:09:15	dwright@aci-construction.org	Bid Answer
Allied Construction Industries	OH	Self Invited	2019-08-26 14:09:38	dwright@aci-construction.org	Bid Answer
Allied Construction Industries	OH	Self Invited	2019-08-26 14:09:57	dwright@aci-construction.org	Bid Answer
Allied Construction Industries	OH	Self Invited	2019-08-26 14:10:20	dwright@aci-construction.org	Bid Answer
Allied Construction Industries	OH	Self Invited	2019-08-30 15:34:30	dwright@aci-construction.org	Bid Answer
Allied Construction Industries	OH	Self Invited	2019-09-10 09:57:05	dwright@aci-construction.org	Addendum Notification
Allied Construction Industries	OH	Self Invited	2019-09-13 12:50:00	dwright@aci-construction.org	Addendum Notification
Allied Construction Industries	OH	Self Invited	2019-09-13 13:49:31	dwright@aci-construction.org	Bid Answer
Altoz, Inc.	MN	Invited	2019-08-02 14:56:58	carmen.solom@altoz.com	Bid Notification
bobcat company	ND	Self Invited	2019-08-15 13:22:12	Jesse.Rheault@doosan.com	Addendum Notification
bobcat company	ND	Self Invited	2019-08-21 08:44:43	Jesse.Rheault@doosan.com	Bid Answer
bobcat company	ND	Self Invited	2019-08-26 14:08:46	Jesse.Rheault@doosan.com	Bid Answer
bobcat company	ND	Self Invited	2019-08-26 14:09:15	Jesse.Rheault@doosan.com	Bid Answer
bobcat company	ND	Self Invited	2019-08-26 14:09:38	Jesse.Rheault@doosan.com	Bid Answer
bobcat company	ND	Self Invited	2019-08-26 14:09:57	Jesse.Rheault@doosan.com	Bid Answer
bobcat company	ND	Self Invited	2019-08-26 14:10:20	Jesse.Rheault@doosan.com	Bid Answer
bobcat company	ND	Self Invited	2019-08-30 15:34:30	Jesse.Rheault@doosan.com	Bid Answer
bobcat company	ND	Self Invited	2019-09-10 09:57:05	Jesse.Rheault@doosan.com	Addendum Notification
bobcat company	ND	Self Invited	2019-09-13 12:50:00	Jesse.Rheault@doosan.com	Addendum Notification
bobcat company	ND	Self Invited	2019-09-13 13:49:31	Jesse.Rheault@doosan.com	Bid Answer
Deere & Company	NC	Self Invited	2019-08-15 13:22:12	GNSBids@JohnDeere.com	Addendum Notification
Deere & Company	NC	Self Invited	2019-08-21 08:44:43	GNSBids@JohnDeere.com	Bid Answer
Deere & Company	NC	Self Invited	2019-08-26 14:08:46	GNSBids@JohnDeere.com	Bid Answer
Deere & Company	NC	Self Invited	2019-08-26 14:09:15	GNSBids@JohnDeere.com	Bid Answer
Deere & Company	NC	Self Invited	2019-08-26 14:09:38	GNSBids@JohnDeere.com	Bid Answer
Deere & Company	NC	Self Invited	2019-08-26 14:09:57	GNSBids@JohnDeere.com	Bid Answer
Deere & Company	NC	Self Invited	2019-08-26 14:10:20	GNSBids@JohnDeere.com	Bid Answer
Deere & Company	NC	Self Invited	2019-08-30 15:34:30	GNSBids@JohnDeere.com	Bid Answer
Deere & Company	NC	Self Invited	2019-09-10 09:57:05	GNSBids@JohnDeere.com	Addendum Notification
Deere & Company	NC	Self Invited	2019-09-10 09:57:05	govcontractsupport@johndeere.com	Addendum Notification
Deere & Company	NC	Self Invited	2019-09-13 12:50:00	GNSBids@JohnDeere.com	Addendum Notification
Deere & Company	NC	Self Invited	2019-09-13 12:50:00	govcontractsupport@johndeere.com	Addendum Notification
Deere & Company	NC	Self Invited	2019-09-13 13:49:31	GNSBids@JohnDeere.com	Bid Answer
Deere & Company	NC	Self Invited	2019-09-13 13:49:31	govcontractsupport@johndeere.com	Bid Answer
Distributors Hardware Inc	IL	Classification	2019-07-22 17:52:14	kcrawley@truevalue.com	Bid Notification
Dodge Data & Analytics	TX	Self Invited	2019-08-15 13:22:12	dodge.docs@construction.com	Addendum Notification
Dodge Data & Analytics	TX	Self Invited	2019-08-21 08:44:43	dodge.docs@construction.com	Bid Answer
Dodge Data & Analytics	TX	Self Invited	2019-08-26 14:08:46	dodge.docs@construction.com	Bid Answer
Dodge Data & Analytics	TX	Self Invited	2019-08-26 14:09:15	dodge.docs@construction.com	Bid Answer
Dodge Data & Analytics	TX	Self Invited	2019-08-26 14:09:38	dodge.docs@construction.com	Bid Answer
Dodge Data & Analytics	TX	Self Invited	2019-08-26 14:09:57	dodge.docs@construction.com	Bid Answer
Dodge Data & Analytics	TX	Self Invited	2019-08-26 14:10:20	dodge.docs@construction.com	Bid Answer
Dodge Data & Analytics	TX	Self Invited	2019-08-30 15:34:30	dodge.docs@construction.com	Bid Answer
Dodge Data & Analytics	TX	Self Invited	2019-09-10 09:57:05	dodge.docs@construction.com	Addendum Notification
Dodge Data & Analytics	TX	Self Invited	2019-09-13 12:50:00	dodge.docs@construction.com	Addendum Notification

Dodge Data & Analytics	TX	Self Invited	2019-09-13 13:49:31	dodge.docs@construction.com	Bid Answer
Gambrills Equipment Company Inc	MD	Self Invited	2019-08-15 13:22:12	jim.nolan@sawdocmd.com	Addendum Notification
Gambrills Equipment Company Inc	MD	Self Invited	2019-08-21 08:44:43	jim.nolan@sawdocmd.com	Bid Answer
Gambrills Equipment Company Inc	MD	Self Invited	2019-08-26 14:08:46	jim.nolan@sawdocmd.com	Bid Answer
Gambrills Equipment Company Inc	MD	Self Invited	2019-08-26 14:09:15	jim.nolan@sawdocmd.com	Bid Answer
Gambrills Equipment Company Inc	MD	Self Invited	2019-08-26 14:09:38	jim.nolan@sawdocmd.com	Bid Answer
Gambrills Equipment Company Inc	MD	Self Invited	2019-08-26 14:09:57	jim.nolan@sawdocmd.com	Bid Answer
Gambrills Equipment Company Inc	MD	Self Invited	2019-08-26 14:10:20	jim.nolan@sawdocmd.com	Bid Answer
Gambrills Equipment Company Inc	MD	Self Invited	2019-08-30 15:34:30	jim.nolan@sawdocmd.com	Bid Answer
Gambrills Equipment Company Inc	MD	Self Invited	2019-09-10 09:57:05	jim.nolan@sawdocmd.com	Addendum Notification
Gambrills Equipment Company Inc	MD	Self Invited	2019-09-13 12:50:00	jim.nolan@sawdocmd.com	Addendum Notification
Gambrills Equipment Company Inc	MD	Self Invited	2019-09-13 13:49:31	jim.nolan@sawdocmd.com	Bid Answer
Husqvarna Professional Products, Inc.	NC	Classification	2019-07-25 10:35:22	jake.breig@husqvarnagroup.com	Bid Notification
Husqvarna Professional Products, Inc.	NC	Classification	2019-08-15 13:22:12	jake.breig@husqvarnagroup.com	Addendum Notification
Husqvarna Professional Products, Inc.	NC	Classification	2019-08-21 08:44:43	jake.breig@husqvarnagroup.com	Bid Answer
Husqvarna Professional Products, Inc.	NC	Classification	2019-08-26 14:08:46	jake.breig@husqvarnagroup.com	Bid Answer
Husqvarna Professional Products, Inc.	NC	Classification	2019-08-26 14:09:14	jake.breig@husqvarnagroup.com	Bid Answer
Husqvarna Professional Products, Inc.	NC	Classification	2019-08-26 14:09:38	jake.breig@husqvarnagroup.com	Bid Answer
Husqvarna Professional Products, Inc.	NC	Classification	2019-08-26 14:09:57	jake.breig@husqvarnagroup.com	Bid Answer
Husqvarna Professional Products, Inc.	NC	Classification	2019-08-26 14:10:20	jake.breig@husqvarnagroup.com	Bid Answer
Husqvarna Professional Products, Inc.	NC	Classification	2019-08-30 15:34:30	jake.breig@husqvarnagroup.com	Bid Answer
Husqvarna Professional Products, Inc.	NC	Classification	2019-09-10 09:57:05	jake.breig@husqvarnagroup.com	Addendum Notification
Husqvarna Professional Products, Inc.	NC	Classification	2019-09-13 12:50:00	jake.breig@husqvarnagroup.com	Addendum Notification
Husqvarna Professional Products, Inc.	NC	Classification	2019-09-13 13:49:31	jake.breig@husqvarnagroup.com	Bid Answer
Hustler Turf Equipment	KS	Classification	2019-08-27 14:20:56	brian.odonnell@excelii.com	Bid Notification
Hustler Turf Equipment	KS	Classification	2019-08-30 15:34:30	brian.odonnell@excelii.com	Bid Answer
Hustler Turf Equipment	KS	Classification	2019-09-10 09:57:05	brian.odonnell@excelii.com	Addendum Notification
Hustler Turf Equipment	KS	Classification	2019-09-13 12:50:00	brian.odonnell@excelii.com	Addendum Notification
Hustler Turf Equipment	KS	Classification	2019-09-13 13:49:31	brian.odonnell@excelii.com	Bid Answer
John Tortelli	NM	Self Invited	2019-08-15 13:22:12	jntortelli@yahoo.com	Addendum Notification
John Tortelli	NM	Self Invited	2019-08-21 08:44:43	jntortelli@yahoo.com	Bid Answer
John Tortelli	NM	Self Invited	2019-08-26 14:08:46	jntortelli@yahoo.com	Bid Answer
John Tortelli	NM	Self Invited	2019-08-26 14:09:15	jntortelli@yahoo.com	Bid Answer
John Tortelli	NM	Self Invited	2019-08-26 14:09:38	jntortelli@yahoo.com	Bid Answer
John Tortelli	NM	Self Invited	2019-08-26 14:09:57	jntortelli@yahoo.com	Bid Answer
John Tortelli	NM	Self Invited	2019-08-26 14:10:20	jntortelli@yahoo.com	Bid Answer
John Tortelli	NM	Self Invited	2019-08-30 15:34:30	jntortelli@yahoo.com	Bid Answer
John Tortelli	NM	Self Invited	2019-09-10 09:57:05	jntortelli@yahoo.com	Addendum Notification
John Tortelli	NM	Self Invited	2019-09-13 12:50:00	jntortelli@yahoo.com	Addendum Notification
John Tortelli	NM	Self Invited	2019-09-13 13:49:31	jntortelli@yahoo.com	Bid Answer
Lawson Products Inc	IL	Self Invited	2019-08-15 13:22:12	govsales@lawsonproducts.com	Addendum Notification
Lawson Products Inc	IL	Self Invited	2019-08-21 08:44:43	govsales@lawsonproducts.com	Bid Answer
Lawson Products Inc	IL	Self Invited	2019-08-26 14:08:46	govsales@lawsonproducts.com	Bid Answer
Lawson Products Inc	IL	Self Invited	2019-08-26 14:09:15	govsales@lawsonproducts.com	Bid Answer
Lawson Products Inc	IL	Self Invited	2019-08-26 14:09:38	govsales@lawsonproducts.com	Bid Answer
Lawson Products Inc	IL	Self Invited	2019-08-26 14:09:57	govsales@lawsonproducts.com	Bid Answer
Lawson Products Inc	IL	Self Invited	2019-08-26 14:10:20	govsales@lawsonproducts.com	Bid Answer
Lawson Products Inc	IL	Self Invited	2019-08-30 15:34:30	govsales@lawsonproducts.com	Bid Answer
Lawson Products Inc	IL	Self Invited	2019-09-10 09:57:05	govsales@lawsonproducts.com	Addendum Notification
Lawson Products Inc	IL	Self Invited	2019-09-13 12:50:00	govsales@lawsonproducts.com	Addendum Notification
Lawson Products Inc	IL	Self Invited	2019-09-13 13:49:31	govsales@lawsonproducts.com	Bid Answer
L&L Supplies	TX	Self Invited	2019-08-26 14:08:46	swalker8585@gmail.com	Bid Answer
L&L Supplies	TX	Self Invited	2019-08-26 14:09:15	swalker8585@gmail.com	Bid Answer
L&L Supplies	TX	Self Invited	2019-08-26 14:09:38	swalker8585@gmail.com	Bid Answer
L&L Supplies	TX	Self Invited	2019-08-26 14:09:57	swalker8585@gmail.com	Bid Answer
L&L Supplies	TX	Self Invited	2019-08-26 14:10:20	swalker8585@gmail.com	Bid Answer
L&L Supplies	TX	Self Invited	2019-08-30 15:34:30	swalker8585@gmail.com	Bid Answer
L&L Supplies	TX	Self Invited	2019-09-10 09:57:05	swalker8585@gmail.com	Addendum Notification
L&L Supplies	TX	Self Invited	2019-09-13 12:50:00	swalker8585@gmail.com	Addendum Notification
L&L Supplies	TX	Self Invited	2019-09-13 13:49:31	swalker8585@gmail.com	Bid Answer
Makita U.S.A., Inc.	CA	Classification	2019-07-31 11:57:51	cchapman@makitausea.com	Bid Notification
Makita U.S.A., Inc.	CA	Classification	2019-08-15 13:22:12	cchapman@makitausea.com	Addendum Notification
Makita U.S.A., Inc.	CA	Classification	2019-08-21 08:44:43	cchapman@makitausea.com	Bid Answer
Makita U.S.A., Inc.	CA	Classification	2019-08-26 14:08:46	cchapman@makitausea.com	Bid Answer
Makita U.S.A., Inc.	CA	Classification	2019-08-26 14:09:15	cchapman@makitausea.com	Bid Answer
Makita U.S.A., Inc.	CA	Classification	2019-08-26 14:09:38	cchapman@makitausea.com	Bid Answer
Makita U.S.A., Inc.	CA	Classification	2019-08-26 14:09:57	cchapman@makitausea.com	Bid Answer
Makita U.S.A., Inc.	CA	Classification	2019-08-26 14:10:20	cchapman@makitausea.com	Bid Answer
Makita U.S.A., Inc.	CA	Classification	2019-08-30 15:34:30	cchapman@makitausea.com	Bid Answer
Makita U.S.A., Inc.	CA	Classification	2019-09-10 09:57:05	cchapman@makitausea.com	Addendum Notification
Makita U.S.A., Inc.	CA	Classification	2019-09-13 12:50:00	cchapman@makitausea.com	Addendum Notification
Makita U.S.A., Inc.	CA	Classification	2019-09-13 13:49:31	cchapman@makitausea.com	Bid Answer
Marion Ford Tractor, Inc.	GA	Classification	2019-08-02 14:57:01	jlashley@lashleyts.com	Bid Notification
Marion Ford Tractor, Inc.	GA	Classification	2019-08-15 13:22:12	jlashley@lashleyts.com	Addendum Notification
Marion Ford Tractor, Inc.	GA	Classification	2019-08-21 08:44:43	jlashley@lashleyts.com	Bid Answer

Marion Ford Tractor, Inc.	GA	Classification	2019-08-26 14:08:46	jlashley@lashleyts.com	Bid Answer
Marion Ford Tractor, Inc.	GA	Classification	2019-08-26 14:09:15	jlashley@lashleyts.com	Bid Answer
Marion Ford Tractor, Inc.	GA	Classification	2019-08-26 14:09:38	jlashley@lashleyts.com	Bid Answer
Marion Ford Tractor, Inc.	GA	Classification	2019-08-26 14:09:57	jlashley@lashleyts.com	Bid Answer
Marion Ford Tractor, Inc.	GA	Classification	2019-08-26 14:10:20	jlashley@lashleyts.com	Bid Answer
Marion Ford Tractor, Inc.	GA	Classification	2019-08-30 15:34:30	jlashley@lashleyts.com	Bid Answer
Marion Ford Tractor, Inc.	GA	Classification	2019-09-10 09:57:05	jlashley@lashleyts.com	Addendum Notification
Marion Ford Tractor, Inc.	GA	Classification	2019-09-13 12:50:00	jlashley@lashleyts.com	Addendum Notification
Marion Ford Tractor, Inc.	GA	Classification	2019-09-13 13:49:31	jlashley@lashleyts.com	Bid Answer
Mick Rich Contractors, Inc	NM	Self Invited	2019-08-15 13:22:12	sandra@mickrichcontractors.com	Addendum Notification
Mick Rich Contractors, Inc	NM	Self Invited	2019-08-21 08:44:43	sandra@mickrichcontractors.com	Bid Answer
Mick Rich Contractors, Inc	NM	Self Invited	2019-08-26 14:08:46	sandra@mickrichcontractors.com	Bid Answer
Mick Rich Contractors, Inc	NM	Self Invited	2019-08-26 14:09:15	sandra@mickrichcontractors.com	Bid Answer
Mick Rich Contractors, Inc	NM	Self Invited	2019-08-26 14:09:38	sandra@mickrichcontractors.com	Bid Answer
Mick Rich Contractors, Inc	NM	Self Invited	2019-08-26 14:09:57	sandra@mickrichcontractors.com	Bid Answer
Mick Rich Contractors, Inc	NM	Self Invited	2019-08-26 14:10:20	sandra@mickrichcontractors.com	Bid Answer
Mick Rich Contractors, Inc	NM	Self Invited	2019-08-30 15:34:30	sandra@mickrichcontractors.com	Bid Answer
Mick Rich Contractors, Inc	NM	Self Invited	2019-09-10 09:57:05	sandra@mickrichcontractors.com	Addendum Notification
Mick Rich Contractors, Inc	NM	Self Invited	2019-09-13 12:50:00	sandra@mickrichcontractors.com	Addendum Notification
Mick Rich Contractors, Inc	NM	Self Invited	2019-09-13 13:49:31	sandra@mickrichcontractors.com	Bid Answer
Monroe Tractor	CT	Self Invited	2019-08-15 13:22:12	crobbins@monroetractor.com	Addendum Notification
Monroe Tractor	CT	Self Invited	2019-08-21 08:44:43	crobbins@monroetractor.com	Bid Answer
Monroe Tractor	CT	Self Invited	2019-08-26 14:08:46	crobbins@monroetractor.com	Bid Answer
Monroe Tractor	CT	Self Invited	2019-08-26 14:09:15	crobbins@monroetractor.com	Bid Answer
Monroe Tractor	CT	Self Invited	2019-08-26 14:09:38	crobbins@monroetractor.com	Bid Answer
Monroe Tractor	CT	Self Invited	2019-08-26 14:09:57	crobbins@monroetractor.com	Bid Answer
Monroe Tractor	CT	Self Invited	2019-08-26 14:10:20	crobbins@monroetractor.com	Bid Answer
Monroe Tractor	CT	Self Invited	2019-08-30 15:34:30	crobbins@monroetractor.com	Bid Answer
Monroe Tractor	CT	Self Invited	2019-09-10 09:57:05	crobbins@monroetractor.com	Addendum Notification
Monroe Tractor	CT	Self Invited	2019-09-13 12:50:00	crobbins@monroetractor.com	Addendum Notification
Monroe Tractor	CT	Self Invited	2019-09-13 13:49:31	crobbins@monroetractor.com	Bid Answer
Moridge Manufacturing Inc.	KS	Self Invited	2019-08-15 13:22:12	bdobson@grasshoppermower.com	Addendum Notification
Moridge Manufacturing Inc.	KS	Self Invited	2019-08-21 08:44:43	bdobson@grasshoppermower.com	Bid Answer
Moridge Manufacturing Inc.	KS	Self Invited	2019-08-26 14:08:46	bdobson@grasshoppermower.com	Bid Answer
Moridge Manufacturing Inc.	KS	Self Invited	2019-08-26 14:09:15	bdobson@grasshoppermower.com	Bid Answer
Moridge Manufacturing Inc.	KS	Self Invited	2019-08-26 14:09:38	bdobson@grasshoppermower.com	Bid Answer
Moridge Manufacturing Inc.	KS	Self Invited	2019-08-26 14:09:57	bdobson@grasshoppermower.com	Bid Answer
Moridge Manufacturing Inc.	KS	Self Invited	2019-08-26 14:10:20	bdobson@grasshoppermower.com	Bid Answer
Moridge Manufacturing Inc.	KS	Self Invited	2019-08-30 15:34:30	bdobson@grasshoppermower.com	Bid Answer
Moridge Manufacturing Inc.	KS	Self Invited	2019-09-10 09:57:05	bdobson@grasshoppermower.com	Addendum Notification
Moridge Manufacturing Inc.	KS	Self Invited	2019-09-13 12:50:00	bdobson@grasshoppermower.com	Addendum Notification
Moridge Manufacturing Inc.	KS	Self Invited	2019-09-13 13:49:31	bdobson@grasshoppermower.com	Bid Answer
Nationwide Wholesale Direct	IA	Classification	2019-07-22 17:52:14	nationwidewholesaledirect@msn.com	Bid Notification
North America Procurement Council	CO	Self Invited	2019-08-15 13:22:12	sourcemanagement@nampc.me	Addendum Notification
North America Procurement Council	CO	Self Invited	2019-08-21 08:44:43	sourcemanagement@nampc.me	Bid Answer
North America Procurement Council	CO	Self Invited	2019-08-26 14:08:46	sourcemanagement@nampc.me	Bid Answer
North America Procurement Council	CO	Self Invited	2019-08-26 14:09:15	sourcemanagement@nampc.me	Bid Answer
North America Procurement Council	CO	Self Invited	2019-08-26 14:09:38	sourcemanagement@nampc.me	Bid Answer
North America Procurement Council	CO	Self Invited	2019-08-26 14:09:57	sourcemanagement@nampc.me	Bid Answer
North America Procurement Council	CO	Self Invited	2019-08-26 14:10:20	sourcemanagement@nampc.me	Bid Answer
North America Procurement Council	CO	Self Invited	2019-08-30 15:34:30	sourcemanagement@nampc.me	Bid Answer
North America Procurement Council	CO	Self Invited	2019-09-10 09:57:05	sourcemanagement@nampc.me	Addendum Notification
North America Procurement Council	CO	Self Invited	2019-09-13 12:50:00	sourcemanagement@nampc.me	Addendum Notification
North America Procurement Council	CO	Self Invited	2019-09-13 13:49:31	sourcemanagement@nampc.me	Bid Answer
Onvia	WA	Self Invited	2019-08-15 13:22:12	sourcemanagement2@onvia.com	Addendum Notification
Onvia	WA	Self Invited	2019-08-21 08:44:43	sourcemanagement2@onvia.com	Bid Answer
Onvia	WA	Self Invited	2019-08-26 14:08:46	sourcemanagement2@onvia.com	Bid Answer
Onvia	WA	Self Invited	2019-08-26 14:09:15	sourcemanagement2@onvia.com	Bid Answer
Onvia	WA	Self Invited	2019-08-26 14:09:38	sourcemanagement2@onvia.com	Bid Answer
Onvia	WA	Self Invited	2019-08-26 14:09:57	sourcemanagement2@onvia.com	Bid Answer
Onvia	WA	Self Invited	2019-08-26 14:10:20	sourcemanagement2@onvia.com	Bid Answer
Onvia	WA	Self Invited	2019-08-30 15:34:30	sourcemanagement2@onvia.com	Bid Answer
Onvia	WA	Self Invited	2019-09-10 09:57:05	sourcemanagement2@onvia.com	Addendum Notification
Onvia	WA	Self Invited	2019-09-13 12:50:00	sourcemanagement2@onvia.com	Addendum Notification
Onvia	WA	Self Invited	2019-09-13 13:49:31	sourcemanagement2@onvia.com	Bid Answer
Pathfinder Tree Service, LLC	MA	Self Invited	2019-08-15 13:22:12	lauren@pathfindertreeservice.com	Addendum Notification
Pathfinder Tree Service, LLC	MA	Self Invited	2019-08-21 08:44:43	lauren@pathfindertreeservice.com	Bid Answer
Pathfinder Tree Service, LLC	MA	Self Invited	2019-08-26 14:08:46	lauren@pathfindertreeservice.com	Bid Answer
Pathfinder Tree Service, LLC	MA	Self Invited	2019-08-26 14:09:15	lauren@pathfindertreeservice.com	Bid Answer
Pathfinder Tree Service, LLC	MA	Self Invited	2019-08-26 14:09:38	lauren@pathfindertreeservice.com	Bid Answer
Pathfinder Tree Service, LLC	MA	Self Invited	2019-08-26 14:09:57	lauren@pathfindertreeservice.com	Bid Answer
Pathfinder Tree Service, LLC	MA	Self Invited	2019-08-26 14:10:20	lauren@pathfindertreeservice.com	Bid Answer
Pathfinder Tree Service, LLC	MA	Self Invited	2019-08-30 15:34:30	lauren@pathfindertreeservice.com	Bid Answer
Pathfinder Tree Service, LLC	MA	Self Invited	2019-09-10 09:57:05	lauren@pathfindertreeservice.com	Addendum Notification
Pathfinder Tree Service, LLC	MA	Self Invited	2019-09-13 12:50:00	lauren@pathfindertreeservice.com	Addendum Notification

Pathfinder Tree Service, LLC	MA	Self Invited	2019-09-13 13:49:31	lauren@pathfindertreeservice.com	Bid Answer
Royal Media Network Inc.	MD	Classification	2019-07-22 17:52:14	lorence@royalimagingolutions.com	Bid Notification
SafetyFirst Playground Surfacing LLC	MN	Self Invited	2019-08-15 13:22:12	marissa.bauer@safetyfirstplayground.com	Addendum Notification
SafetyFirst Playground Surfacing LLC	MN	Self Invited	2019-08-21 08:44:43	marissa.bauer@safetyfirstplayground.com	Bid Answer
SafetyFirst Playground Surfacing LLC	MN	Self Invited	2019-08-26 14:08:46	marissa.bauer@safetyfirstplayground.com	Bid Answer
SafetyFirst Playground Surfacing LLC	MN	Self Invited	2019-08-26 14:09:15	marissa.bauer@safetyfirstplayground.com	Bid Answer
SafetyFirst Playground Surfacing LLC	MN	Self Invited	2019-08-26 14:09:38	marissa.bauer@safetyfirstplayground.com	Bid Answer
SafetyFirst Playground Surfacing LLC	MN	Self Invited	2019-08-26 14:09:57	marissa.bauer@safetyfirstplayground.com	Bid Answer
SafetyFirst Playground Surfacing LLC	MN	Self Invited	2019-08-26 14:10:20	marissa.bauer@safetyfirstplayground.com	Bid Answer
SafetyFirst Playground Surfacing LLC	MN	Self Invited	2019-08-30 15:34:30	marissa.bauer@safetyfirstplayground.com	Bid Answer
SafetyFirst Playground Surfacing LLC	MN	Self Invited	2019-09-10 09:57:05	marissa.bauer@safetyfirstplayground.com	Addendum Notification
SafetyFirst Playground Surfacing LLC	MN	Self Invited	2019-09-13 12:50:00	marissa.bauer@safetyfirstplayground.com	Addendum Notification
SafetyFirst Playground Surfacing, LLC	MN	Self Invited	2019-08-21 08:44:43	office.manager@safetyfirstplayground.com	Bid Answer
SafetyFirst Playground Surfacing, LLC	MN	Self Invited	2019-08-26 14:08:46	office.manager@safetyfirstplayground.com	Bid Answer
SafetyFirst Playground Surfacing, LLC	MN	Self Invited	2019-08-26 14:09:15	office.manager@safetyfirstplayground.com	Bid Answer
SafetyFirst Playground Surfacing, LLC	MN	Self Invited	2019-08-26 14:09:38	office.manager@safetyfirstplayground.com	Bid Answer
SafetyFirst Playground Surfacing, LLC	MN	Self Invited	2019-08-26 14:09:57	office.manager@safetyfirstplayground.com	Bid Answer
SafetyFirst Playground Surfacing, LLC	MN	Self Invited	2019-08-26 14:10:20	office.manager@safetyfirstplayground.com	Bid Answer
SafetyFirst Playground Surfacing, LLC	MN	Self Invited	2019-08-30 15:34:30	office.manager@safetyfirstplayground.com	Bid Answer
SafetyFirst Playground Surfacing, LLC	MN	Self Invited	2019-09-10 09:57:05	office.manager@safetyfirstplayground.com	Addendum Notification
SafetyFirst Playground Surfacing, LLC	MN	Self Invited	2019-09-13 12:50:00	office.manager@safetyfirstplayground.com	Addendum Notification
SafetyFirst Playground Surfacing, LLC	MN	Self Invited	2019-09-13 13:49:31	office.manager@safetyfirstplayground.com	Bid Answer
SafetyFirst Playground Surfacing, LLC	MN	Self Invited	2019-09-13 13:50:25	office.manager@safetyfirstplayground.com	Bid Answer
SmartProcure	FL	Self Invited	2019-08-15 13:22:12	jeff@smartprocure.us	Addendum Notification
SmartProcure	FL	Self Invited	2019-08-21 08:44:43	jeff@smartprocure.us	Bid Answer
SmartProcure	FL	Self Invited	2019-08-26 14:08:46	jeff@smartprocure.us	Bid Answer
SmartProcure	FL	Self Invited	2019-08-26 14:09:15	jeff@smartprocure.us	Bid Answer
SmartProcure	FL	Self Invited	2019-08-26 14:09:38	jeff@smartprocure.us	Bid Answer
SmartProcure	FL	Self Invited	2019-08-26 14:09:57	jeff@smartprocure.us	Bid Answer
SmartProcure	FL	Self Invited	2019-08-26 14:10:20	jeff@smartprocure.us	Bid Answer
SmartProcure	FL	Self Invited	2019-08-30 15:34:30	jeff@smartprocure.us	Bid Answer
SmartProcure	FL	Self Invited	2019-09-10 09:57:05	jeff@smartprocure.us	Addendum Notification
SmartProcure	FL	Self Invited	2019-09-13 12:50:00	jeff@smartprocure.us	Addendum Notification
SmartProcure	FL	Self Invited	2019-09-13 13:49:31	jeff@smartprocure.us	Bid Answer
SMG Equipment LLC	WA	Self Invited	2019-08-21 08:44:43	info@smgequipment.com	Bid Answer
SMG Equipment LLC	WA	Self Invited	2019-08-26 14:08:46	info@smgequipment.com	Bid Answer
SMG Equipment LLC	WA	Self Invited	2019-08-26 14:09:15	info@smgequipment.com	Bid Answer
SMG Equipment LLC	WA	Self Invited	2019-08-26 14:09:38	info@smgequipment.com	Bid Answer
SMG Equipment LLC	WA	Self Invited	2019-08-26 14:09:57	info@smgequipment.com	Bid Answer
SMG Equipment LLC	WA	Self Invited	2019-08-26 14:10:20	info@smgequipment.com	Bid Answer
SMG Equipment LLC	WA	Self Invited	2019-08-30 15:34:30	info@smgequipment.com	Bid Answer
SMG Equipment LLC	WA	Self Invited	2019-09-10 09:57:05	info@smgequipment.com	Addendum Notification
SMG Equipment LLC	WA	Self Invited	2019-09-13 12:50:00	info@smgequipment.com	Addendum Notification
SMG Equipment LLC	WA	Self Invited	2019-09-13 13:49:30	info@smgequipment.com	Bid Answer
Trius Inc.	NJ	Classification	2019-08-13 10:25:26	laltamura@triusonline.com	Bid Notification
Trius Inc.	NJ	Classification	2019-08-15 13:22:12	laltamura@triusonline.com	Addendum Notification
Trius Inc.	NJ	Classification	2019-08-21 08:44:43	laltamura@triusonline.com	Bid Answer
Trius Inc.	NJ	Classification	2019-08-26 14:08:46	laltamura@triusonline.com	Bid Answer
Trius Inc.	NJ	Classification	2019-08-26 14:09:15	laltamura@triusonline.com	Bid Answer
Trius Inc.	NJ	Classification	2019-08-26 14:09:38	laltamura@triusonline.com	Bid Answer
Trius Inc.	NJ	Classification	2019-08-26 14:09:57	laltamura@triusonline.com	Bid Answer
Trius Inc.	NJ	Classification	2019-08-26 14:10:20	laltamura@triusonline.com	Bid Answer
Trius Inc.	NJ	Classification	2019-08-30 15:34:30	laltamura@triusonline.com	Bid Answer
Trius Inc.	NJ	Classification	2019-09-10 09:57:05	laltamura@triusonline.com	Addendum Notification
Trius Inc.	NJ	Classification	2019-09-13 12:50:00	laltamura@triusonline.com	Addendum Notification
Trius Inc.	NJ	Classification	2019-09-13 13:49:31	laltamura@triusonline.com	Bid Answer
Venture Products, Inc	OH	Self Invited	2019-09-10 09:57:05	contracts@ventrac.com	Addendum Notification
Venture Products, Inc	OH	Self Invited	2019-09-13 12:50:00	contracts@ventrac.com	Addendum Notification
Venture Products, Inc	OH	Self Invited	2019-09-13 13:49:31	contracts@ventrac.com	Bid Answer
Weingartz	MI	Classification	2019-08-16 08:27:03	cbolton@weingartz.com	Bid Notification
Weingartz	MI	Classification	2019-08-21 08:44:43	cbolton@weingartz.com	Bid Answer
Weingartz	MI	Classification	2019-08-26 14:08:46	cbolton@weingartz.com	Bid Answer
Weingartz	MI	Classification	2019-08-26 14:09:15	cbolton@weingartz.com	Bid Answer
Weingartz	MI	Classification	2019-08-26 14:09:38	cbolton@weingartz.com	Bid Answer
Weingartz	MI	Classification	2019-08-26 14:09:57	cbolton@weingartz.com	Bid Answer
Weingartz	MI	Classification	2019-08-26 14:10:20	cbolton@weingartz.com	Bid Answer
Weingartz	MI	Classification	2019-08-30 15:34:30	cbolton@weingartz.com	Bid Answer
Weingartz	MI	Classification	2019-09-10 09:57:05	cbolton@weingartz.com	Addendum Notification
Weingartz	MI	Classification	2019-09-13 12:50:00	cbolton@weingartz.com	Addendum Notification
Weingartz	MI	Classification	2019-09-13 13:49:31	cbolton@weingartz.com	Bid Answer

Access Report

Agency
Bid Number
Bid Title

Association of Educational Purchasing Agencies
020-E
Lawn & Groundskeeping Equipment, Supplies & Services

Vendor Name	Accessed First Time	Most Recent Access	Documents	Most Recent Response Date
Westwind Landscape Construction, Inc.	2019-07-24 04:11 PM CDT	2019-07-24 04:11 PM CDT		
Lawson Products Inc	2019-07-31 01:46 PM CDT	2019-08-01 08:52 AM CDT	AEPA IFB #020-E Lawn Groundskeeping Equipment - Part F Discount Pricing Workbook - FINAL.xlsx AEPA Vendor Quarterly Report Template.pdf AEPA IFB #020-E Lawn Groundskeeping Equipment - Part E Signature Forms - FINAL.pdf AEPA IFB #020-E Lawn Groundskeeping Equipment - Part D Questionnaire - FINAL.docx AEPA IFB #020-E Lawn Groundskeeping Equipment - Part C Member Agency (State) Terms and Conditions - FINAL.pdf AEPA IFB #020-E Lawn Groundskeeping Equipment - Part B Specifications - FINAL.pdf AEPA IFB #020-E Lawn Groundskeeping Equipment - Part A Terms and Conditions - FINAL.pdf	
Deere & Company	2019-07-23 08:26 AM CDT	2019-09-13 01:56 PM CDT	AEPA IFB #020-E Lawn Groundskeeping Equipment - Part C Member Agency (State) Terms and Conditions - Amended 8.14.19.pdf AEPA IFB #020-E Lawn Groundskeeping Equipment - Part D Questionnaire - FINAL.docx AEPA IFB #020-E Lawn Groundskeeping Equipment - Part E Signature Forms - FINAL.pdf AEPA IFB #020-E Lawn Groundskeeping Equipment - Part C Member Agency (State) Terms and Conditions - FINAL.pdf AEPA IFB #020-E Lawn Groundskeeping Equipment - Part A Terms and Conditions - FINAL.pdf AEPA Vendor Quarterly Report Template.pdf AEPA IFB #020-E Lawn Groundskeeping Equipment - Part F Discount Pricing Workbook - FINAL.xlsx AEPA IFB #020-E Lawn Groundskeeping Equipment - Part B Specifications - FINAL.pdf	
Gambrills Equipment Company Inc	2019-08-15 09:48 AM CDT	2019-09-13 03:46 PM CDT	AEPA IFB #020-E Lawn Groundskeeping Equipment - Part F Discount Pricing Workbook - FINAL.xlsx AEPA IFB #020-E Lawn Groundskeeping Equipment - Part E Signature Forms - FINAL.pdf AEPA IFB #020-E Lawn Groundskeeping Equipment - Part D Questionnaire - FINAL.docx AEPA IFB #020-E Lawn Groundskeeping Equipment - Part C Member Agency (State) Terms and Conditions - FINAL.pdf AEPA IFB #020-E Lawn Groundskeeping Equipment - Part B Specifications - FINAL.pdf AEPA IFB #020-E Lawn Groundskeeping Equipment - Part A Terms and Conditions - FINAL.pdf	
AEPA PAEC	2019-08-21 02:19 PM CDT	2019-08-21 02:24 PM CDT	AEPA IFB #020-E Lawn Groundskeeping Equipment - Part C Member Agency (State) Terms and Conditions - Amended 8.14.19.pdf	
Hustler Turf Equipment	2019-08-26 04:52 PM CDT	2019-09-03 10:39 AM CDT	AEPA IFB #020-E Lawn Groundskeeping Equipment - Part E Signature Forms - FINAL.pdf AEPA IFB #020-E Lawn Groundskeeping Equipment - Part D Questionnaire - FINAL.docx AEPA IFB #020-E Lawn Groundskeeping Equipment - Part B Specifications - FINAL.pdf 020-E Lawn & Groundskeeping Equipment, Supplies & Services.m4a AEPA IFB #020-E Lawn Groundskeeping Equipment - Part A Terms and Conditions - FINAL.pdf	

Allied Construction Industries	2019-08-05 12:46 PM CDT	2019-09-17 09:13 AM CDT	<p>AEPA IFB #020-E Lawn Groundskeeping Equipment - Part C Member Agency (State) Terms and Conditions - Amended 9.10.19.pdf</p> <p>020-E Lawn & Groundskeeping Equipment, Supplies & Services.m4a</p> <p>AEPA IFB #020-E Lawn Groundskeeping Equipment - Part C Member Agency (State) Terms and Conditions - Amended 8.14.19.pdf</p> <p>AEPA IFB #020-E Lawn Groundskeeping Equipment - Part F Discount Pricing Workbook - FINAL.xlsx</p> <p>AEPA IFB #020-E Lawn Groundskeeping Equipment - Part E Signature Forms - FINAL.pdf</p> <p>AEPA IFB #020-E Lawn Groundskeeping Equipment - Part D Questionnaire - FINAL.docx</p> <p>AEPA IFB #020-E Lawn Groundskeeping Equipment - Part C Member Agency (State) Terms and Conditions - FINAL.pdf</p> <p>AEPA IFB #020-E Lawn Groundskeeping Equipment - Part B Specifications - FINAL.pdf</p> <p>AEPA IFB #020-E Lawn Groundskeeping Equipment - Part A Terms and Conditions - FINAL.pdf</p>
Weingartz	2019-08-16 09:53 AM CDT	2019-09-05 10:11 AM CDT	<p>AEPA IFB #020-E Lawn Groundskeeping Equipment - Part F Discount Pricing Workbook - FINAL.xlsx</p> <p>AEPA IFB #020-E Lawn Groundskeeping Equipment - Part D Questionnaire - FINAL.docx</p> <p>020-E Lawn & Groundskeeping Equipment, Supplies & Services.m4a</p> <p>AEPA Vendor Quarterly Report Template.pdf</p> <p>AEPA IFB #020-E Lawn Groundskeeping Equipment - Part E Signature Forms - FINAL.pdf</p> <p>AEPA IFB #020-E Lawn Groundskeeping Equipment - Part C Member Agency (State) Terms and Conditions - Amended 8.14.19.pdf</p> <p>AEPA IFB #020-E Lawn Groundskeeping Equipment - Part B Specifications - FINAL.pdf</p> <p>AEPA IFB #020-E Lawn Groundskeeping Equipment - Part A Terms and Conditions - FINAL.pdf</p>
Marion Ford Tractor, Inc.	2019-08-02 02:42 PM CDT	2019-08-02 02:49 PM CDT	<p>AEPA Vendor Quarterly Report Template.pdf</p> <p>AEPA IFB #020-E Lawn Groundskeeping Equipment - Part F Discount Pricing Workbook - FINAL.xlsx</p> <p>AEPA IFB #020-E Lawn Groundskeeping Equipment - Part E Signature Forms - FINAL.pdf</p> <p>AEPA IFB #020-E Lawn Groundskeeping Equipment - Part D Questionnaire - FINAL.docx</p> <p>AEPA IFB #020-E Lawn Groundskeeping Equipment - Part C Member Agency (State) Terms and Conditions - FINAL.pdf</p> <p>AEPA IFB #020-E Lawn Groundskeeping Equipment - Part B Specifications - FINAL.pdf</p> <p>AEPA IFB #020-E Lawn Groundskeeping Equipment - Part A Terms and Conditions - FINAL.pdf</p>
Deere & Company	2019-09-05 09:59 AM CDT	2019-09-06 10:31 AM CDT	<p>020-E Lawn & Groundskeeping Equipment, Supplies & Services.m4a</p> <p>AEPA IFB #020-E Lawn Groundskeeping Equipment - Part F Discount Pricing Workbook - FINAL.xlsx</p> <p>AEPA IFB #020-E Lawn Groundskeeping Equipment - Part C Member Agency (State) Terms and Conditions - Amended 8.14.19.pdf</p> <p>AEPA Vendor Quarterly Report Template.pdf</p> <p>AEPA IFB #020-E Lawn Groundskeeping Equipment - Part E Signature Forms - FINAL.pdf</p> <p>AEPA IFB #020-E Lawn Groundskeeping Equipment - Part D Questionnaire - FINAL.docx</p> <p>AEPA IFB #020-E Lawn Groundskeeping Equipment - Part B Specifications - FINAL.pdf</p> <p>AEPA IFB #020-E Lawn Groundskeeping Equipment - Part A Terms and Conditions - FINAL.pdf</p>
Monroe Tractor	2019-07-25 09:16 AM CDT	2019-08-21 11:22 AM CDT	<p>AEPA IFB #020-E Lawn Groundskeeping Equipment - Part F Discount Pricing Workbook - FINAL.xlsx</p>

Moridge Manufacturing Inc.	2019-07-23 12:51 PM CDT	2019-09-16 02:57 PM CDT	020-E Lawn & Groundskeeping Equipment, Supplies & Services.m4a AEPA IFB #020-E Lawn Groundskeeping Equipment - Part C Member Agency (State) Terms and Conditions - Amended 8.14.19.pdf AEPA IFB #020-E Lawn Groundskeeping Equipment - Part F Discount Pricing Workbook - FINAL.xlsx AEPA Vendor Quarterly Report Template.pdf AEPA IFB #020-E Lawn Groundskeeping Equipment - Part E Signature Forms - FINAL.pdf AEPA IFB #020-E Lawn Groundskeeping Equipment - Part D Questionnaire - FINAL.docx AEPA IFB #020-E Lawn Groundskeeping Equipment - Part C Member Agency (State) Terms and Conditions - FINAL.pdf AEPA IFB #020-E Lawn Groundskeeping Equipment - Part B Specifications - FINAL.pdf AEPA IFB #020-E Lawn Groundskeeping Equipment - Part A Terms and Conditions - FINAL.pdf	
Husqvarna Professional Products, Inc.	2019-07-25 10:27 AM CDT	2019-09-23 12:09 PM CDT	AEPA IFB #020-E Lawn Groundskeeping Equipment - Part C Member Agency (State) Terms and Conditions - Amended 9.13.19.pdf AEPA Vendor Quarterly Report Template.pdf AEPA IFB #020-E Lawn Groundskeeping Equipment - Part C Member Agency (State) Terms and Conditions - Amended 9.10.19.pdf AEPA IFB #020-E Lawn Groundskeeping Equipment - Part E Signature Forms - FINAL.pdf AEPA IFB #020-E Lawn Groundskeeping Equipment - Part D Questionnaire - FINAL.docx AEPA IFB #020-E Lawn Groundskeeping Equipment - Part C Member Agency (State) Terms and Conditions - Amended 8.14.19.pdf 020-E Lawn & Groundskeeping Equipment, Supplies & Services.m4a AEPA IFB #020-E Lawn Groundskeeping Equipment - Part A Terms and Conditions - FINAL.pdf AEPA IFB #020-E Lawn Groundskeeping Equipment - Part F Discount Pricing Workbook - FINAL.xlsx AEPA IFB #020-E Lawn Groundskeeping Equipment - Part B Specifications - FINAL.pdf	2019-09-16 10:26 AM CDT
Controlled Products	2019-08-15 09:49 AM CDT	2019-08-15 09:49 AM CDT		
The Education Cooperative	2019-08-08 08:04 AM CDT	2019-08-08 08:07 AM CDT		
SmartProcure	2019-07-22 09:00 PM CDT	2019-09-13 04:54 PM CDT	AEPA IFB #020-E Lawn Groundskeeping Equipment - Part C Member Agency (State) Terms and Conditions - Amended 9.13.19.pdf AEPA IFB #020-E Lawn Groundskeeping Equipment - Part C Member Agency (State) Terms and Conditions - Amended 9.10.19.pdf 020-E Lawn & Groundskeeping Equipment, Supplies & Services.m4a AEPA IFB #020-E Lawn Groundskeeping Equipment - Part C Member Agency (State) Terms and Conditions - Amended 8.14.19.pdf AEPA Vendor Quarterly Report Template.pdf AEPA IFB #020-E Lawn Groundskeeping Equipment - Part E Signature Forms - FINAL.pdf AEPA IFB #020-E Lawn Groundskeeping Equipment - Part D Questionnaire - FINAL.docx AEPA IFB #020-E Lawn Groundskeeping Equipment - Part C Member Agency (State) Terms and Conditions - FINAL.pdf AEPA IFB #020-E Lawn Groundskeeping Equipment - Part B Specifications - FINAL.pdf AEPA IFB #020-E Lawn Groundskeeping Equipment - Part A Terms and Conditions - FINAL.pdf AEPA IFB #020-E Lawn Groundskeeping Equipment - Part F Discount Pricing Workbook - FINAL.xlsx	

bobcat company	2019-08-01 08:31 AM CDT	2019-09-12 10:04 PM CDT	<p>AEPA IFB #020-E Lawn Groundskeeping Equipment - Part C Member Agency (State) Terms and Conditions - Amended 9.10.19.pdf</p> <p>020-E Lawn & Groundskeeping Equipment, Supplies & Services.m4a</p> <p>AEPA IFB #020-E Lawn Groundskeeping Equipment - Part C Member Agency (State) Terms and Conditions - Amended 8.14.19.pdf</p> <p>AEPA Vendor Quarterly Report Template.pdf</p> <p>AEPA IFB #020-E Lawn Groundskeeping Equipment - Part F Discount Pricing Workbook - FINAL.xlsx</p> <p>AEPA IFB #020-E Lawn Groundskeeping Equipment - Part E Signature Forms - FINAL.pdf</p> <p>AEPA IFB #020-E Lawn Groundskeeping Equipment - Part C Member Agency (State) Terms and Conditions - FINAL.pdf</p> <p>AEPA IFB #020-E Lawn Groundskeeping Equipment - Part A Terms and Conditions - FINAL.pdf</p> <p>AEPA IFB #020-E Lawn Groundskeeping Equipment - Part D Questionnaire - FINAL.docx</p> <p>AEPA IFB #020-E Lawn Groundskeeping Equipment - Part B Specifications - FINAL.pdf</p>	2019-09-12 10:03 PM CDT
Dodge Data & Analytics	2019-07-23 11:48 AM CDT	2019-10-09 07:00 AM CDT	<p>AEPA IFB #020-E Lawn Groundskeeping Equipment - Part C Member Agency (State) Terms and Conditions - Amended 9.13.19.pdf</p> <p>AEPA IFB #020-E Lawn Groundskeeping Equipment - Part C Member Agency (State) Terms and Conditions - Amended 9.10.19.pdf</p> <p>020-E Lawn & Groundskeeping Equipment, Supplies & Services.m4a</p> <p>AEPA IFB #020-E Lawn Groundskeeping Equipment - Part C Member Agency (State) Terms and Conditions - Amended 8.14.19.pdf</p> <p>AEPA Vendor Quarterly Report Template.pdf</p> <p>AEPA IFB #020-E Lawn Groundskeeping Equipment - Part F Discount Pricing Workbook - FINAL.pdf</p> <p>AEPA IFB #020-E Lawn Groundskeeping Equipment - Part E Signature Forms - FINAL.pdf</p> <p>AEPA IFB #020-E Lawn Groundskeeping Equipment - Part D Questionnaire - FINAL.pdf</p> <p>AEPA IFB #020-E Lawn Groundskeeping Equipment - Part C Member Agency (State) Terms and Conditions - FINAL.pdf</p> <p>AEPA IFB #020-E Lawn Groundskeeping Equipment - Part B Specifications - FINAL.pdf</p> <p>AEPA IFB #020-E Lawn Groundskeeping Equipment - Part A Terms and Conditions - FINAL.pdf</p>	
RICHARD RAAB	2019-08-07 08:19 AM CDT	2019-08-07 08:19 AM CDT		
SMG Equipment LLC	2019-08-19 12:28 PM CDT	2019-09-16 11:22 AM CDT	<p>AEPA IFB #020-E Lawn Groundskeeping Equipment - Part C Member Agency (State) Terms and Conditions - Amended 9.13.19.pdf</p> <p>AEPA IFB #020-E Lawn Groundskeeping Equipment - Part C Member Agency (State) Terms and Conditions - Amended 8.14.19.pdf</p> <p>AEPA Vendor Quarterly Report Template.pdf</p> <p>AEPA IFB #020-E Lawn Groundskeeping Equipment - Part F Discount Pricing Workbook - FINAL.xlsx</p> <p>AEPA IFB #020-E Lawn Groundskeeping Equipment - Part E Signature Forms - FINAL.pdf</p> <p>AEPA IFB #020-E Lawn Groundskeeping Equipment - Part D Questionnaire - FINAL.docx</p> <p>AEPA IFB #020-E Lawn Groundskeeping Equipment - Part A Terms and Conditions - FINAL.pdf</p> <p>AEPA IFB #020-E Lawn Groundskeeping Equipment - Part B Specifications - FINAL.pdf</p>	2019-09-16 11:20 AM CDT
Sema Equipment	2019-08-22 03:30 PM CDT	2019-08-22 03:30 PM CDT		

SafetyFirst Playground Surfacing, LLC	2019-08-20 02:10 PM CDT	2019-09-13 04:04 PM CDT	020-E Lawn & Groundskeeping Equipment, Supplies & Services.m4a AEPA IFB #020-E Lawn Groundskeeping Equipment - Part C Member Agency (State) Terms and Conditions - Amended 8.14.19.pdf AEPA Vendor Quarterly Report Template.pdf AEPA IFB #020-E Lawn Groundskeeping Equipment - Part D Questionnaire - FINAL.docx AEPA IFB #020-E Lawn Groundskeeping Equipment - Part E Signature Forms - FINAL.pdf AEPA IFB #020-E Lawn Groundskeeping Equipment - Part F Discount Pricing Workbook - FINAL.xlsx AEPA IFB #020-E Lawn Groundskeeping Equipment - Part A Terms and Conditions - FINAL.pdf AEPA IFB #020-E Lawn Groundskeeping Equipment - Part B Specifications - FINAL.pdf	
Pathfinder Tree Service, LLC	2019-08-08 02:16 PM CDT	2019-09-10 11:38 AM CDT	020-E Lawn & Groundskeeping Equipment, Supplies & Services.m4a AEPA IFB #020-E Lawn Groundskeeping Equipment - Part C Member Agency (State) Terms and Conditions - Amended 9.10.19.pdf AEPA IFB #020-E Lawn Groundskeeping Equipment - Part C Member Agency (State) Terms and Conditions - Amended 8.14.19.pdf AEPA Vendor Quarterly Report Template.pdf AEPA IFB #020-E Lawn Groundskeeping Equipment - Part F Discount Pricing Workbook - FINAL.xlsx AEPA IFB #020-E Lawn Groundskeeping Equipment - Part E Signature Forms - FINAL.pdf AEPA IFB #020-E Lawn Groundskeeping Equipment - Part D Questionnaire - FINAL.docx AEPA IFB #020-E Lawn Groundskeeping Equipment - Part C Member Agency (State) Terms and Conditions - FINAL.pdf AEPA IFB #020-E Lawn Groundskeeping Equipment - Part B Specifications - FINAL.pdf AEPA IFB #020-E Lawn Groundskeeping Equipment - Part A Terms and Conditions - FINAL.pdf	
SafetyFirst Playground Surfacing LLC	2019-07-29 04:52 PM CDT	2019-07-29 05:00 PM CDT	AEPA IFB #020-E Lawn Groundskeeping Equipment - Part F Discount Pricing Workbook - FINAL.xlsx AEPA IFB #020-E Lawn Groundskeeping Equipment - Part D Questionnaire - FINAL.docx AEPA IFB #020-E Lawn Groundskeeping Equipment - Part C Member Agency (State) Terms and Conditions - FINAL.pdf AEPA IFB #020-E Lawn Groundskeeping Equipment - Part B Specifications - FINAL.pdf	
Builders Exchange	2019-09-06 02:13 PM CDT	2019-09-06 02:13 PM CDT		
Venture Products, Inc	2019-09-03 03:44 PM CDT	2019-09-13 01:59 PM CDT	AEPA IFB #020-E Lawn Groundskeeping Equipment - Part D Questionnaire - FINAL.docx AEPA IFB #020-E Lawn Groundskeeping Equipment - Part A Terms and Conditions - FINAL.pdf AEPA IFB #020-E Lawn Groundskeeping Equipment - Part C Member Agency (State) Terms and Conditions - Amended 9.10.19.pdf 020-E Lawn & Groundskeeping Equipment, Supplies & Services.m4a AEPA Vendor Quarterly Report Template.pdf AEPA IFB #020-E Lawn Groundskeeping Equipment - Part F Discount Pricing Workbook - FINAL.xlsx AEPA IFB #020-E Lawn Groundskeeping Equipment - Part E Signature Forms - FINAL.pdf AEPA IFB #020-E Lawn Groundskeeping Equipment - Part B Specifications - FINAL.pdf	
Onvia	2019-07-29 02:10 PM CDT	2019-09-16 01:22 AM CDT	AEPA Vendor Quarterly Report Template.pdf AEPA IFB #020-E Lawn Groundskeeping Equipment - Part F Discount Pricing Workbook - FINAL.pdf AEPA IFB #020-E Lawn Groundskeeping Equipment - Part E Signature Forms - FINAL.pdf AEPA IFB #020-E Lawn Groundskeeping Equipment - Part D Questionnaire - FINAL.pdf AEPA IFB #020-E Lawn Groundskeeping Equipment - Part C Member Agency (State) Terms and Conditions - FINAL.pdf AEPA IFB #020-E Lawn Groundskeeping Equipment - Part B Specifications - FINAL.pdf	

SARLO POWER MOWERS, INC.	2019-09-16 11:58 AM CDT	2019-09-16 12:10 PM CDT	AEPA IFB #020-E Lawn Groundskeeping Equipment - Part C Member Agency (State) Terms and Conditions - Amended 9.13.19.pdf 020-E Lawn & Groundskeeping Equipment, Supplies & Services.m4a AEPA Vendor Quarterly Report Template.pdf AEPA IFB #020-E Lawn Groundskeeping Equipment - Part E Signature Forms - FINAL.pdf AEPA IFB #020-E Lawn Groundskeeping Equipment - Part B Specifications - FINAL.pdf AEPA IFB #020-E Lawn Groundskeeping Equipment - Part F Discount Pricing Workbook - FINAL.xlsx AEPA IFB #020-E Lawn Groundskeeping Equipment - Part D Questionnaire - FINAL.docx AEPA IFB #020-E Lawn Groundskeeping Equipment - Part A Terms and Conditions - FINAL.pdf	
L&L Supplies	2019-08-22 03:10 PM CDT	2019-08-22 03:11 PM CDT	020-E Lawn & Groundskeeping Equipment, Supplies & Services.m4a AEPA IFB #020-E Lawn Groundskeeping Equipment - Part C Member Agency (State) Terms and Conditions - Amended 8.14.19.pdf AEPA Vendor Quarterly Report Template.pdf AEPA IFB #020-E Lawn Groundskeeping Equipment - Part F Discount Pricing Workbook - FINAL.xlsx AEPA IFB #020-E Lawn Groundskeeping Equipment - Part E Signature Forms - FINAL.pdf AEPA IFB #020-E Lawn Groundskeeping Equipment - Part D Questionnaire - FINAL.docx AEPA IFB #020-E Lawn Groundskeeping Equipment - Part B Specifications - FINAL.pdf AEPA IFB #020-E Lawn Groundskeeping Equipment - Part A Terms and Conditions - FINAL.pdf	
Makita U.S.A., Inc.	2019-07-31 12:47 PM CDT	2019-09-16 11:59 AM CDT	AEPA IFB #020-E Lawn Groundskeeping Equipment - Part C Member Agency (State) Terms and Conditions - Amended 9.13.19.pdf 020-E Lawn & Groundskeeping Equipment, Supplies & Services.m4a AEPA IFB #020-E Lawn Groundskeeping Equipment - Part C Member Agency (State) Terms and Conditions - Amended 8.14.19.pdf AEPA Vendor Quarterly Report Template.pdf AEPA IFB #020-E Lawn Groundskeeping Equipment - Part F Discount Pricing Workbook - FINAL.xlsx AEPA IFB #020-E Lawn Groundskeeping Equipment - Part E Signature Forms - FINAL.pdf AEPA IFB #020-E Lawn Groundskeeping Equipment - Part D Questionnaire - FINAL.docx AEPA IFB #020-E Lawn Groundskeeping Equipment - Part C Member Agency (State) Terms and Conditions - FINAL.pdf AEPA IFB #020-E Lawn Groundskeeping Equipment - Part B Specifications - FINAL.pdf AEPA IFB #020-E Lawn Groundskeeping Equipment - Part A Terms and Conditions - FINAL.pdf	
Mick Rich Contractors, Inc	2019-08-14 10:13 AM CDT	2019-08-19 07:52 AM CDT	020-E Lawn & Groundskeeping Equipment, Supplies & Services.m4a AEPA IFB #020-E Lawn Groundskeeping Equipment - Part C Member Agency (State) Terms and Conditions - Amended 8.14.19.pdf AEPA Vendor Quarterly Report Template.pdf AEPA IFB #020-E Lawn Groundskeeping Equipment - Part E Signature Forms - FINAL.pdf AEPA IFB #020-E Lawn Groundskeeping Equipment - Part B Specifications - FINAL.pdf AEPA IFB #020-E Lawn Groundskeeping Equipment - Part A Terms and Conditions - FINAL.pdf AEPA IFB #020-E Lawn Groundskeeping Equipment - Part D Questionnaire - FINAL.docx AEPA IFB #020-E Lawn Groundskeeping Equipment - Part F Discount Pricing Workbook - FINAL.xlsx	
Altoz	2019-08-12 10:24 AM CDT	2019-08-12 10:24 AM CDT		
School Wholesale Supplies LLC	2019-07-24 03:14 AM CDT	2019-07-24 03:14 AM CDT		
The Education Cooperative	2019-08-08 01:26 PM CDT	2019-08-08 01:26 PM CDT		

Trius Inc.	2019-08-13 10:15 AM CDT	2019-09-13 03:23 PM CDT	<p>AEPA IFB #020-E Lawn Groundskeeping Equipment - Part C Member Agency (State) Terms and Conditions - Amended 9.13.19.pdf</p> <p>AEPA IFB #020-E Lawn Groundskeeping Equipment - Part C Member Agency (State) Terms and Conditions - Amended 9.10.19.pdf</p> <p>020-E Lawn & Groundskeeping Equipment, Supplies & Services.m4a</p> <p>AEPA IFB #020-E Lawn Groundskeeping Equipment - Part C Member Agency (State) Terms and Conditions - Amended 8.14.19.pdf</p> <p>AEPA Vendor Quarterly Report Template.pdf</p> <p>AEPA IFB #020-E Lawn Groundskeeping Equipment - Part F Discount Pricing Workbook - FINAL.xlsx</p> <p>AEPA IFB #020-E Lawn Groundskeeping Equipment - Part E Signature Forms - FINAL.pdf</p> <p>AEPA IFB #020-E Lawn Groundskeeping Equipment - Part D Questionnaire - FINAL.docx</p> <p>AEPA IFB #020-E Lawn Groundskeeping Equipment - Part C Member Agency (State) Terms and Conditions - FINAL.pdf</p> <p>AEPA IFB #020-E Lawn Groundskeeping Equipment - Part B Specifications - FINAL.pdf</p> <p>AEPA IFB #020-E Lawn Groundskeeping Equipment - Part A Terms and Conditions - FINAL.pdf</p>
ACS Landscape Management	2019-07-31 01:45 PM CDT	2019-07-31 01:46 PM CDT	<p>AEPA IFB #020-E Lawn Groundskeeping Equipment - Part B Specifications - FINAL.pdf</p> <p>AEPA IFB #020-E Lawn Groundskeeping Equipment - Part A Terms and Conditions - FINAL.pdf</p>
John Tortelli	2019-07-22 03:34 PM CDT	2019-08-19 09:49 AM CDT	<p>AEPA IFB #020-E Lawn Groundskeeping Equipment - Part C Member Agency (State) Terms and Conditions - Amended 8.14.19.pdf</p> <p>AEPA IFB #020-E Lawn Groundskeeping Equipment - Part B Specifications - FINAL.pdf</p> <p>AEPA Vendor Quarterly Report Template.pdf</p> <p>AEPA IFB #020-E Lawn Groundskeeping Equipment - Part F Discount Pricing Workbook - FINAL.xlsx</p> <p>AEPA IFB #020-E Lawn Groundskeeping Equipment - Part E Signature Forms - FINAL.pdf</p> <p>AEPA IFB #020-E Lawn Groundskeeping Equipment - Part D Questionnaire - FINAL.docx</p> <p>AEPA IFB #020-E Lawn Groundskeeping Equipment - Part C Member Agency (State) Terms and Conditions - FINAL.pdf</p> <p>AEPA IFB #020-E Lawn Groundskeeping Equipment - Part A Terms and Conditions - FINAL.pdf</p>
Epylon Corporation	2019-08-20 04:56 PM CDT	2019-08-20 05:07 PM CDT	
North America Procurement Council	2019-07-23 12:29 AM CDT	2019-09-18 01:25 AM CDT	<p>AEPA IFB #020-E Lawn Groundskeeping Equipment - Part C Member Agency (State) Terms and Conditions - Amended 9.13.19.pdf</p> <p>AEPA IFB #020-E Lawn Groundskeeping Equipment - Part C Member Agency (State) Terms and Conditions - Amended 9.10.19.pdf</p> <p>020-E Lawn & Groundskeeping Equipment, Supplies & Services.m4a</p> <p>AEPA IFB #020-E Lawn Groundskeeping Equipment - Part C Member Agency (State) Terms and Conditions - Amended 8.14.19.pdf</p> <p>AEPA IFB #020-E Lawn Groundskeeping Equipment - Part B Specifications - FINAL.pdf</p>
CliftonLarsonAllen LLP	2019-08-23 07:58 AM CDT	2019-08-23 07:58 AM CDT	

AEPA 020 - Bid Opening

Responding Company Names	Bid Security	Require Signature Forms	Part D - Questionnaire	Part F - Pricing Workbook	Letter of Credit/Annual Report	Warranties, Additional Services (Optional)	Additional Discounts (Optional)	Other (Optional)	Send to Bid Committee
	Complete: Y or N	Signatures/Notary required	Complete: Y or N	Complete: Y or N	Complete: Y or N	Y or N	Y or N	Y or N	Y or N
020-A Athletic Surfaces - Natural & Synthetic Surfaces for Sports Fields, Tracks, Courts, Playground & Landscaping Applications									
ACT Global Americas, Inc 4201 West Parmer Lane, Austin, TX 78727	Y	Y	Y	Y	Y	Y	Y	Y	Yes
AstroTurf Corporation 2680 Abutment Road Dalton, GA 30721	Y	Y	Y	Y	Y	Y	Y	Y	Yes
SportSurfaces Distributing, Inc 1311 Cuesta Abajo Ct NE, Ste B Albuquerque, NM 87113	Y	Y	Y	Y	Y	Y	Y	Y	Yes
Dynamic Sports Construction, Inc. 301 Sonny Dr. Leander, TX 78641	Y	Y	Y	Y	N	Y	Y	Y	No
FieldTurf USA, Inc. 175 N. Industrial Blvd NE, Calhoun, GA 30701	Y	Y	Y	Y	Y	Y	Y	Y	Yes
Hellas Construction, Inc. 12710 Research Blvd, Ste. 240, Austin, TX 78759	Y	Y	Y	Y	Y	Y	Y	Y	Yes
The Motz Group 3607 Church St. Cincinnati, OH 45244	Y	Y	Y	Y	Y	Y	Y	Y	Yes
Mathusek, Inc. 258 Iron Horse Rd, Oakland, NJ 07436	Y	Y	Y	Y	Y	Y	Y	Y	Yes
Shaw Sports Turf, Inc 185 South Industrial Blvd. Calhoun, GA 30701	Y	Y	Y	Y	Y	Y	Y	Y	Yes
Vescio's SportsFields, Inc. 901 Old Todds Road, Lexington, KY 40509	Y	Y	Y	Y	Y	Y	Y	Y	Yes
Sprinturf, LLC. 146 Fairchild St., Suite 150, Daniel Island, SC 29492	Y	Y	Y	Y	Y	Y	Y	Y	Yes
SMG Equipment, LLC. 2002 West Valley Hwy N., Ste. 200 Auburn, WA 98001	N								No
020-B Carpet & Resilient Flooring									
Interface Americas, Inc. 1503 Orchard Hill Rd, LaGrange, GA 30240	N/A	Y	Y	Y	Y	Y	Y	Y	Yes
Gillespie Group, Inc. 5 Chris Court, Suite G, Dayton, NJ 08810	N/A	Y	Y	Y	Y	Y	Y	Y	Yes
Mathusek, Inc. 258 Iron Horse Rd, Oakland, NJ 07436	N/A	Y	Y	N	Y	Y	Y	Y	No
020-C Digital Resources & Instructional Materials									
Bio Corporation 3910 Minnesota St. Alexandria, MN 56308	N/A	Y	Y	Y	Y	Y	Y	Y	Yes
Complete Book and Media Supply, Co. 1200 Toro Grande Dr, Suite 200, Cedar Park, TX 78613	N/A	Y	Y	Y	Y	Y	Y	Y	Yes
Imagination Station Inc. 8150 N. Central Expressway, Suite 2000 Dallas, TX 75206	N/A	Y	Y	Y	Y	Y	Y	Y	Yes
Learn Platform, Inc. 517 W. North St. Raleigh, NC 27603	N/A	Y	Y	Y	N	Y	Y	Y	No
Mackin Educational Resources 3505 County Road 42 W. Burnsville, MN 55306	N/A	Y	Y	Y	Y	Y	Y	Y	Yes
Newsela 620 8th Ave New York, NY 10018	N/A	Y	Y	Y	Y	Y	Y	Y	No
Saddleback Educational, Inc. 151 Kalimus Dr., Suite J-1 Costa Mesa, CA 92626	N/A	Y	Y	Y	Y	Y	Y	Y	Yes

020-D Facility Management Software

AkitaBox Inc. 212 E. Washington Ave., Floor Madison, WI 53703	N/A	Y	Y	Y	Y	Y	Y	Y	Y	Yes
Archibus, Inc. 18 Trammont St. Boston, MA 02108	N/A	Y	Y	Y	N	Y	Y	Y	Y	No
Dude Solutions, Inc. 11000 Regency Parkway, Suite 110 Cary, NC 27518	N/A	Y	Y	Y	Y	Y	Y	Y	Y	Yes

020-E Lawn & Groundskeeping Equipment, Supplies & Services

Bobcat Company 250 East Beaton Dr. West Fargo, ND 58078	N/A	Y	Y	Y	Y	Y	Y	Y	Y	Yes
SMG Equipment, LLC 2002 West Valley Hwy N., Ste. 200 Auburn, WA 98001	N/A	Y	Y	Y	Y	Y	Y	Y	Y	Yes
Husqvarna Professional Products Inc. 9335 Harris Corners Parkway, Suite 500 Charlotte, NC 28269	N/A	Y	Y	Y	Y	Y	Y	Y	Y	Yes

020-F Digital Display Solutions

Daktronics, Inc. 201 Daktronics Drive Brookings, SD 57006	N/A	Y	Y	Y	Y	Y	Y	Y	Y	Yes
Imperatives, Inc. 2818 Curry Rd. Schenectady, NY 12303	N/A	Y	Y	Y	Y	Y	Y	Y	Y	Yes

Opening Date:		16-Sep-19								
Opening Time:										1:30 PM EST

Exec. Bid Committee Chair:	Jane Eastes, Bid Chair	Witnesses:	Lisa Truax, MN	Andrew Pickens, TX
			Anna Marie Hollander, MI	Tina Smith, KS
			Ken Swink, OH	John Tortelli, NM
			George Wilson, Executive Director	Ken Swink, OH
			Craig Peterson, NE	
			Joni Puffett, IA	

Association of Educational Purchasing Agencies
Tabulation Report IFB #020-E - Lawn &
Groundskeeping Equipment, Supplies & Services
Vendor: bobcat company

General Comments:

General Attachments: 1 - Executive Coverpage - Bobcat Company.pdf
Exhibit A - Annual Report - Bobcat Company.pdf
Exhibit C - Machine Specifications - Bobcat Company.pdf
Exhibit C - Warranties - Bobcat Company.pdf
Part C - State Specific Forms - Bobcat Company.pdf
Part D - Questionnaire - Bobcat Company.pdf
Part E - Signature Forms - Bobcat Company.pdf
Part F - Pricing Schedule - Bobcat Company.xlsx
Price List - July 2019 - Bobcat Company.pdf

Annual Report on File with CPC/NDESC.



Association of Educational
PURCHASING AGENCIES

Part D - Questionnaire
AEPA IFB 020-E
Lawn & Groundskeeping Equipment, Supplies & Services

Instructions

This questionnaire contains forms and requests for information required by AEPA for vendor evaluation for responsiveness and responsibility.

To submit the required forms, follow these steps:

1. Read the documents in their entirety.
2. Bidders must use Part D – Questionnaire to its capacity. Attached exhibits and/or supplemental information should be included only when requested (i.e. Annual Report, Marketing Plan).
3. Complete all questions.
4. Save all pages in the correct order to a single PDF format titled “**Part D – Questionnaire – Name of Bidding Company**”.
5. Submit Part D, along with other required documents in Public Purchase.

The following sections will need to be completed prior to submission and submitted as one single PDF titled “Part D – Questionnaire – Name of Bidding Company”:

Company Information

Service Questionnaire

Exceptions

Deviations

Company Information

Name of Bidding Company: Clark Equipment Company dba Bobcat Company

Company Address: 250 East Beaton Drive

City, State Zip code: West Fargo, ND 58078

Website: Bobcat.com

Contact Person: Jesse Rheault

Title: Government Account Manager

Phone: 701-630-5134

Email: Jesse.Rheault@doosan.com

Background

Note: Generally, AEPA will not accept an offer from a business that is less than five (5) years old or, which fails to demonstrate and/or establish a proven record of business. If the bidder has recently purchased an established business or, has proof of prior success in either this business or a closely related business, provide written documentation and verification in response to the questions below. AEPA reserves the right to accept or reject newly formed companies based on information provided in this response and from its own investigation of the company.

Bobcat Company Background: The renowned Bobcat brand — ours since the name was first used in 1962 — is synonymous with durability and dependability. Tough, versatile, agile Bobcat® equipment — with its time-tested reliability — has rightly earned the nickname “One Tough Animal.” Bobcat Company continues to be committed to delivering the industry’s best compact equipment.



Bobcat Company has the most extensive compact equipment distribution network in the world. Some 1,000 independent Bobcat dealers back each and every piece of Bobcat equipment, serving customers thousands of local sales, service, parts and rental specialists. Bobcat dealers are known for their dedication to providing outstanding customer service to ensure long, reliable equipment performance.

This business is a: **public company** **privately owned company**

In what year was this business started under its present name? 1969

Under what additional, or, former name(s) has your business operated?

Is this business a corporation? **No** **Yes. If yes, complete the following:**

Date of Incorporation: 1969

State of Incorporation: Delaware

Name of President: Mike Ballweber

Name(s) of Vice President(s): Joel Honeyman, Steven Thompson
 Name of Treasurer: Eric Spilde - VP Finance
 Name of Secretary: Courtney Fletcher

Is this business a partnership? No Yes. If yes, complete the following:
 Date of Partnership: _____
 State Founded: _____
 Type of Partnership, if applicable: _____
 Name(s) of General Partner(s): _____

Is this business individually owned? No Yes. If yes, complete the following:
 Date of Purchase: _____
 State Founded: _____
 Name of Owner/Operator: _____

Is this business different from those identified above? No Yes
 If yes, describe the company's format, year and state of origin and names and titles of the principles below.

Is this business women owned? No Yes

Is this business minority owned? No Yes

Does this business have an Affirmative Action Plan/Statement? No Yes

Business Headquarter Location

Business Address 250 East Beaton Drive
 City, State Zip code West Fargo, ND 58078
 Phone 701-630-5134
 How long at this address? 10+ Years

Business Branch Location(s)



Sales History

Provide your business's annual sales for 2017, 2018, and 2019 YTD in the United States by the various public segments.

	2017	2018	2019 YTD
K-12 (public & private), Educational Service Agencies	\$10M	\$6.3M	\$5.7M
Higher Education Institutions	* Bobcat Company did differentiate educational institutions in 2017	5.7M	\$4.5M
Counties, Cities, Townships, Villages	\$65.5M	\$73M	\$50M
States	\$79k	\$8.5M	\$15M
Other Public Sector & Non-profits	\$24.5M	\$27M	\$13M
Private Sector	~\$2B	~\$2B	Unknown
Total	~\$2B	~\$2B	

Work Force

Key Contacts and Providers: Provide a list of the individuals, titles, and contact information for the individuals who will provide the following services on a national and/or local basis:

Function	Name	Title	Phone	Email
Contract Manager	Jesse Rheault	Government Account Manager	701-630-5134	Jesse.Rheault@Doosan.com
East Region Government Manager	Barry Hanson	Government Account Manager	701-241-8793	Barry.Hanson@Doosan.com
Director of Government Accounts	Randy Fuss	Director of Government Accounts	701-241-8746	Randy.Fuss@Doosan.com
Government Sales Support Manager	Heather Messmer	Government Sales Support Manager	701-241-8719	Heather.Messmer@Doosan.com

Sales Force: Provide total number and location of salespersons employed by your business in the United States by completing the following: *(To insert more rows, hit the tab key from the last field in the State column.)*

Number of Sales Reps	City	State
64 Dedicated Territory Sales Reps Across the Country Supporting the Dealership Network		
580 fully staffed dealership locations across the U.S.		

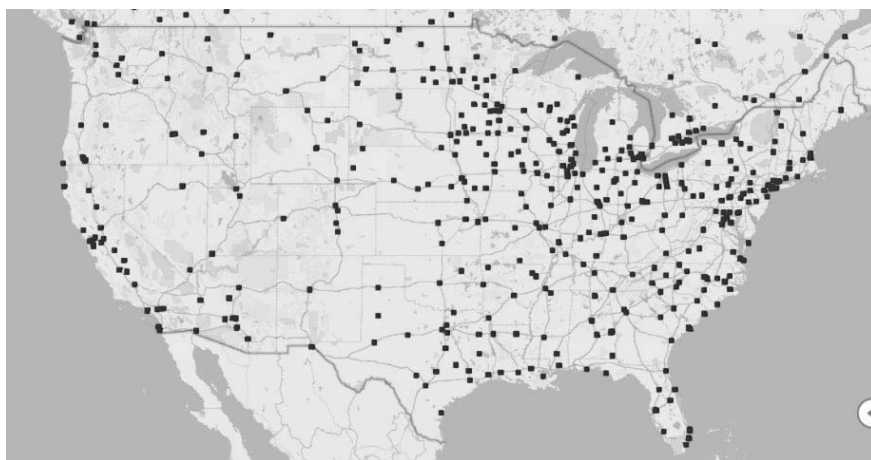

Service/Support and Distribution Centers: Provide the type (service/support or distribution) and location of centers that support the United States by completing the following: *(To insert more rows, hit the tab key from the last field in the State column.)*

Center Type	City	State
Please see the above referenced map, each of the 580 locations is an authorized service location.		
To identify the closest dealership please visit Bobcat.com/dealer		

Marketing

Key Marketing Contact(s): List the name(s), title(s) and contact information of the business’s key national and regional marketing office(s). *(To insert more rows, hit the tab key from the last field in the Email column.)*

Name	Title	Phone	Email
Jesse Rheault	Government Account Manager	701-630-5134	Jesse.Rheault@Doosan.com
Barry Hanson	Government Account Manager	701-241-8793	Barry.Hanson@Doosan.com
Randy Fuss	Director of Government Accounts	701-241-8746	Randy.Fuss@Doosan.com

Other Marking points of contact may be internal to Bobcat Company or External, too many individually list.

Marketing Activities: Describe how this business marketed its products and services to schools, nonprofit organizations and other public sector audiences in Fiscal Year 2018– 2019 (July 1 – June 30). List all conventions, conferences and other events at which this company exhibited.

Bobcat Company, is the industry leader in the design, manufacture, marketing and distribution of compact equipment. Among other methods, we utilize Online Display Ads, E-Blasts, E-newsletters and other digital advances to deliver our message to customers in the education, not-for-profit and other public sector industries.

Among others, Bobcat Company has a presence at the below national conferences: CAPPO - California Assoc. of Public Procurement Officials, NASPO Exchange, 2018 National Hurricane Conference, NY Gov Buy, APWA N/A Snow Conference, 2018 Navy Contracting Summit, Southeastern States Equipment Managers Conference, GFX (Gov. Fleet Expo), NACO (National Assoc. of Counties), NIGP, etc.

Cooperative Marketing: Describe ways in which this business can collaborate with AEPA Member Agencies in marketing the bid. Submit a marketing plan, titled Exhibit B – Marketing Plan, that would entail at a minimum, the following with their response: process on how the contract will be launched to current and potential agencies, the ability to produce and maintain in full color print advertisements in camera-ready electronic format, including company logos and contact information, anticipated contract announcements, planned advertisements, industry periodicals, other direct or indirect marketing activities promoting the AEPA awarded contract, and how the contract award will be displayed/linked on the Bidder’s website.

Bobcat Company leads the industry in the design, manufacture, marketing and distribution of compact equipment for construction, rental, landscaping, agriculture, grounds maintenance, government, utility, industry and mining. Some methods of marketing this cooperative to schools include:

- a) Through internal and field staff promotions and in communication directly with the customers and end users.
- b) Committed marketing staff for marketing material creation and promotional guidelines
- c) Marketing material and literature that is current/up to date with current product and promotional offerings to include logos and contract numbers.
- d) Marketing Tactics; Print Media, Online Display Ads, E-Blasts, E-newsletter, Social Media
- e) Bobcat Dealer Net for dealers to access government sales tools such as an explanation of the of benefits and process for purchasing from the cooperative.

Sales Training: Explain how your business will educate your salesforce staff on the AEPA contract including timing, methods, etc.

Bobcat Company conducts government sales training regionally and nationally that includes focused training at the corporate, dealership or territory level. This world class training includes onsite training with dealer (sales representatives, sales management, and staff), Dealer Account Managers, Regional Directors and Corporate Sales and Service Representatives. Training will be conducted in a variety of mediums to include onsite interactive training, video teleconference, and webinars. The training encompasses a wide range of government sales topics such as;

- a) Government Market Segment Overview
- b) Government Sector Engagement
- c) Government Spending Trends
- d) Changes in Buying Behaviors and the value of Contract Selling
- e) Contract Execution
- f) Contract Compliance to include Quoting, Ordering, Invoicing, and Delivery

Environmental Initiatives

Describe how your products and/or services support environmental goals.

Bobcat Company adheres to the Occupational Health & Safety Management, Environmental Management System – ISO 14001:2015 to control environmental risk associated with the manufacture of compact industrial, construction and agricultural equipment, and attachments at the Bobcat facilities.

Furthermore, the Acceleration Center, located in Bismarck, ND is one of only a handful of test lab facilities of its kind to receive a excel and achieve LEED Certification a widely used green building rating system and is a globally recognized symbol of sustainability achievement.

Describe the business’s “green” objectives (i.e. LEED, reducing footprint, etc.).

Bobcat Company As mentioned above, Bobcat Company’s Acceleration Center located in Bismarck, ND is Leed Certified.

Independent Subcontractors, Distributors, Installers, etc.

If the Bidder is not the sole provider of all goods and services provided under this contract, the following **must be answered**:

Selection Criteria for Independent Providers: Describe the criteria and process by which the business selects, certifies and approves subcontractors, distributors, installers and other independent services.

Bobcat Company

Bobcat Company has long believed that a strong dealer organization plays a strategic role, and has invested heavily in developing a dealer network that is unsurpassed. In dealer circles, Bobcat has a reputation for working with – partnering – with its dealers. The result is a strong core group of dealers who are passionate about building and strengthening the Bobcat brand worldwide.

Where once people thought “skid-steer loaders” when they heard the name “Bobcat”, today the brand stands behind nine different product types and dozens of different models, not to mention hundreds of job-matched attachments. Those different product types are sold into nearly every imaginable application. All of that adds up to tremendous business opportunities for Bobcat dealers.

Because we are committed to a successful, long term partnership with our dealers – we have high expectations of potential dealer applicants that will ensure this success and continue to enhance the Bobcat experience. These expectations include (but are not limited to): Minimum capital and financial requirements, Location and facility requirements (existing or new), Operational and staffing requirements, Branding requirements

Current Subcontractors, Distributors, Installers, etc.: Provide a list of current subcontractors, distributors, installers and other independent service providers who are contracted to perform the type of work outlined in this bid in the member agency states (listed in Part A of this IFB). Include, if applicable, contractor license or certificate information and the state(s) wherein they are eligible to provide services on behalf of the business.

Bobcat Company

Please review the map included under the heading “Sales Force” for additional details or to locate the dealership closest to your location, please visit <https://www.bobcat.com/dealer>.

Disclosures

Line of Credit Letter or Annual Financial Report (REQUIRED): Attach a letter from the business’s chief financial institution indicating the current line of credit available to the business and evidence of financial stability for the past three calendar years (2016, 2017 and 2018). This letter should state the line of credit as a range (i.e. “credit in the low six figures” or “a credit line exceeding five figures”). If company is a publicly traded company a complete Annual Financial Report is required in place of Line of Credit Letter.

Alternatively, Bidders may choose to send the Letter of Line of Credit and/or Annual Report by email directly to the AEPA Executive Director, George Wilson, at georgewilson.aepa@outlook.com. The Letter of Line of Credit and/or Annual Report must be received by the Executive Director before the due date and time of the bid opening.

Bobcat Company’s Current Financial report is attached but can also be accessed at <http://www.doosanbobcat.com/en/ir/finance/audit-report/>

Legal: Does this business have actions currently filed against it?

 X No Yes

If **Yes**, **AN ATTACHMENT IS REQUIRED**: List and explain current actions, such as, Federal Debarment (on US General Services Administration’s “Excluded Parties List”), appearance on any state or federal delinquent taxpayer list, or claims filed against the retainage and/or payment bond for projects.

References

Provide contact information of your business’s five largest public agency customers:

Agency	Name	Title	Phone Number	Email
1. State of Minnesota	Jeffrey Combs	Buyer II	(651) 201-2447	Jeffrey.Combs@state.mn.us
2. State of Missouri	Tom Veasman	Contract Administrator	573-522-4404	Tom.Veasman@modot.mo.gov
3. Florida Sheriffs Association	Annette Grissom	Cooperative Purchasing Program Coordinator II	850-877-2165	agrissom@flsheriffs.org
4. State of Kansas	Todd Herman	Procurement Officer	785-296-2375	Todd.Herman@ks.gov
5. H-GAC	Tammy Metty	Lead Program Coordinator	713-499-6663	tammy.metty@h-gac.com

Service Questionnaire

The following chart indicates which AEPA Member States intend to participate in this bid category. Respond to Yes/No and choice questions by using an (X). **Note: A Bidder must be *willing and able* to deliver the proposed products and/or services to 90% of the participating AEPA Member States, unless otherwise stated within Part B Technical Specifications. .**

AEPA Member States	Participating in this bid category?	Has the bidding company sold products/services in these states for the past three (3) years? (Yes or No)	If awarded, which states does the bidding company propose to sell in? (Place an X where applicable)	Indicate which states the bidding company has sales reps, distributors or dealers in. (Place an X where applicable)
California	Yes	Yes	X	X
Colorado	Yes	Yes	X	X
Connecticut	Yes	Yes	X	X
Florida	Yes	Yes	X	X
Georgia	Yes	Yes	X	X
Illinois	No	Yes	X	X
Indiana	Yes	Yes	X	X
Iowa	Yes	Yes	X	X
Kansas	Yes	Yes	X	X
Kentucky	Yes	Yes	X	X
Massachusetts	Yes	Yes	X	X
Michigan	Yes	Yes	X	X
Minnesota	Yes	Yes	X	X
Missouri	Yes	Yes	X	X
Montana	Yes	Yes	X	X
Nebraska	Yes	Yes	X	X
New Jersey	Yes	Yes	X	X
New Mexico	Yes	Yes	X	X
North Dakota	Yes	Yes	X	X
Ohio	Yes	Yes	X	X
Oregon	Yes	Yes	X	X
Pennsylvania	Yes	Yes	X	X
Texas	Yes	Yes	X	X
Virginia	Yes	Yes	X	X
Washington	Yes	Yes	X	X
West Virginia	Yes	Yes	X	X
Wisconsin	Yes	Yes	X	X
Wyoming	Yes	Yes	X	X

e-Commerce: Does this business have an e-commerce website? _____ **No** X **Yes**

If YES, what is the website? Bobcat.com

Customer and Support Service: It is understood depending on the type, kind and level of products and/or services being proposed in response to this bid will impact and determine the type and level of services required and these are identified in Part B Bid Specifications of this IFB.

Does this business have online customer support options? _____ **No** X **Yes**

Does this business have a toll-free customers support phone option? _____ **No** X **Yes**

Does this business offer local customer and support service options? _____ **No** X **Yes**

Training: If applicable, does this business offer customer training for the products and services sold? _____ **No** X **Yes**

If YES, describe what types/kinds of training you offer, the venues where training occurs and the location(s) of your trainers, include number of staff dedicated to training and their qualifications and hours of operation.

Bobcat Company

With each machine delivered, the delivering point of contact will provide initial standard operator and maintenance training during the walk around of the equipment. Additionally, we offer "Train the Trainer" type modules on CD that are available for our customers. These modules extensively cover the operations, safety, and maintenance of our equipment.

Finally, for larger audiences, we have a corporate training staff that stands ready to provide optional specialize, in-depth, and interactive training for a minimal cost (travel and materials).

Pricing:

Is your pricing methodology guaranteed for the term of the contract? _____ **No** X **Yes**

Will you offer customized price lists to participating entities as required per the pricing terms of Part A? _____ **No** X **Yes**

Will you offer hot list pricing (optional) as described in the pricing terms of Part A? X **No** _____ **Yes**

Will you offer volume price discounts as described in the pricing terms of Part A? _____ **No** X **Yes**

Competitiveness: In order for your bid to be considered, your company must offer AEPA prices that are equal to or lower than those normally offered to individual entities or cooperatives with equal or lower volume.

Is the pricing that is proposed to AEPA equal to or lower than pricing your company offers to individual entities or cooperatives with equal to or lower volume? _____ **No** X **Yes**

Indicate which of the following apply and the **level of competitive range** you are offering in response to this IFB.

X Pricing offered to AEPA is EQUAL TO pricing offered to individual customer and/or cooperatives.

_____ Pricing is LESS THAN individual customer and/or cooperatives. Lower by _____%

Cooperative Contracts: Does your business currently have contracts with other cooperatives (local, regional, state, national)? _____ **No** X **Yes**

If YES, identify which cooperative and the respective expiration date(s).

Cooperative	Ultimate Expiration Date:
Florida Sheriffs Association	9/30/2021
NASPO	4/10/2023

Sourcewell	5/31/2023
HGAC	5/31/2021
NC Sheriffs Association	5/17/2021

If YES, and your business is awarded an AEPA contract, explain which contract your business will lead with in marketing and sales representative presentations (sales calls)?

Bobcat Company attempts to not make assertions to the customer regarding the priority of one cooperative or another, understanding procurement regulations is better left to the buying activity.

Administrative Fee: Which of the following best reflects how your pricing includes the individual AEPA Members' administrative fee. Mark with an "X".	
	The pricing for the products and/or services are the same for each AEPA Member Agency, shipping, handling, administrative fee and other specific state costs are added to arrive at total price offered to the Individual AEPA Member Agency.
	The pricing for the products and/or services is inclusive of the administrative fee and therefore the pricing is the same for all AEPA Member Agencies. Shipping, handling and other state specific costs are added to the adjusted AEPA Member Agency's price.
X	The pricing for the products and/or services includes ALL (shipping, handling, administrative fee, other) costs to arrive at a single price for all AEPA Member Agencies.

Shipping & Handling: Orders that are \$50.00 or more shall include shipping and handling. What is the flat rate your company will charge, regardless of where shipped in the continental United States, for orders less than \$50.00?	\$0.00
---	---------------

Product Returns: Does your business have a return policy? No X Yes

If YES, describe your return policy and if you charge a restocking fee, what is it? (AEPA allows up to 15% for supplies and up to 25% for equipment).

Bobcat Company -Up to 25% - Exchange and returns rarely occur, however in the event that the situation(s) shall arise, Bobcat Company will work with the customer on a case by case basis. It is Bobcat Company's intent to create a world class customer experience and will work diligently with the customer(s) and dealer(s) to quickly provide resolution and minimize any disruption in the customer(s) operations.

Payment Terms: Will your business offer AEPA buyer's a quick pay discount? X No Yes

If YES, what is the discount? %Net

Leasing: Does your business offer leasing arrangements under this bid? X No Yes
If Yes, please indicate the rate factor and other cost factors below.

If an AEPA contract is approved and awarded by the Member Agencies, as a Vendor Partner, I agree to:

Responsibilities of an AEPA Vendor Partner	Yes, indicate with an "X"	No, indicate with an "X"
---	----------------------------------	---------------------------------

1. Designate and assign a dedicated senior-level contract manager (one authorized to make decisions) to each of the Member Agency accounts. This employee will have a complete copy and must have working knowledge of the AEPA contract.	X	
2. Train and educate sales staff on what the AEPA contract is: including pricing, who can order from the contract (by state), terms/conditions of the contract, and the respective ordering procedures for each state. It is expected that Vendor Partners will lead with AEPA contracts.	X	
3. Develop a marketing plan to support the AEPA contract in collaboration with respective AEPA Member Agencies. The marketing plan should include, but not be limited to, a website presence, electronic mailings, sales flyers, brochures, mailings, catalogs, etc.	X	
4. Create an AEPA-specific sell sheet with a space to add a Member Agency logo and contact information for use by the Member Agencies and the Vendor Partner's local sales representatives to market within each state.	X	
5. On a quarterly basis, complete the sales and administrative fee report (see attached PDF example) and submit to each Member Agency along with the respective administrative fees to be paid. If there are no sales, the Vendor Partner is required to submit a \$0 report to the AEPA Member Agency.	X	
6. Have ongoing communication with the Bid Oversight Chairperson, AEPA Member Agencies and the Member Agencies Participating Entities.	X	
7. Attend two (2) AEPA meetings each year (see Part A)	X	
8. Participate in national and local conference trade shows to promote the AEPA contracts including, but not limited to the Association of School Business Officials (ASBO), the National Institute of Governmental Purchasing (NIGP), and the National Association of Educational Procurement (NAEP).	X	
9. Increase sales over the term of the contract with all participating AEPA Member Agencies.	X	

Deviations

Definition: Deviations can be defined as a major variance, change, or substitution submitted by a Bidder, which deviates from, adds extraneous terms to, conflicts with or offers an alternative to any term, condition, specification or requirement of this solicitation.

Instructions:

1. If “no” is marked with an “X” below, complete this form by signing it at the bottom.
2. If “yes” is marked with an “X” below, insert answers into the form shown below, providing narrative explanations of deviations. *(To insert more rows, hit the tab key from the last field in the last row and column.)*
3. If adding pages, the bidder’s name and identifying information as to which item the response refers must appear on each page.
4. Deviations to local, state or federal laws cannot be accepted under this bid.

	No , this bidder does not have deviations (exceptions or alternates) to the specifications listed in Part B of this IFB.
X	Yes , this bidder has the following deviations to the specifications listed in Part B of this IFB.

Outline Number Part B	Specification (describe)	Details of Deviation
Contract Cover Page	Right to inventions made under a contract or agreement	Bobcat Company does not waive its right to possess it’s intellectual property.
Contract Cover Page	Profit as a separate element of Price	Our products are commercially available. I believe this is a construction or service prescription not applicable to equipment items.



Association of Educational
PURCHASING AGENCIES

Part E – Signature Forms

AEPA IFB 020-E

Lawn & Groundskeeping Equipment, Supplies & Services

Instructions

Contained herein are forms that require a signature from an authorized person at your company. All items found within this document are **mandatory**. Failure to sign the required areas, sections, or signature lines will allow AEPA to consider your company's proposal as **non-responsive**.

To submit the required signed forms, follow these steps:

1. Read the documents in their entirety.
2. Complete all forms and sign when required.
3. Once signed, place notary stamp in the delegated area on the Bid Affidavit.
4. Return the forms and pages in their correct order and scan one (1) single PDF format titled "Part E – Signature Forms – Name of Bidding Company" (i.e. one PDF document for all signature forms).
5. Submit Part E, along with other required documents in Public Purchase.

AEPA does not allow electronic signatures.

*Note, a bid checklist has been provided to review with your submission.

The following sections will need to be completed prior to submission as one (1), single PDF titled "Part E – Signature Forms – Name of Bidding Company".

Uniform Guidance "EDGAR" Certification Form – *signature required

Bid Affidavit – *signature required

Acceptance of Bid & Contract Award – *signature required

Uniform Guidance “EDGAR” Certification Form

2 CFR Part 200

When a purchasing agency seeks to procure goods and services using funds under a federal grant or contract, specific federal laws, regulations, and requirements may apply in addition to those under state law. This includes, but is not limited to, the procurement standards of the Uniform Administrative Requirements, Cost Principles and Audit Requirements for Federal Awards, 2 CFR 200, referred to as the “Uniform Guidance” or new “EDGAR”. All bidders submitting proposals must complete this EDGAR Certification form regarding the bidder’s willingness and ability to comply with certain requirements, which may be applicable to specific agency purchases using federal grant funds.

For each of the items below, the Bidder will certify its agreement and ability to comply, where applicable, by having the bidder’s authorized representative check, initial the applicable boxes, and sign the acknowledgement at the end of this form. If a bidder fails to complete any item of this form, AEPA will consider and may list the response, as the bidders is unable to comply. A “No” response to any of the items below may influence the ability of a purchasing agency to purchase from the bidder using federal funds.

1. Violation of Contract Terms and Conditions

Provisions regarding bidder default are included in AEPA’s terms and conditions. Any contract award will be subject to such terms and conditions, as well as any additional terms and conditions in any purchase order, ancillary agency contract, or construction contract agreed upon by the bidder and the purchasing agency, which must be consistent with and protect the purchasing agency at least to the same extent as AEPA’s terms and conditions. The remedies under the contract are in addition to any other remedies that may be available under law or in equity.

2. Termination for Cause of Convenience

For a participating agency purchase or contract in excess of \$10,000 made using federal funds, you agree that the following term and condition shall apply:

The participating agency may terminate or cancel any purchase order under this contract at any time, with or without cause, by providing seven (7) business days in advance written notice to the bidder. If this agreement is terminated in accordance with this paragraph, the participating agency shall only be required to pay bidder for goods and services delivered to the participating agency prior to the termination and not otherwise returned in accordance with the bidder’s return policy. If the participating agency has paid the bidder for goods and services provided as the date of termination, bidder shall immediately refund such payment(s).

If an alternate provision for termination of a participating agency’s purchase for cause and convenience, including the manner by which it will be effected and the basis for settlement, is in the participating agency’s purchase order, ancillary agreement or construction contract agreed to by the bidder, the participating agency’s provision shall control.

3. Equal Employment Opportunity

Except as otherwise provided under 41 CFR Part 60, all participating agency purchases or contract that meet the definition of “federally assisted construction contract” in 41 CFR Part 60-1.3 shall be deemed to include the equal opportunity clause provided under 41 CFR 60-1.4(b), in accordance with Executive Order 11246, “Equal Employment Opportunity” (30 FR 12319, 12935, 3 CFR Part, 1964-1965 Comp., p. 339), as amended by Executive Order 11375, “Amending Executive Order 11246 Relating to Equal Employment Opportunity,” and implementing regulations at 41 CFR Part 60, “Office of Federal Contract Compliance Programs, Equal Employment Opportunity, Department of Labor.”

The equal opportunity clause provided under 41 CFR 60-1.4(b) is hereby incorporated by reference. Bidder agrees that such provision applies to any participating agency purchase or contract that meets the definition of “federally assisted construction contract” in 41 CFR Part 60-1.3 and bidder agrees that it shall comply with such provision.

4. Davis Bacon Act

When required by Federal program legislation, bidder agrees that, for all participating agency contracts for the construction, alteration, or repair (including painting and decorating) of public buildings or public works, in excess of \$2,000, bidder shall comply with the Davis-Bacon Act (40 U.S.C. 3141-3144, and 3146-3148) as supplemented by Department of Labor regulations (29 CFR Part 5, "Labor Standards Provisions Applicable to Contracts Covering Federally Financed and Assisted Construction"). In accordance with the statute, bidder is required to pay wages to laborers and mechanics at a rate not less than the prevailing wages specific in a wage determinate made by the Secretary of Labor. In addition, bidder shall pay wages not less than once a week.

Current prevailing wage determinations issued by the Department of Labor are available at www.wdol.gov. Bidder agrees that, for any purchase to which this requirement applies, the award of the purchase to the bidder is conditioned upon bidder's acceptance of wage determination.

Bidder further agrees that is shall also comply with the Copeland "Anti-Kickback" Act (40 U.S.C. 3145), as supplemented by Department of Labor regulations (29 CFR Part 3, "Contractors and Subcontractors on Public Building or Public Work Financed in Whole or in Part by Loans or Grants from the United States"). The Act provides that each construction completion, or repair of public work, to give up any part of the compensation to which he is otherwise entitled under his contract of employment, shall be defined under this titled or imprisoned not more than five (5) years, or both.

5. Contract Work Hours and Safety Standards Act

Where applicable, for all participating agency purchases in excess of \$100,000 that involve the employment of mechanics or laborers, bidder agrees to comply with 40 U.S.C. 3702 and 3704, as supplemented by Department of Labor regulations (29 CFR Part 5). Under 40 U.S.C. 3702 of the Act, bidder is required to compute the wages of every mechanic and laborer on the basis of a standard work week of 40 hours. Work in excess of the standard work week is permissible provided that the worker is compensated at a rate of not less than one and a half times the basic rate of pay for all hours worked in excess of 40 hours in the work week. The requirements of the 40 U.S.C. 3704 are applicable to construction work and provide that no laborer or mechanic must be required to work in surroundings or under working conditions that are unsanitary, hazardous or dangerous. These requirements do not apply to the purchase of supplies, materials or articles ordinarily available on the open market, or contracts for transportation or transmission of intelligence.

6. Right to Inventions Made Under a Contract or Agreement

If the participating agency's federal award meets the definition of "funding agreement" under 37 CFR 401.2(a) and the recipient or sub recipient wishes to enter into a contract with a small business firm or nonprofit organization regarding the substitution of parties, assignment or performance or experiments, developmental or research work under the "funding agreement," the recipient or sub recipient must comply with the requirements of 37 CFR Part 401, "Rights to Inventions Made by Nonprofit Organizations and Small Business Firms Under Government Grants, Contracts and Cooperative Agreements," and any implementing regulations issued by the awarding agency.

7. Clean Air Act and Federal Water Pollution Control Act

Clean Air Act (42 U.S.C. 7401-7671q.) and the Federal Water Pollution Control Act (33 U.S.C. 1251-1387), as amended, contracts and sub grants of amounts in excess of \$150,000 must contain a provision that requires the non-Federal award to agree to comply with all applicable standards, orders, or regulations issued pursuant to the Clean Air Act (42 U.S.C. 7401-7671q.) and the Federal Water Pollution Control Act, as amended (33 U.S.C. 1251-1387). Violations must be reported to the Federal awarding agency and the Regional Office of the Environmental Protection Agency (EPA). When required, bidder agrees to comply with all applicable standards, orders, or regulations issued pursuant to the Clean Air Act and the Federal Water Pollution Control Act.

8. Debarment and Suspension

Debarment and Suspension (Executive Orders 12549 and 12689), a contract award (see 2 CFR 180.222) must not be made to parties listed on the government-wide exclusions in the System for Award Management (SAM), in accordance with OMB guidelines at 2 CFR 180 that implement Executive Orders 12549 (3 CFR Part 1966 Comp. p. 189) and 12689 (3 CFR Part 1989 Comp. p. 235), "Debarment and Suspension." SAM exclusions contain the names of parties debarred, suspended, or otherwise excluded by agencies, as well as parties declared ineligible under statutory or regulatory authority other than Executive Order 12549. Bidder certifies that the bidder is not current listed and further agrees to immediately notify AEPA and all participating agencies with pending purchases or seeking to purchase from the bidder if bidder is later listed on the government-wide exclusions in SAM, or is debarred, suspended, or otherwise excluded by agencies or declared ineligible under statutory or regulatory authority other than Executive Order 12549.

9. Byrd Anti-Lobbying Amendment

Byrd Anti-Lobbying Amendment (31 U.S.C. 1352), bidders that apply or bid for an award exceeding \$100,000 must file the required certification. Each tier certifies to the tier above that it will not and has not used Federal appropriated funds to pay any person or organization for influencing or attempting to influence an officer or employee of any agency, a member of Congress, officer or employee of Congress, or an employee of a member of Congress in connection with obtaining any Federal contract, grant or any other award covered by 31 U.S.C. 1352. Each tier must also disclose any lobbying with non-Federal funds that take place in connection with obtaining any Federal award. Such disclosures are forwarded from tier to tier up to the non-Federal award.

10. Procurement of Recovered Materials

For participating agency purchases utilizing Federal funds, bidder agrees to comply with Section 6002 of the Solid Waste Disposal Act, as amended by the Resource Conservation and Recovery Act where applicable and provide such information and certifications as a participating agency may require to confirm estimates and otherwise comply. The requirements of Section 6002 include procuring only items designated in guidelines of the Environmental Protection Agency (EPA) at 40 CFR Part 247 that contain the highest percentage of recovered materials practicable, consistent with maintaining a satisfactory level of competition, where the purchase price of the item exceeds \$10,000 or the value of the quantity acquired during the preceding fiscal year exceeded \$10,000; procuring solid waste management services in a manner that maximizes energy and resource recover, and establishing an affirmative procurement program for procurement of recovered materials identified in the EPA guidelines.

11. Profit as a Separate Element of Price

For purchases using federal funds in excess of \$150,000, a participating agency may be required to negotiate profit as a separate element of the price. See 2 CFR 200.323(b). When required by a participating agency, bidder agrees to provide information and negotiate with the participating agency regarding profit as a separate element of the price for a particular purchase. However, bidder agrees that the total price, including profit, charged by the bidder to the participating agency shall not exceed the awarded pricing, including any applicable discount, under the bidders contract with AEPA.

12. General Compliance with Participating Agencies

In addition to the foregoing specific requirements, bidder agrees, in accepting any purchase order from a participating agency, it shall make a good faith effort to work with participating agency to provide such information and to satisfy requirements as may apply to a particular purchase or purchases including, but not limited to, applicable record keeping and record retention requirements as noted in the Federal Acquisition Regulation, FAR 4.703(a).

By **initialing the table (1-12)** and **signing below**, I certify that the information in this form is true, complete and accurate and that I am authorized by my business to make this certification and all consents and agreements contained herein.

Bidder Certification (By Item)	Bidder Certification: YES, I agree or NO, I do NOT agree	Initial
1. Violation of Contract Terms and Conditions	Yes, I agree	JRR
2. Termination for Cause of Convenience	Yes, I agree	JRR
3. Equal Employment Opportunity	Yes, I agree	JRR
4. Davis-Bacon Act	Yes, I agree	JRR
5. Contract Work Hours and Safety Standards Act	Yes, I agree	JRR
6. Right to Inventions Made Under a Contract or Agreement	No, I do not Agree	JRR
7. Clean Air Act and Federal Water Pollution Control Act	Yes, I agree	JRR
8. Debarment and Suspension	Yes, I agree	JRR
9. Byrd Anti-Lobbying Amendment	Yes, I agree	JRR
10. Procurement of Recovered Materials	Yes, I agree	JRR
11. Profit as a Separate Element of Price	No, I do not Agree	JRR
12. General Compliance with Participating Agencies	Yes, I agree	JRR

Clark Equipment Company dba Bobcat Company

Name of Business



Signature of Authorized Representative

Jesse Rheault

Printed Name

9/12/2019

Date

Bid Affidavit

Instructions: This form must be signed by the business's authorized representative and notarized below. If awarded, the Bidder is required to produce a copy of this document for each Member Agency with which it contracts.

1. The undersigned, is duly authorized to represent the persons, business and corporations joining and participating in the submission of the foregoing bid (such persons, business and corporations hereinafter being referred to as the bidder), being duly sworn, on his/her oath, states that to the best of his/her belief and knowledge no person, business or corporation, nor any person duly representing the same joining and participating in the submission of the foregoing bid, has directly or indirectly entered into any agreement or arrangement with any other bidders, or with any official of the **Member Agency**, or any employee thereof, or any person, business or corporation under contract with the **Member Agency** whereby the bidder, in order to induce the acceptance of the foregoing bid by the **Member Agency**, has paid, or is to pay to any other bidder, or to any of the aforementioned persons, anything of value whatever, and that the bidder has not, directly nor indirectly entered into any arrangement, or agreement, with any other bidder or bidders which tends to or does lessen or destroy free competition in the letting of the contract sought for by the foregoing bid.
2. This is to certify that the bidder, or any person on his/her behalf, has not agreed, connived, or colluded to produce a deceptive show of competition in the manner of the bidding, or award of the referenced contract.
3. This is to certify that neither I, nor to the best of my knowledge, information and belief, the bidder, nor any officer, director, partner, member or associate of the bidder, nor any of its employees directly involved in obtaining contracts with the **Member Agency**, or any subdivision of the state has been convicted of false pretenses, attempted false pretenses, or conspiracy to commit false pretenses, bribery, attempted bribery or conspiracy to bribe under the laws of any state or federal government for acts or omissions after January 1, 1985.
4. This is to certify that the bidder, or any person on his behalf has examined and understands the terms, conditions, scope of work and specifications, and other documents of this solicitation and that any and all exceptions have been noted in writing and have been included with the bid submittal.
5. This is to certify that if awarded a contract, the bidder will provide the equipment, commodities, and/or services to members and affiliate members of the Agency in accordance with the terms, conditions, scope of work and specifications and other documents of this solicitation in the following pages of this bid.
6. This is to certify that the bidder is authorized by the manufacturer(s) to sell all proposed products on a national basis.
7. This is to certify that we have completed, reviewed, approved and have included all information that is required of these bid forms.

Jesse Rheault

250 East Beaton Dr.

Authorized Representative (Please print or type)

Mailing Address

Government Account Manager

West Fargo, ND 58078

Title (Please print or type)

City, State, Zip

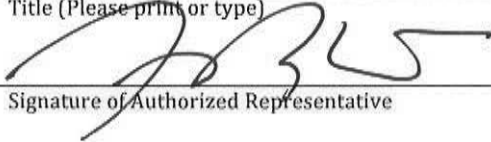

9/12/2019

Signature of Authorized Representative

Date

Subscribed and sworn to before me this

12th

day of

September, 2019

Notary Public in and for County of

Cass

State of

North Dakota

My commission expires on

12/27/22

Signature

Brianna Charles

BRIANNA CHARLES
Notary Public
State of North Dakota
My Commission Expires Dec. 27, 2022

Enter Notary Stamp



Acceptance of Bid & Contract Award

Instructions: PART I of this form is to be completed by the Bidder and signed by its Authorized Representative. PART II will be completed by the AEPA Member Agency only upon the occasion of the bid award. If approved by AEPA, the Bidder is required to produce a copy of the document for each of the AEPA Member Agency with which it contracts.

PART I: BIDDER

In compliance with the Invitation for Bid (IFB), the undersigned warrants that I/we have examined all Instructions to Bidders, associated documents, and being familiar with all of the conditions of the bid, hereby offer and agree to furnish all labor, materials, supplies and equipment incurred in compliance with all terms, conditions, specifications and amendments associated with this IFB and any written exceptions to the bid. Signature also certifies understanding and compliance with the certification requirements of the AEPA Member Agency's Terms and Conditions and/or Special Terms and Conditions. The undersigned understands that their competence, ability, capacity and obligations to offer and provide the proposed tangible personal property, professional services, construction services and other services on behalf of the Bidder Partner as well as other factors of interest to the AEPA Member Agency as stated in the evaluation section, will be a consideration in making the award.

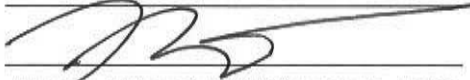
Business Name	Clark Equipment Company dba Bobcat Company	Date	9/12/2019
Address	250 East Beaton Dr.	City, State Zip	West Fargo, ND 58078
Contact Person	Jesse Rheault	Title	Government Account Manager
Authorized Signature		Title	Government Account Manager
Email	Jesse.Rheault@Doosan.com	Phone	701-630-5134

PART II: AWARDING MEMBER AGENCY

Your bid response for the above identified bid is hereby accepted. As a Bidder Partner you are now bound to offer and provide the products and services identified within this IFB, your response and approved by AEPA, including all terms, conditions, specifications, exceptions and amendments. As Bidder Partner, you are hereby not to commence any billable work or provide any products or services under this contract until an executed purchase order is received from the AEPA Member Agency or Participating Entities. The intent of this contract is to constitute the final and complete agreement between the AEPA Member Agency and Bidder Partner, and no other agreements, oral or otherwise, regarding the subject matter of this contract, shall bind any of the parties hereto. No change or modification of this contract shall be valid unless in writing and signed by both parties to this contract. If any provision of this contract is deemed invalid or illegal by any appropriate court of law, the remainder of this contract shall not be affected thereby. The initial term of this contract shall be for up to fifteen (15) months and will commence on the date indicated below and continue until February 28, 2021, unless terminated, canceled or extended. By mutual written agreement as warranted, the contract may be extended month by month up to six (6) months or for three (3) additional 12-month periods.

Awarding Agency _____

Authorized Representative _____

Awarded this	day of	Contract Number
Contract to commence		
(Member Agency to select)		Or March 1, 2020

Bid Checklist

Instructions: Utilize the checklist below, reviewing to confirm that all the required documents have been uploaded to Public Purchase, in their specified/required format, by the due date and time listed for this IFB. Bid submissions not following the specified/required format may result as being marked non-responsive and may not be considered for evaluation. Bidders are reminded that failure to follow, comply with, and adhere to the enclosed instructions of this solicitation may result in their response being deemed non-responsive. AEPA, its Member Agencies, affiliate agencies and authorized representatives are not responsible for bid proposals that are incomplete, unreadable, or received after the IFB deadline submission date.

"x"	Document Title, Uploaded to Public Purchase (Bidder must submit documents in the required title/format)	Format of Uploaded Document	Notes
	Bid Bond – if Required, see Part B if applicable.	Upload PDF copy. The original <u>must be</u> received by Oakland Public Schools by due date and time.	Send to Oakland Public Schools.
	Part C – State Specific Forms – Name of Bidding Company	Single, Scanned PDF	Required. Signatures Required.
	Part D - Questionnaire – Name of Bidding Company Includes: <ul style="list-style-type: none"> • Company Information • Service Questionnaire • Exceptions • Deviations 	Single, Scanned PDF	Required.
	Part E – Signature Forms – Name of Bidding Company Includes: <ul style="list-style-type: none"> • Uniform Guidance “EDGAR” Certification • Bid Affidavit • Acceptance of Bid & Contract Award 	Single, Scanned PDF	Required. Signatures required.
	Part F – Pricing Schedule – Name of Bidding Company	Excel Workbook	Required.
	Exhibit A – Annual Report/Letter of Credit – Name of Bidding Company	Scanned PDF	Required. Not provided by AEPA, Bidder Created
	Exhibit B – Marketing Plan – Name of Bidding Company	Scanned PDF	Optional. Not provided by AEPA, Bidder Created
	Exhibit C – Warranties, Additional Services – Name of Bidding Company	Scanned PDF	Optional. Not provided by AEPA, Bidder Created
	Exhibit D – Additional Discounts – Name of Bidding Company	Scanned PDF	Optional. Not provided by AEPA, Bidder Created



Part F.1 – Catalog Discount for Items in a Commercially Available Catalog

AEPA #020-E Lawn & Groundskeeping Equipment

Bidding Company Name:

Clark Equipment Company dba Bobcat Company

Name of Catalog:

(This must be the catalog in effect as of the bid date)

Price List - July 2019 - Bobcat Company

Note: Groupings to be defined by Bidder and can be by sub-category, manufacturer, etc.

Part F.1 is a REQUIRED FORM

No.	Grouping of Discount	Discount Offered for This Grouping	Comments
1	Bobcat® Compact Utility Tractors	20%	Factory installed options receive 20% off MSRP. All Attachments receive 24% off MSRP
2	Bobcat® Toolcats	20%	Factory installed options receive 20% off MSRP. All Attachments receive 24% off MSRP
3	Bobcat® Utility Vehicles	20%	Factory installed options receive 20% off MSRP. All Attachments receive 24% off MSRP



**Part F.2A – Core List Price Schedule
AEPA #020-E Lawn & Groundskeeping Equipment**

INSTRUCTIONS: Complete the following information for all core items listed below. These are higher usage items and it is anticipated that deeper discounts will be bid for these items. In the event a new catalog or manufacturer's price list changes during the contract term, the Bid Discount Percentage would not exceed the bid discount percentage.
Please be sure to set the 'Print Area' PRIOR to submitting your bid response.

NOTE: The Net Effective Price MUST be consistent with the percentage discounts listed on the F.1 tab. Failure to have price correspond may be cause for rejection of your offer.

Part F.2A is a REQUIRED FORM

Bidding Company Name:		Bobcat Company				Price List - July 2019 - Bobcat Company					
No.	Product Category	Product Description	Manufacturer	Manufacturer SKU	Vendor SKU	Unit of Measure	Catalog List Price	Bid Discount Percentage	Net Effective Bid Price	Comments	No.
1	Turf Vehicles & Attachments	Utility Vehicle/Tractor: A gas or diesel-powered all-purpose conveyance, capable of accepting multiple types of attachments for turf management and landscaping tasks. Uses drop-bar, pivot-pin, or three-point hitches for attachments. Engine strength of approximately 60 hp. Fuel capacity of approximately 15 gallons. Forward ground speed of approximately 20 mph. Includes hydraulics and lift capacity for approximately 2,200 pounds. Configured as base-vehicle, stock without any options. An example of a machine meeting these specifications would be the Toro Outcross 960 Turf Utility Vehicle or equivalent.	Bobcat® Toolcat	M1221	M1221	Each	\$53,404.00	20%	\$ 42,723.20	Please see the specifications included in Exhibit C for additional details.	1
2	Turf Vehicles & Attachments	Light Utility Vehicle: A gas-powered grounds and turf crossover vehicle, capable of accepting attachments and multiple types of configurations, such as cabs, beds, seat extensions, lifts, and racks. Powered by an engine, sized approximately at 430cc with a fuel tank of approximately five gallons. Forward ground speed of approximately 16 mph. Towing capacity of approximately 1,500 pounds. Hydraulic disk brakes. Provide pricing for a vehicle configured with four-person bench seating, windshield, and four-foot flat bed, no canopy. An example of a machine meeting these specifications would be the Toro Gas-Powered Workman GTX or equivalent.	Bobcat® 3400 UTV	M1303	M1303	Each	\$ 13,420.00	20%	\$ 10,736.00	Please see the specifications included in Exhibit C for additional details.	2
3	Turf Vehicles & Attachments	Reel Mower Gang Attachment with Seven Blades: Mowing width of approximately 14 feet. Variable height adjustments. Capable of mowing approximately 10.5 acres per hour for semi-formal cuts. An example of a machine meeting these specifications would be the Toro Reelmaster Model 01007, configured as 16" diameter w/ Semi-pneumatic Wheels, Model 01304 or equivalent.				Each			\$ -		3



Part F.2B - Non-Core Price Schedule AEPA #020-E Lawn & Groundskeeping Equipment

INSTRUCTIONS: Download the Net Effective Bid Price and respective information for all line items except the core items (listed on F.2A) in the entire catalog. Use a separate spreadsheet for each catalog. Please be sure to set the 'Print Area' PRIOR to submitting your bid response.

NOTE: The Net Effective Price MUST be consistent with the percentage discounts listed on the F.1 tab. Failure to have price correspond may be cause for rejection of your offer.

Part F.2B is a REQUIRED FORM

Bidding Company Name:		Bobcat Company				Catalog Name:				Price List - July 2019 - Bobcat Company			
No.	Product Category	Product Description	Manufacturer	Manufacturer SKU	Vendor SKU	Unit of Measure	Catalog List Price	Bid Discount Percentage	Net Effective Bid Price	Comments	No.		
1	Bobcat@ Compact Utility Tractor	CT1021HST COMPACT UTILITY TRACTOR	Bobcat Company	M1601		EA	\$ 11,527.00	20.0%	\$ 9,221.60	20% off Published MSRP of all factory installed options. 24% off attachments	1		
2	Bobcat@ Compact Utility Tractor	CT1025HST COMPACT UTILITY TRACTOR	Bobcat Company	M1602		EA	\$ 13,922.00	20.0%	\$ 11,137.60	20% off Published MSRP of all factory installed options. 24% off attachments	2		
3	Bobcat@ Compact Utility Tractor	CT2025HST COMPACT TRACTOR	Bobcat Company	M1603		EA	\$ 16,560.00	20.0%	\$ 13,248.00	20% off Published MSRP of all factory installed options. 24% off attachments	3		
4	Bobcat@ Compact Utility Tractor	CT2025MST COMPACT TRACTOR	Bobcat Company	M1604		EA	\$ 15,284.00	20.0%	\$ 12,227.20	20% off Published MSRP of all factory installed options. 24% off attachments	4		
5	Bobcat@ Compact Utility Tractor	CT2035HST COMPACT TRACTOR	Bobcat Company	M1605		EA	\$ 20,797.00	20.0%	\$ 16,637.60	20% off Published MSRP of all factory installed options. 24% off attachments	5		
6	Bobcat@ Compact Utility Tractor	CT2035MST COMPACT TRACTOR	Bobcat Company	M1606		EA	\$ 19,485.00	20.0%	\$ 15,588.00	20% off Published MSRP of all factory installed options. 24% off attachments	6		
7	Bobcat@ Compact Utility Tractor	CT2040HST COMPACT TRACTOR	Bobcat Company	M1607		EA	\$ 21,343.00	20.0%	\$ 17,074.40	20% off Published MSRP of all factory installed options. 24% off attachments	7		
8	Bobcat@ Compact Utility Tractor	CT2040MST COMPACT TRACTOR	Bobcat Company	M1608		EA	\$ 20,008.00	20.0%	\$ 16,006.40	20% off Published MSRP of all factory installed options. 24% off attachments	8		
9	Bobcat@ Compact Utility Tractor	CT2535HST COMPACT TRACTOR	Bobcat Company	M1609		EA	\$ 30,804.00	20.0%	\$ 24,643.20	20% off Published MSRP of all factory installed options. 24% off attachments	9		
10	Bobcat@ Compact Utility Tractor	CT2540HST COMPACT TRACTOR	Bobcat Company	M1611		EA	\$ 32,355.00	20.0%	\$ 25,884.00	20% off Published MSRP of all factory installed options. 24% off attachments	10		
11	Bobcat@ Compact Utility Tractor	CT4045HST COMPACT TRACTOR	Bobcat Company	M1613		EA	\$ 26,043.00	20.0%	\$ 20,834.40	20% off Published MSRP of all factory installed options. 24% off attachments	11		
12	Bobcat@ Compact Utility Tractor	CT4045SST COMPACT TRACTOR	Bobcat Company	M1614		EA	\$ 23,884.00	20.0%	\$ 19,107.20	20% off Published MSRP of all factory installed options. 24% off attachments	12		
13	Bobcat@ Compact Utility Tractor	CT4050HST COMPACT TRACTOR	Bobcat Company	M1615		EA	\$ 29,545.00	20.0%	\$ 23,636.00	20% off Published MSRP of all factory installed options. 24% off attachments	13		
14	Bobcat@ Compact Utility Tractor	CT4050SST COMPACT TRACTOR	Bobcat Company	M1616		EA	\$ 25,105.00	20.0%	\$ 20,084.00	20% off Published MSRP of all factory installed options. 24% off attachments	14		
15	Bobcat@ Compact Utility Tractor	CT4055SST COMPACT TRACTOR	Bobcat Company	M1617		EA	\$ 26,327.00	20.0%	\$ 21,061.60	20% off Published MSRP of all factory installed options. 24% off attachments	15		
16	Bobcat@ Compact Utility Tractor	CT4058SST COMPACT TRACTOR	Bobcat Company	M1618		EA	\$ 31,486.00	20.0%	\$ 25,188.80	20% off Published MSRP of all factory installed options. 24% off attachments	16		
17	Bobcat@ Compact Utility Tractor	CT5545E-HST COMPACT TRACTOR	Bobcat Company	M1619		EA	\$ 35,895.00	20.0%	\$ 28,716.00	20% off Published MSRP of all factory installed options. 24% off attachments	17		
18	Bobcat@ Compact Utility Tractor	CT5550E-HST COMPACT TRACTOR	Bobcat Company	M1620		EA	\$ 37,734.00	20.0%	\$ 30,187.20	20% off Published MSRP of all factory installed options. 24% off attachments	18		
19	Bobcat@ Compact Utility Tractor	CT5555E-HST COMPACT TRACTOR	Bobcat Company	M1621		EA	\$ 39,697.00	20.0%	\$ 31,757.60	20% off Published MSRP of all factory installed options. 24% off attachments	19		
20	Bobcat@ Compact Utility Tractor	CT5558E-HST COMPACT TRACTOR	Bobcat Company	M1622		EA	\$ 42,583.00	20.0%	\$ 34,066.40	20% off Published MSRP of all factory installed options. 24% off attachments	20		
21	Bobcat@ Mini-Track Loader	MT55 Mini Track Loader (Equipped with Tier 4 Engine)	Bobcat Company	M0045		EA	\$ 23,022.00	20.0%	\$ 18,417.60	20% off Published MSRP of all factory installed options. 24% off attachments	21		
22	Bobcat@ Mini-Track Loader	MT85 Mini Track Loader (Equipped with Tier 4 Engine)	Bobcat Company	M0113		EA	\$ 27,327.00	20.0%	\$ 21,861.60	20% off Published MSRP of all factory installed options. 24% off attachments	22		
23	Bobcat@ Toolcat™	5600 Turbo Utility Work Machine (Tier 4)	Bobcat Company	M1221		EA	\$ 53,404.00	20.0%	\$ 42,723.20	20% off Published MSRP of all factory installed options. 24% off attachments	23		
24	Bobcat@ Toolcat™	5610 Turbo Utility Work Machine - Deluxe (Tier 4)	Bobcat Company	M1223		EA	\$ 67,554.00	20.0%	\$ 54,043.20	20% off Published MSRP of all factory installed options. 24% off attachments	24		
25	Bobcat@ Utility Vehicle	3400 Utility Vehicle - Gas	Bobcat Company	M1303		EA	\$ 13,420.00	20.0%	\$ 10,736.00	20% off Published MSRP of all factory installed options. 24% off attachments	25		
26	Bobcat@ Utility Vehicle	3400XL Utility Vehicle - Gasoline	Bobcat Company	M1307		EA	\$ 15,440.00	20.0%	\$ 12,352.00	20% off Published MSRP of all factory installed options. 24% off attachments	26		

Bidding Company Name:			Bobcat Company				Catalog Name:			Price List - July 2019 - Bobcat Company			
No.	Product Category	Product Description	Manufacturer	Manufacturer SKU	Vendor SKU	Unit of Measure	Catalog List Price	Bid Discount Percentage	Net Effective Bid Price	Comments	No.		
27	Bobcat@ Utility Vehicle	UV34 Utility Vehicle- Diesel	Bobcat Company	M1501		EA	\$ 16,406.00	20.0%	\$ 13,124.80	20% off Published MSRP of all factory installed options. 24% off attachments	27		
28	Bobcat@ Utility Vehicle	UV34XL Utility Vehicle - Diesel	Bobcat Company	M1505		EA	\$ 17,886.00	20.0%	\$ 14,308.80	20% off Published MSRP of all factory installed options. 24% off attachments	28		
29											29		
30											30		
31											31		
32											32		
33											33		
34											34		
35											35		
36											36		
37											37		
38											38		
39											39		
40											40		
41											41		
42											42		
43											43		
44											44		
45											45		
46											46		
47											47		
48											48		
49											49		
50											50		
51											51		
52											52		
53											53		
54											54		
55											55		
56											56		
57											57		
58											58		
59											59		
60											60		
61											61		
62											62		
63											63		
64											64		
65											65		
66											66		
67											67		
68											68		
69											69		
70											70		
71											71		
72											72		
73											73		
74											74		
75											75		
76											76		
77											77		
78											78		
79											79		
80											80		
81											81		

BOBCAT COMPANY SUGGESTED PRICE LIST - 07-08-2019



Bobcat Company

ORDER ADDRESS:

CLARK EQUIPMENT COMPANY dba BOBCAT COMPANY
250 EAST BEATON DRIVE
PO BOX 6000
WEST FARGO, ND 58078-6000

Government Sales Points of Contact:

Phone:

Heather Messmer - Government Accounts Sales Support Mgr.
heather.messmer@doosan.com

(701) 241-8719

Jesse Rheault - Government Account Manager
jesse.rheault@doosan.com

(701) 241-8759

Barry Hanson - Government Account Manager
barry.hanson@doosan.com

(701) 241-8793

Randy Fuss - Director, Government Accounts
randy.fuss@doosan.com

(701) 241-8746

TOLL FREE #: 800-965-4232, Opt#2
FAX#: 701-280-7860

PROMPT PAYMENT TERMS: Net 30
TIME OF DELIVERY: 60 to 90 Days ARO
COMMERCIAL CREDIT CARD: Accepted (Visa/Mastercard/American Express)

TID#: 38-0425350

REMIT TO ADDRESS:

CLARK EQUIPMENT COMPANY dba BOBCAT COMPANY
75 REMITTANCE DR, SUITE 1130
CHICAGO, IL 60675-1130

Product		Discount Percent
MT		20.0%
MT Attachments		24.0%
Toolcat		20.0%
Toolcat Attachments		24.0%
Compact Tractors		20.0%
Compact Tractor Implements and Attachments		24.0%
Utility Vehicles		20.0%
UV Attachments		24.0%



Part Number	Mini Track Loader Description	SLP in US\$	Discount Percent	Labor	Price
-------------	-------------------------------	-------------	------------------	-------	-------

M0045	MT55 Mini Track Loader (Equipped with Tier 4 Engine)	\$23,022.00	20.0%	\$0.00	\$18,417.60
-------	--	-------------	-------	--------	-------------



Part Number	Factory Installed Options Description	SLP in US\$	Discount Percent	Labor	Price
-------------	---------------------------------------	-------------	------------------	-------	-------

M0045-R09-C02	9.8" Wide Track Option Machine width is 41.4"	\$691.00	20.0%	\$0.00	\$552.80
---------------	--	----------	-------	--------	----------

Part Number	Accessories Description	SLP in US\$	Discount Percent	Labor	Price
-------------	-------------------------	-------------	------------------	-------	-------

6737684	Ride-On Platform	\$536.00	20.0%	\$90.00	\$518.80
---------	------------------	----------	-------	---------	----------

CHOOSE BETWEEN TWO INTERFACES AS FOLLOWS:

7286202	Bobtach Interface	\$641.00	20.0%	\$90.00	\$602.80
7286203	Common Industry Interface	\$641.00	20.0%	\$90.00	\$602.80

Part Number	Mini Track Loader Description	SLP in US\$	Discount Percent	Labor	Price
-------------	-------------------------------	-------------	------------------	-------	-------

M0113	MT85 Mini Track Loader (Equipped with Tier 4 Engine)	\$27,327.00	20.0%	\$0.00	\$21,861.60
-------	--	-------------	-------	--------	-------------

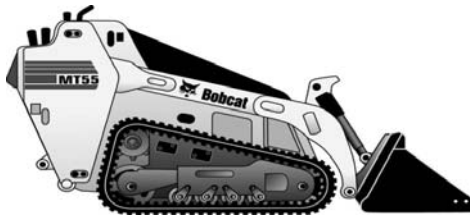

Part Number	Factory Installed Options Description	SLP in US\$	Discount Percent	Labor	Price
-------------	---------------------------------------	-------------	------------------	-------	-------

M0113-R09-C02	9.8" Wide Track Option Machine Width 41.4"	\$967.00	20.0%	\$90.00	\$863.60
---------------	---	----------	-------	---------	----------

CHOOSE BETWEEN TWO INTERFACES AS FOLLOWS:

7286202	Bobtach Interface	\$641.00	20.0%	\$90.00	\$602.80
7286203	Common Industry Interface	\$641.00	20.0%	\$90.00	\$602.80



Part Number	Adapter Plate Description	SLP in US\$	Discount Percent	Labor	Price
-------------	---------------------------	-------------	------------------	-------	-------

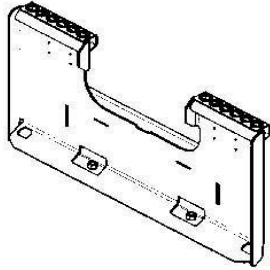

(MT50, MT52, MT55, MT85)

7100695	ADAPTER PLATE Installs on competitive attachment for use with Bobcat MT50 and MT52	\$513.00	24.0%	\$0.00	\$389.88
---------	--	----------	-------	--------	----------

Part Number	Angle Brooms Description	SLP in US\$	Discount Percent	Labor	Price
-------------	--------------------------	-------------	------------------	-------	-------

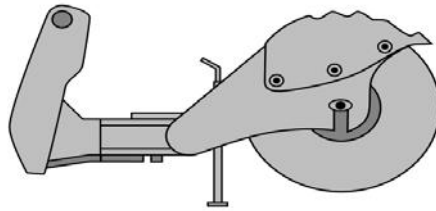

(MT52, MT55, MT85)

6907000	48" Angle Broom (Manual Angle, 3-Positions: 30° Right, Left and Straight) On MT85 must choose Bobtach interface	\$3,470.00	24.0%	\$0.00	\$2,637.20
---------	--	------------	-------	--------	------------

Part Number	Augers Description	SLP in US\$	Discount Percent	Labor	Price
-------------	--------------------	-------------	------------------	-------	-------



(MT52, MT55, MT85)

6808799	Model 10 Auger Drive Unit (Must also order Mounting Frame and Bit) (Must order mounting frame, light duty bit and swing stop kit when installing on MT50 and MT52)	\$1,453.00	24.0%	\$0.00	\$1,104.28
---------	--	------------	-------	--------	------------

6812946	AUGER 10 BOB-TACH MOUNTING FRAME (Includes Mounting Hardware) Swing Stop Kit may be needed which limits side to side swing of auger bit	\$486.00	24.0%	\$0.00	\$369.36
---------	---	----------	-------	--------	----------

(MT85) 7272933	AUGER 10 MTG BRACKET CII (Includes Mounting Hardware)	\$486.00	24.0%	\$0.00	\$369.36
-------------------	---	----------	-------	--------	----------

Auger Drive & Bit Recommendations

Model 10 Augers—Recommended bit size 6, 9”, 12”, 15”, 16”, 18”

Light Duty, Standard Duty, Heavy Duty and Rock Bits are Available.

Auger bit combinations should be used as a guideline. Recommendations are based upon average digging conditions.

Part Number	Backhoe Description	SLP in US\$	Discount Percent	Labor	Price
(MT52, MT55, MT85) 7101456	M06 Backhoe (Must also order Auxiliary Hydraulics Mode Switch, bucket and Mounting Kit)	\$7,123.00	24.0%	\$0.00	\$5,413.48
7101552	Backhoe Mounting Kit (Required when ordering M06 Backhoe - to be installed on MT 55)	\$176.00	24.0%	\$180.00	\$313.76

Part Number	Backhoe Buckets Description	SLP in US\$	Discount Percent	Labor	Price
(M06 Pin-on Style) 6715495	9" Trenching Bucket, 2 Bolt-On Teeth	\$432.00	24.0%	\$0.00	\$328.32
6715496	12" Trenching Bucket, 3 Bolt-On Teeth	\$479.00	24.0%	\$0.00	\$364.04

Part Number	Boring Unit Description	SLP in US\$	Discount Percent	Labor	Price
-------------	-------------------------	-------------	------------------	-------	-------

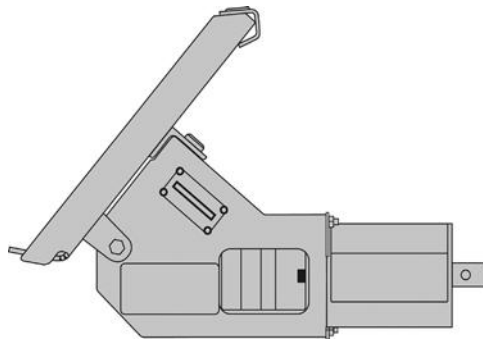

(MT52, MT55, MT85) 7110098	Boring Unit (Includes drive unit and guide tool)	\$2,412.00	24.0%	\$0.00	\$1,833.12
-------------------------------	--	------------	-------	--------	------------

Part Number	Breaker, Hydraulic Description	SLP in US\$	Discount Percent	Labor	Price
-------------	--------------------------------	-------------	------------------	-------	-------

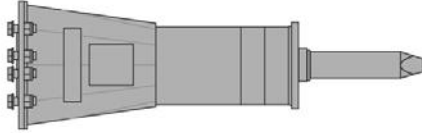

(MT52, MT55, MT85)

7113419	HB680 Breaker (Includes Nail Point, fixing cap bolts, cradle, isolation mount, gauge tool, retainer clip and hose protector) (Must also order Loader Mounting Frame and Hose Kit) (Special Applications Kit must be used when operating a Hydraulic Breaker) (When installing on MT50, must also order Shutdown Kit, p/n 6735945)	\$4,563.00	24.0%	\$0.00	\$3,467.88
---------	---	-------------------	--------------	---------------	-------------------

Mounting Frames –HB680

7113736	BOBTACH Loader Mounting Frame (Must also order a hose kit, P/N 6727411)	\$649.00	24.0%	\$0.00	\$493.24
7272954	Common Industry Interface Loader Mounting Frame - MI (Must also order a hose kit, P/N 6727411)	\$666.00	24.0%	\$0.00	\$506.16
7150181	Loader X-Change Mounting Frame (Uses X-Change pin-through design) (Must also order Breaker X-Change Mounting Cap p/n 7113656. This allows breaker with X-Change Mounting Cap to be installed on loader) (Must also order a hose kit, P/N 6727411)	\$953.00	24.0%	\$0.00	\$724.28
7113656	X-Change Mounting Cap	\$474.00	24.0%	\$0.00	\$360.24

Accessories – HB680

6727411	Hose Kit (Includes hoses and quick couplers)	\$186.00	24.0%	\$0.00	\$141.36
---------	--	-----------------	--------------	---------------	-----------------

Part Number	NB140 Breaker, Nitrogen Description	SLP in US\$	Discount Percent	Labor	Price
-------------	-------------------------------------	-------------	------------------	-------	-------

(MT50, MT52, MT55, MT85) (S70)

7355666	NB140 BREAKER (Includes Nail Point & fixing cap bolts) (Must also order Loader Mounting Frame and Hose Kit) (Special Applications Kit must be used when operating a Hydraulic Breaker) (When installing on MT50, must also order Shutdown Kit, p/n 6735945)	\$3,777.00	24.0%	\$0.00	\$2,870.52
---------	---	-------------------	--------------	---------------	-------------------

Mounting Frames –NB140

7113736	BOB-TACH LOADER MOUNTING FRAME (Must also order a hose kit, P/N 6727411)	\$649.00	24.0%	\$0.00	\$493.24
7272954	Breaker Frame CII, MT85 (Must also order a hose kit, P/N 6727411)	\$666.00	24.0%	\$0.00	\$506.16
7150181	Loader X-Change Mounting Frame (Uses X-Change pin-through design) (Must also order Breaker X-Change Mounting Cap p/n 7113656. This allows breaker with X-Change Mounting Cap to be installed on loader) (Must also order a hose kit, P/N 6727411)	\$953.00	24.0%	\$0.00	\$724.28
7113656	X-Change Mounting Cap	\$474.00	24.0%	\$0.00	\$360.24

Accessories – NB140

6727411	Hose Kit	\$186.00	24.0%	\$0.00	\$141.36
---------	----------	----------	-------	--------	----------

Part Number	Buckets Description	SLP in US\$	Discount Percent	Labor	Price
-------------	---------------------	-------------	------------------	-------	-------

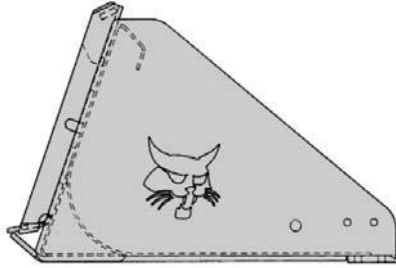

(MT52, MT55, MT85)

6731520	36" Constr./Ind. Bucket ♦ (Not approved for use with 32" Utility Grapple, P/N 6728117)	\$555.00	24.0%	\$0.00	\$421.80
7117432	36" Dirt Bucket ♦ (Not approved for use with 32" Utility Grapple, P/N 6728117)	\$529.00	24.0%	\$0.00	\$402.04
7117433	44" Dirt Bucket ♦	\$561.00	24.0%	\$0.00	\$426.36
7114488	36" General Purpose Bucket ♦ (For use with 32" Utility Grapple, P/N 7125370)	\$560.00	24.0%	\$0.00	\$425.60
7272912	Common Industry Interface - 36" General Purpose Bucket (MT55, MT85)	\$560.00	24.0%	\$0.00	\$425.60
7114581	44" General Purpose Bucket ♦ (For use with 32" Utility Grapple, P/N 7125370)	\$592.00	24.0%	\$0.00	\$449.92

(S70, MT85)

7117432	36" DIRT BUCKET	\$529.00	24.0%	\$0.00	\$402.04
7117433	44" DIRT BUCKET	\$561.00	24.0%	\$0.00	\$426.36
7114488	36" General Purpose Bucket ♦	\$560.00	24.0%	\$0.00	\$425.60
7114581	44" General Purpose Bucket ♦	\$592.00	24.0%	\$0.00	\$449.92
7272919	Common Industry Interface 44" General Purpose Bucket	\$592.00	24.0%	\$0.00	\$449.92
7114583	50" General Purpose Bucket	\$618.00	24.0%	\$0.00	\$469.68

♦ Buckets have holes predrilled to accept bolt-on cutting edges or bolt-on teeth.

Part Number	Digger Description	SLP in US\$	Discount Percent	Labor	Price
-------------	--------------------	-------------	------------------	-------	-------

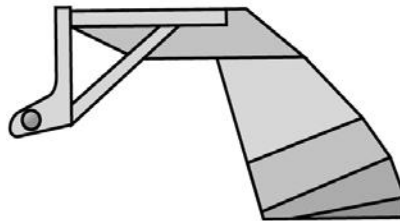

(MT50, MT52, MT55, MT85) (S70)

7100915	12S Digger	\$834.00	24.0%	\$0.00	\$633.84
---------	-------------------	----------	-------	--------	----------

Part Number	Dozer Blade Description	SLP in US\$	Discount Percent	Labor	Price
-------------	-------------------------	-------------	------------------	-------	-------

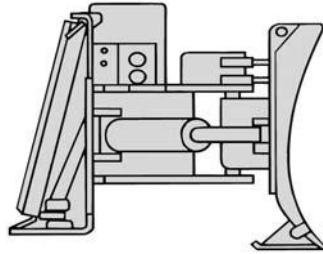

(MT50, MT52, MT55, MT85) (S70)

7196165	54" Utility Blade (with hydraulic angle) (To be used as either a Snow Blade or a Dozer Blade)	\$1,753.00	24.0%	\$0.00	\$1,332.28
---------	--	------------	-------	--------	------------

Part Number	Forks, Utility Description	SLP in US\$	Discount Percent	Labor	Price
-------------	----------------------------	-------------	------------------	-------	-------

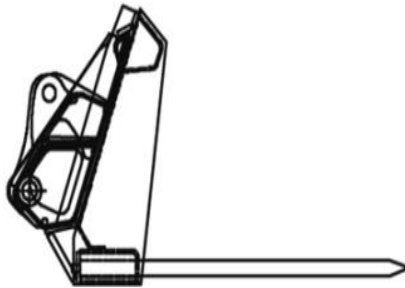

(MT50, MT52, MT55, MT85) (S70)

6727904	36" Utility fork, with 5 Teeth (Use with Farm/Utility grapple P/N 6728117) (Additional Forks (p/n 6717622) may be ordered).	\$861.00	24.0%	\$0.00	\$654.36
---------	--	----------	-------	--------	----------

Part Number	Grapple, Farm/Utility Description	SLP in US\$	Discount Percent	Labor	Price
-------------	-----------------------------------	-------------	------------------	-------	-------

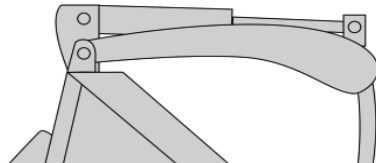

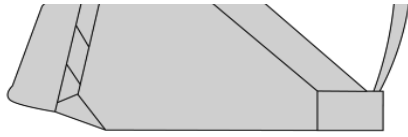

Farm Grapple with Bucket

Farm Grapple with Forks

(MT50, MT52, MT55, MT85) (S70)

6728117	Grapple, 32" Utility (Fits Current 36", 48" & 54" Utility Forks and 36" & 44" Utility Buckets) (Price includes \$360 for installation)	\$1,241.00	24.0%	\$360.00	\$1,303.16
7125370	Grapple, 32" (Fits Current 36" – 50" General Purpose buckets) (If bucket is equipped with a 6 hole step, must order a replacement 4 hole step, P/N 7103163) (Price includes \$360 for installation)	\$1,229.00	24.0%	\$360.00	\$1,294.04
7135737	36" Industrial Bucket Grapple (Bolt-On Cutting Edge included)	\$1,938.00	24.0%	\$0.00	\$1,472.88

It is recommended that a port relief be installed for use with grapples.
Installation instructions are included in the Operation Manual.

Optional Open/Close Restrictor is available to slow down the open/close functions of the combination bucket.

Part Number	Grapple, Root Description	SLP in US\$	Discount Percent	Labor	Price
-------------	---------------------------	-------------	------------------	-------	-------

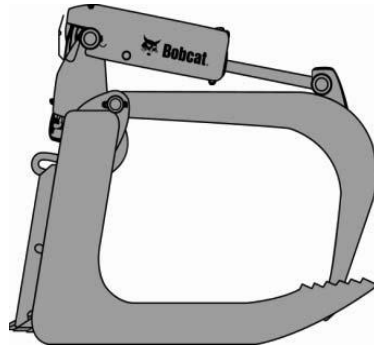

(MT52, MT55, MT85) (S70)

7134179	36" Root Grapple	\$1,994.00	24.0%	\$0.00	\$1,515.44
---------	-------------------------	------------	-------	--------	------------

It is recommended that a port relief be installed for use with grapples.
Installation instructions are included in the Operation Manual.

Optional Open/Close Restrictor is available to slow down the open/close functions of the combination bucket.

Part Number	Landplane Description	SLP in US\$	Discount Percent	Labor	Price
-------------	-----------------------	-------------	------------------	-------	-------



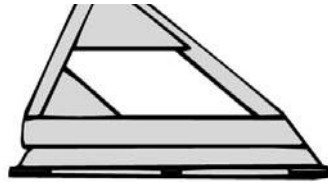

(MT50, MT52, MT55, MT85) (S70, S100) (T110)

6907173	48" Deluxe Landplane Leveling Attachment (Includes expanded metal grate, scarifier assembly, teeth and respective hardware)	\$1,267.00	24.0%	\$0.00	\$962.92
---------	---	------------	-------	--------	----------

Part Number	Pallet Forks Description	SLP in US\$	Discount Percent	Labor	Price
-------------	--------------------------	-------------	------------------	-------	-------

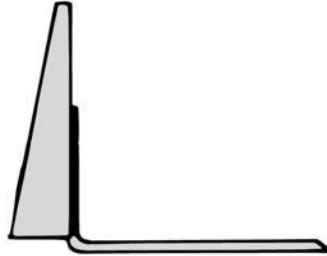

(MT50, MT52, MT55, MT85) (S70)

6809716	BOBTACH Pallet Fork Frame, less teeth	\$402.00	24.0%	\$0.00	\$305.52
7276448	Common Industry Interface - Pallet Fork Frame, less teeth	\$402.00	24.0%	\$0.00	\$305.52
6540184	36" Pallet Fork Teeth, Set of 2	\$274.00	24.0%	\$0.00	\$208.24

Part Number	Snow Blade Description	SLP in US\$	Discount Percent	Labor	Price
-------------	------------------------	-------------	------------------	-------	-------

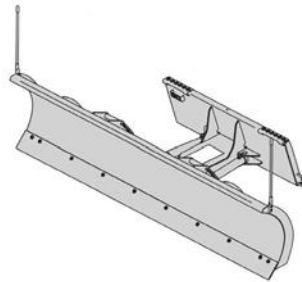

(MT50, MT52, MT55, MT85) (S70)

7196165	54" Utility Blade (with hydraulic angle) (To be used as either a Snow Blade or a Dozer Blade)	\$1,753.00	24.0%	\$0.00	\$1,332.28
---------	---	------------	-------	--------	------------

Part Number	Snowblower SB150 Description	SLP in US\$	Discount Percent	Labor	Price
-------------	------------------------------	-------------	------------------	-------	-------



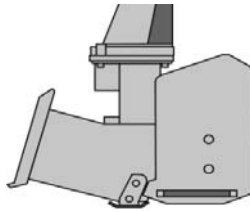

(MT52, MT55, MT85) (S70)

M7007	SB150 x 36" (Loader must be equipped with a Bobcat 14-Pin Attachment Control Kit) (Snowblower includes hydraulic motor package)	\$4,625.00	24.0%	\$0.00	\$3,515.00
--------------	--	-------------------	--------------	---------------	-------------------

(MT52, MT55, MT85) (S70, S100) (T110)

M7008	SB150 x 48" (Loader must be equipped with a Bobcat 14-Pin Attachment Control Kit) (Snowblower includes hydraulic motor package)	\$4,780.00	24.0%	\$0.00	\$3,632.80
--------------	--	-------------------	--------------	---------------	-------------------

Part Number	Soil Conditioner Description	SLP in US\$	Discount Percent	Labor	Price
--------------------	-------------------------------------	--------------------	-------------------------	--------------	--------------

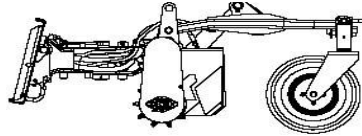

(MT52, MT55, MT85)

6958310	48" Soil Conditioner, Manual Angle	\$6,671.00	24.0%	\$0.00	\$5,069.96
----------------	---	-------------------	--------------	---------------	-------------------

Part Number	Stump Grinder Description	SLP in US\$	Discount Percent	Labor	Price
--------------------	----------------------------------	--------------------	-------------------------	--------------	--------------

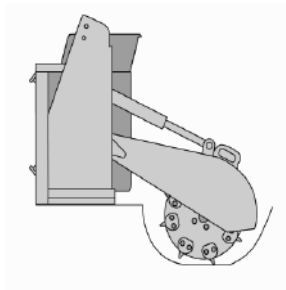

(MT50, MT52, MT55, MT85) (S70)

7100641	SG30 Stump Grinder (Loader must be equipped with a 14-Pin Attachment Control Kit)	\$5,275.00	24.0%	\$0.00	\$4,009.00
----------------	---	-------------------	--------------	---------------	-------------------

Part Number	Sweeper Description	SLP in US\$	Discount Percent	Labor	Price
--------------------	----------------------------	--------------------	-------------------------	--------------	--------------

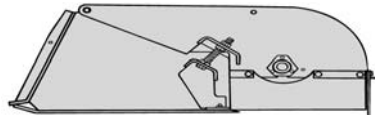

(MT55, MT85) (S70)

7138898	44" Sweeper	\$3,388.00	24.0%	\$0.00	\$2,574.88
----------------	--------------------	-------------------	--------------	---------------	-------------------

Part Number	Tiller Description	SLP in US\$	Discount Percent	Labor	Price
--------------------	---------------------------	--------------------	-------------------------	--------------	--------------

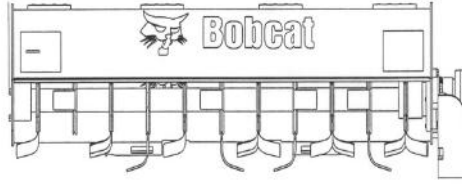

(MT50, MT52, MT55, MT85) (S70, S100) (T110)

7196028	40" Tiller	\$4,272.00	24.0%	\$0.00	\$3,246.72
---------	------------	------------	-------	--------	------------

Part Number	Trencher Description	SLP in US\$	Discount Percent	Labor	Price
-------------	----------------------	-------------	------------------	-------	-------

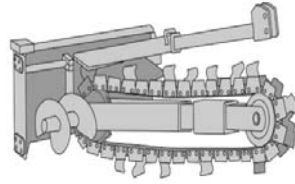

Part Number	LT112 Trencher Description	SLP in US\$	Discount Percent	Labor	Price
-------------	----------------------------	-------------	------------------	-------	-------

(MT50, MT52, MT55, MT85) (S70)

M7011	LT112 Trencher	\$3,659.00	24.0%	\$0.00	\$2,780.84
-------	----------------	------------	-------	--------	------------

(Includes mounting frame, hoses, couplers, 2' depth, manual sideshift, 4" trench cleaner)
 (Can only order one factory installed chain option per trencher model)

2' Chain Options are 1.654" Double Standard (DS) Anti-Back Flex (ABF)

M7011-R01-C02	2' x 4" cup teeth, Single Standard pattern	\$481.00	24.0%	\$0.00	\$365.56
M7011-R01-C01	2' x 4" Cup Teeth, Double Standard Pattern	\$587.00	24.0%	\$0.00	\$446.12
M7011-R01-C03	2' x 4" cup & carbide teeth, Double Standard pattern	\$1,073.00	24.0%	\$0.00	\$815.48
M7011-R01-C05	2' x 4" Shark/Cup teeth, Double Standard pattern	\$713.00	24.0%	\$0.00	\$541.88
M7011-R01-C06	2' x 6" Shark/Cup teeth, Double Standard pattern	\$898.00	24.0%	\$0.00	\$682.48

Part	LT113 Trencher	SLP in US\$	Discount	Labor	Price
------	----------------	-------------	----------	-------	-------

Number	Description		Percent		
(MT50, MT52, MT55, MT85) (S70)					
M7014	LT113 Trencher - BOBTACH Mounted	\$3,893.00	24.0%	\$0.00	\$2,958.68
	(Includes mounting frame, hoses, couplers, 3' depth, manual sideshift, 4" trench cleaner)				
	(Can only order one factory installed chain option per trencher model)				
M7014-R01-C02	3' x 4" Cup Teeth, Single Standard Pattern	\$465.00	24.0%	\$0.00	\$353.40
M7014-R01-C04	3' x 6" Cup Teeth, Single Standard Pattern	\$496.00	24.0%	\$0.00	\$376.96
M7014-R01-C01	3' x 4" Cup Teeth, Double Standard Pattern	\$529.00	24.0%	\$0.00	\$402.04
M7014-R01-C03	3' x 4" Cup & Carbide Teeth, Double Standard Pattern	\$1,083.00	24.0%	\$0.00	\$823.08
M7014-R01-C06	3' x 4" Shark/Cup Teeth, Double Standard Pattern	\$872.00	24.0%	\$0.00	\$662.72
M7014-R01-C07	3' x 6" Shark/Cup Teeth, Double Standard Pattern	\$1,088.00	24.0%	\$0.00	\$826.88
(MT85)					
M7040	LT113 Trencher - Common Industry Interface	\$3,893.00	24.0%	\$0.00	\$2,958.68
	(Includes mounting frame, hoses, couplers, 3' depth, manual sideshift, 4" trench cleaner)				
	(Can only order one factory installed chain option per trencher model)				
	3' Chain Options are 1.654" Double Standard (DS) Anti-Back Flex (ABF)				
M7040-R01-C02	3' x 4" Cup Teeth, Single Standard Pattern	\$465.00	24.0%	\$0.00	\$353.40
M7040-R01-C04	3' x 6" Cup Teeth, Single Standard Pattern	\$496.00	24.0%	\$0.00	\$376.96
M7040-R01-C01	3' x 4" Cup Teeth, Double Standard Pattern	\$529.00	24.0%	\$0.00	\$402.04
M7040-R01-C03	3' x 4" Cup & Carbide Teeth, Double Standard Pattern	\$1,083.00	24.0%	\$0.00	\$823.08
M7040-R01-C06	3' x 4" Shark/Cup Teeth, Double Standard Pattern	\$872.00	24.0%	\$0.00	\$662.72
M7040-R01-C07	3' x 6" Shark/Cup Teeth, Double Standard Pattern	\$1,088.00	24.0%	\$0.00	\$826.88

Part Number	Vibratory Plow Description	SLP in US\$	Discount Percent	Labor	Price
-------------	----------------------------	-------------	------------------	-------	-------

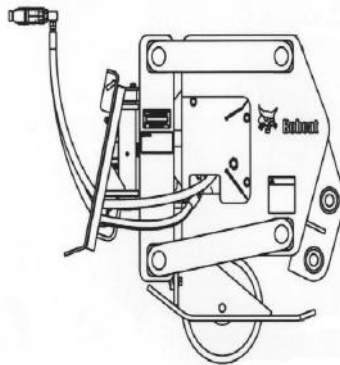

(MT52, MT55, MT85)					
7100484	VP12 Vibratory Plow	\$8,677.00	24.0%	\$0.00	\$6,594.52
	(Includes blade mounting pins) (Must also order blade)				
7100491	3/8" Blade, 6-12" depth with 1" Clevis	\$206.00	24.0%	\$0.00	\$156.56
7100493	3/8" Blade, 12-18" depth with 1" Clevis	\$222.00	24.0%	\$0.00	\$168.72
	(Recommended for soft/loose soils only)				
7100495	1/2" Chute Blade, 6-12" depth	\$349.00	24.0%	\$0.00	\$265.24
7100497	1/2" Chute Blade, 12-18" depth	\$375.00	24.0%	\$0.00	\$285.00
	(Recommended for soft/loose soils only)				



Part Number	5600 G-Series Description	SLP in US\$	Discount Percent	Labor Charges	Price
M1221	5600 Turbo Utility Work Machine (Tier 4)	\$53,404.00	20.0%	\$ -	\$42,723.20



Part Number	Factory Installed Options Description	SLP in US\$	Discount Percent	PDI & Delivery:	Price
<i>Individual Options</i>					
M1221-R08-C02	Attachment Control, 7 Pin	\$236.00	20.0%	\$ -	\$188.80
M1221-R02-C03	Cab Enclosure with Heater & Air Conditioning Includes doors, floor mats, cab foam, heater and air conditioning unit, three-piece headliner with radio pocket, location for speakers, and storage behind seats for a clip board, owner's manual, etc.	\$4,864.00	20.0%	\$ -	\$3,891.20
M1221-P01-C01	Deluxe Road Package Must also order Cab Enclosure with Heater and Air Conditioning; Includes back-up alarm, turn signals, flashers, tail lights, brake lights, rear view mirror, side mirrors, horn, rear work light, and headlights Allows Work Machine to meet most regulations for driving on local roadways. Check with local DMV to confirm all requirements for off-highway machinery on your local roads. Toolcat machines are not "automobiles" and thus do not need to be licensed to drive on local roads, but usually require lighting and mirrors included in this package .	\$2,322.00	20.0%	\$ -	\$1,857.60
M1221-R07-C02	Heavy Duty Battery	\$97.00	20.0%	\$ -	\$77.60
M1221-R03-C02	High Flow Package Includes high flow valve, larger auxiliary hoses, and high flow switch in cab; Provides 27.9 GPM for attachment operation; Must also order 7-Pin Attachment Control	\$1,736.00	20.0%	\$ -	\$1,388.80
M1221-A01-C05	Interior Trim Insulation for left and right side panels of center console	\$205.00	20.0%	\$ -	\$164.00
M1221-R06-C02	Keyless Ignition System	\$336.00	20.0%	\$ -	\$268.80
M1221-R12-C02	Power Bobtach	\$1,099.00	20.0%	\$ -	\$879.20
M1221-R15-C02	Radio Features Aux mini jack for MP-3, Weatherproof design, NOAA Weatherband, 6 AM and 5 FM Presets Time and Date, Job Clock, Backlit Display, 3.5 mm headphone jack, 12 volt DC Power Outlet.	\$533.00	20.0%	\$ -	\$426.40
M1221-R16-C02	Traction Control Senses wheel speed variation during limited traction. Applies braking to increase torque to wheels in traction. Includes switch in cab for system deactivation	\$545.00	20.0%	\$ -	\$436.00

Part Number	Factory Installed Tire Options Description	SLP in US\$	Discount Percent	PDI & Delivery:	Price
<i>Set of 4 Tires- In Place of Base Equipment</i>					
M1221-R05-C04	29 x 10.5, 8 PR, Trac Tires Work Machine Width - 60"	\$546.00	20.0%	\$ -	\$436.80
M1221-R05-C05	29 x 12.5, 6 PR, Turf Tires Work Machine Width - 64"; Includes wide fenders	\$786.00	20.0%	\$ -	\$628.80

Part Number	5610 G-Series Description	SLP in US\$	Discount Percent	PDI & Delivery:	Price
M1223	5610 Turbo Utility Work Machine - Deluxe Version (Tier 4)	\$67,554.00	20.0%	\$ -	\$54,043.20



Part Number	Factory Installed Tire Options Description	SLP in US\$	Discount Percent	Price
<i>Set of 4 Tires- In Place of Base Equipment</i>				
M1223-R05-C04	29 x 10.5, 8 PR, Trac Tires Work Machine Width - 60"	\$546.00	20.0%	\$436.80
M1223-R05-C05	29 x 12.5, 6 PR, Turf Tires Work Machine Width - 64"; Includes wide fenders	\$786.00	20.0%	\$628.80



Part Number	Angle Brooms Description	SLP in US\$	Discount Percent	Labor	Price
-------------	--------------------------	-------------	------------------	-------	-------

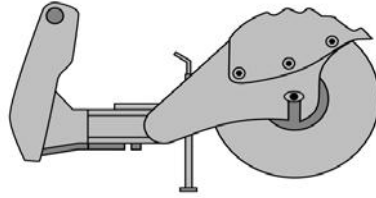

(5600, 5610) 6905805	68" Angle Broom (Work Machine must be equipped with a 7-Pin Attachment Control Kit) (A 14-Pin T-Harness Kit is required when used on work machine equipped with a 14-Pin Attachment Control Kit)	\$5,613.00	24.0%	\$0.00	\$4,265.88
-------------------------	---	------------	-------	--------	------------

(5600, 5600H, 5610, 5610H) 6905806	84" Angle Broom (Work Machine must be equipped with a 7-Pin Attachment Control Kit) (A 14-Pin T-Harness Kit is required when used on work machine equipped with a 14-Pin Attachment Control Kit)	\$6,114.00	24.0%	\$0.00	\$4,646.64
---------------------------------------	---	------------	-------	--------	------------

Part Number	Augers Description	SLP in US\$	Discount Percent	Labor	Price
-------------	--------------------	-------------	------------------	-------	-------

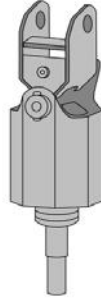

(5600, 5610) 6809442	Model 15C Auger Drive Unit (Must also order Mounting Frame and Bit) (Auger drive unit is shipped with a 7/8" round bit retention pin, if used in conjunction with a hex bit a 5/8" Pin Kit P/N 6809733 is required.)	\$1,781.00	24.0%	\$0.00	\$1,353.56
7145345	Model 15H Hex Shaft Auger Drive Unit (Must also order Mounting Frame and Bit)	\$1,781.00	24.0%	\$0.00	\$1,353.56
(5600H, 5610H) 6809445	Model 30C Auger Drive Unit (Must also order Mounting Frame and Bit) (Auger drive unit is shipped with a 7/8" round bit retention pin, if used in conjunction with a hex bit a 5/8" Pin Kit P/N 6809733 is required.)	\$2,328.00	24.0%	\$0.00	\$1,769.28
7138264	Model 30H Hex Shaft Auger Drive Unit (Must also order Mounting Frame and Bit)	\$2,328.00	24.0%	\$0.00	\$1,769.28
6812980	Mounting Frame, (Includes Mounting Hardware)	\$412.00	24.0%	\$0.00	\$313.12

Auger Drive & Bit Recommendations

Model 10 Augers—Recommended bit size 6, 9", 12", 15", 16", 18"

Model 15C and 30C Augers—Recommended bit size 6", 9", 12", 15", 18", 24", 30", 36"
 Model 15H and 30H Augers—Recommended bit size 6", 9", 12", 15", 18", 24", 30", 36"
 Light Duty, Standard Duty, Heavy Duty and Rock Bits are Available.

Part Number	Box Blade Description	SLP in US\$	Discount Percent	Labor	Price
	See Pallet Forks				

Part Number	Box Blade Description	SLP in US\$	Discount Percent	Labor	Price
-------------	-----------------------	-------------	------------------	-------	-------

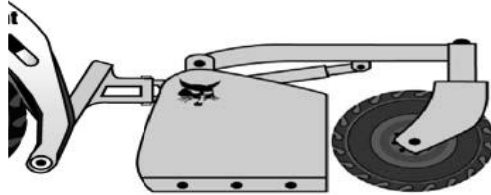

(5600, 5610) 6906574	84" Box Blade (Used for rough grading and landscaping)	\$4,287.00	24.0%	\$0.00	\$3,258.12
-------------------------	--	------------	-------	--------	------------

Part Number	Brushcat Rotary Cutter Description	SLP in US\$	Discount Percent	Labor	Price
-------------	------------------------------------	-------------	------------------	-------	-------

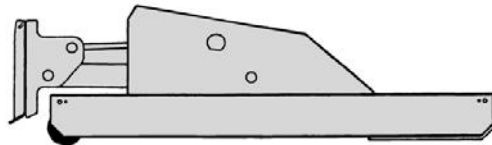

(5600, 5610) 7234049	66" Brushcat Rotary Cutter, Standard Flow (RC66) (Not approved for A-Series or B-Series) (Approved for use with SN A00211001 & above, 5600 SN A00311001 & above, 5600 s/n A0W111001, & above, 5600 SN A94Y11001 & above, 5610 A7Y711001 & above and 5610 SN APFB11001 & above)	\$6,400.00	24.0%	\$0.00	\$4,864.00
-------------------------	--	------------	-------	--------	------------

(5600H, 5610H) 7233014	66" Brushcat Rotary Cutter, High Flow (RC66HF) (Not approved for A-Series or B-Series) (Approved for use with 5600 s/n A00311001 & Above, 5600 s/n A0W111001, 5600 SN A94Y11001 & Above, 5610 SN A7Y711001 & above and 5610, APFB11001 & Above)	\$7,180.00	24.0%	\$0.00	\$5,456.80
---------------------------	---	------------	-------	--------	------------

(5600, 5610) 7218087	72" Brushcat Rotary Cutter, Standard Flow (RC72) (Not approved for A-Series or B-Series) (Approved for use with SN A00211001 & above, 5600 SN A00311001 & above, 5600 s/n A0W111001, & above, 5600 SN A94Y11001 & above, 5610 A7Y711001 & above and 5610 SN APFB11001 & above)	\$6,722.00	24.0%	\$0.00	\$5,108.72
-------------------------	--	------------	-------	--------	------------

(5600H, 5610H) 7233002	72" Brushcat Rotary Cutter, High Flow (RC72HF) (Not approved for A-Series or B-Series) (Approved for use with 5600 s/n A00311001 & Above, 5600 s/n A0W111001, 5600 SN A94Y11001 & Above, 5610 SN A7Y711001 & above and 5610, APFB11001 & Above)	\$7,363.00	24.0%	\$0.00	\$5,595.88
---------------------------	---	------------	-------	--------	------------

Part Number	Buckets Description	SLP in US\$	Discount Percent	Labor	Price
-------------	---------------------	-------------	------------------	-------	-------

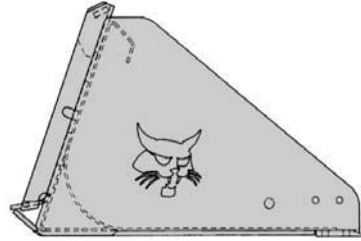

(5600, 5610) 7114585	62" General Purpose Bucket ♦	\$718.00	24.0%	\$0.00	\$545.68
7114586	68" General Purpose Bucket ♦	\$735.00	24.0%	\$0.00	\$558.60
7114587	74" General Purpose Bucket ♦	\$782.00	24.0%	\$0.00	\$594.32
(5600, 5610) 7184103	68" Snow & Light Material Bucket	\$1,182.00	24.0%	\$0.00	\$898.32
7184105	74" Snow & Light Material Bucket	\$1,251.00	24.0%	\$0.00	\$950.76
7184110	80" Snow & Light Material Bucket	\$1,373.00	24.0%	\$0.00	\$1,043.48

(Not approved for A-Series or B-Series) (Approved for use with s/n A00211001 & above, 5600 SN A00311001 & above, 5600 s/n A00311001 & above, 5600 s/n A0W111001 & above, 5600 SN A94Y11001 & above, and 5610 A7Y711001 & above, and 5610, SN APFB11001 & above)

Part Number	Chipper Description	SLP in US\$	Discount Percent	Labor	Price
-------------	---------------------	-------------	------------------	-------	-------

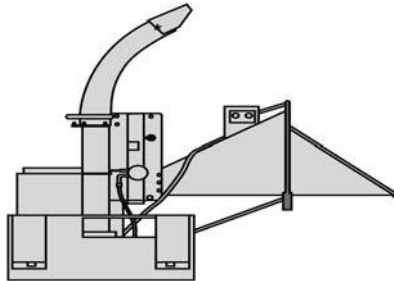

(5600, 5610) 6719129	5A Chipper (Work Machine must be equipped with a 7-Pin Attachment Control Kit) (Work Machines serial number 520512159 and below require version 27 or newer software to be installed on machine.)	\$10,854.00	24.0%	\$0.00	\$8,249.04
(5600H, 5610H) 7117662	8B Chipper (Work machine must be equipped with High Flow and 7-Pin Attachment Control Kit) (Approved for use with 5600 s/n 424711001 & above, 5600, SN A0W111001 and above and and 5610 A7Y&11001 & above, APFB11001 and above)	\$13,657.00	24.0%	\$0.00	\$10,379.32

Part Number	Combination Bucket Description	SLP in US\$	Discount Percent	Labor	Price
-------------	--------------------------------	-------------	------------------	-------	-------



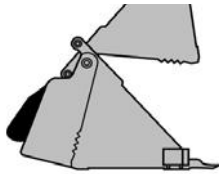

(5600, 5610)
7167310

62" Combination Bucket

(Approved for use with 5600 s/n A00211001 & above, 5600 s/n A00311001 & above,
5600 s/n A0W111001 & above and 5610 A7Y711001 & above)
(Bolt-on Teeth are available)

\$3,210.00 24.0% \$0.00 \$2,439.60

Combination Buckets are not approved for use with the Tilt-Tatch.

Part Number	Dozer Blade Description	SLP in US\$	Discount Percent	Labor	Price
-------------	-------------------------	-------------	------------------	-------	-------

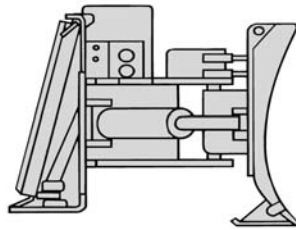

(5600, 5610)
6905884

80" Dozer Blade, 6-WAY

(Work Machine must be equipped with a 7-Pin Attachment Control Kit)
(A 14-Pin T-Harness Kit is required when used on work machine equipped with a
14-Pin Attachment Control Kit)

\$5,123.00 24.0% \$0.00 \$3,893.48

Part Number	Dumping Hopper Description	SLP in US\$	Discount Percent	Labor	Price
-------------	----------------------------	-------------	------------------	-------	-------

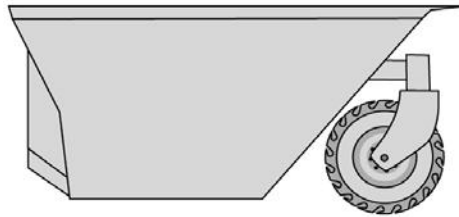

(5600, 5610)
6727275

Model 10 Dumping Hopper

(Approved for use with 5600 s/n A00211001 & above, 5600 s/n A00311001 & above,
5600 s/n A0W111001 & above, and 5610 A7Y711001)
(Must also order mounting frame bracket p/n 6729483)
(Includes 8.5 x 12 Bobcat Heavy Duty Tire. Tire is not installed on Dumping Hopper.)

\$3,148.00 24.0% \$0.00 \$2,392.48

Part Number	Flail Cutter Description	SLP in US\$	Discount Percent	Labor	Price
-------------	--------------------------	-------------	------------------	-------	-------



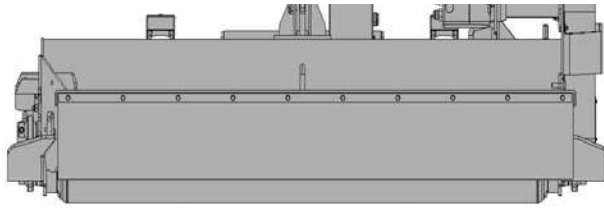

(5600, 5600H, 5610, 5610H)

7101894 FC200 Flail Cutter \$12,686.00 24.0% \$0.00 \$9,641.36

Part Number	Grader Description	SLP in US\$	Discount Percent	Labor	Price
-------------	--------------------	-------------	------------------	-------	-------

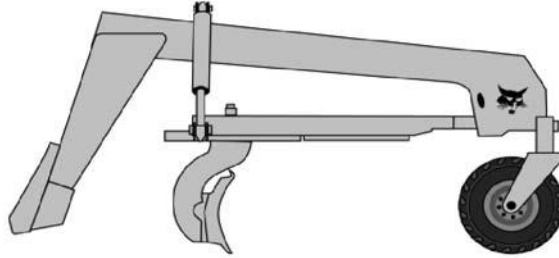

(5600, 5610)

6906480 Grader \$9,623.00 24.0% \$0.00 \$7,313.48

(Work Machine must be equipped with a 7-Pin Attachment Control Kit)

(A 14-Pin T-Harness Kit is required when used on work machine equipped with a 14-Pin Attachment Control Kit)

Part Number	Grapple, Industrial Description	SLP in US\$	Discount Percent	Labor	Price
-------------	---------------------------------	-------------	------------------	-------	-------

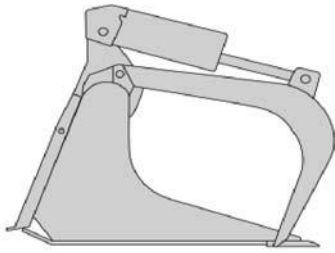

Industrial Bucket Grapple

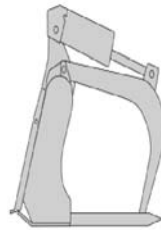

Industrial Fork Grapple

(5600, 5610)

7168342 62" Industrial Bucket Grapple \$3,463.00 24.0% \$0.00 \$2,631.88

(Bolt-On Cutting Edge included)

7168340 68" Industrial Bucket Grapple \$3,601.00 24.0% \$0.00 \$2,736.76

(Bolt-On Cutting Edge included)

7168344 66" Industrial Fork Grapple, with 7 teeth \$4,162.00 24.0% \$0.00 \$3,163.12

Part Number	Grapple, Utility Description	SLP in US\$	Discount Percent	Labor	Price
-------------	------------------------------	-------------	------------------	-------	-------

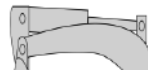
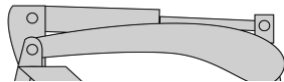

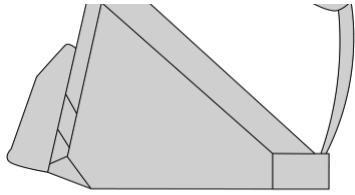

Farm Grapple with Bucket

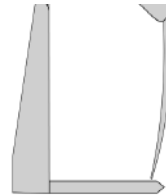

Farm Grapple with Forks

(5600, 5610)
7176977

Grapple, 55" Utility – C/I

(Fits 60 – 72" Utility Forks)

(Must also order Grapple stop kit, p/n 7120201 or 6818369)

(Price includes \$270 for installation)

\$1,635.00 24.0% \$270.00 \$1,512.60

(5600, 5610)
7176783

Grapple, 55" Utility - GP

(Fits 62", 68" and 74" **General Purpose** buckets)

(Must also order Grapple stop kit, p/n 7120201 or 6818369)

(Price includes \$270 for installation)

\$1,615.00 24.0% \$270.00 \$1,497.40

Part Number	Landplane Description	SLP in US\$	Discount Percent	Labor	Price
-------------	-----------------------	-------------	------------------	-------	-------

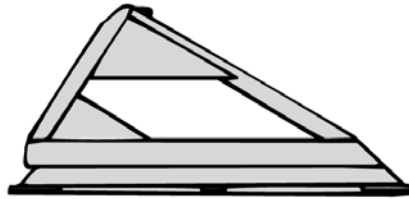

(5600, 5610)
6906150

72" Deluxe Landplane Leveling Attachment

(Includes expanded metal grate, scarifier assembly, teeth and respective hardware)

\$2,223.00 24.0% \$0.00 \$1,689.48

Part Number	Landscape Rake Description	SLP in US\$	Discount Percent	Labor	Price
-------------	----------------------------	-------------	------------------	-------	-------

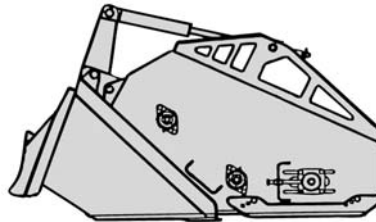

(5600, 5610)
6709107

5B Landscape Rake

(Not approved for A-Series or B-Series)

(Approved for use with 5600 s/n A00211001 & above, 5600 s/n A00311001 & above,

5600 s/n A0W111001 & above and 5610 A7Y711001 & above)

\$7,757.00 24.0% \$0.00 \$5,895.32

Part Number	Mower, Finish Description	SLP in US\$	Discount Percent	Labor	Price
-------------	---------------------------	-------------	------------------	-------	-------

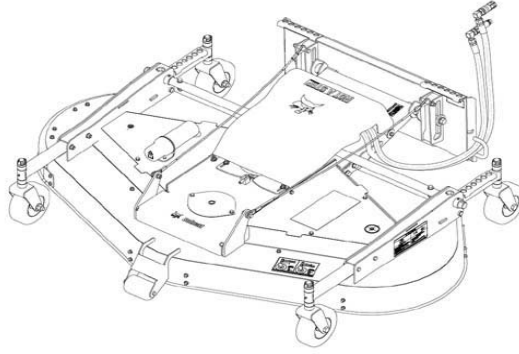

(5600, 5610)						
7144850	72" Mower	\$5,680.00	24.0%	\$0.00	\$4,316.80	
(5600, 5610)						
7143993	90" Mower	\$6,215.00	24.0%	\$0.00	\$4,723.40	

Part Number	Pallet Forks, Hydraulic Description	SLP in USS	Discount Percent	Labor	Price
-------------	-------------------------------------	------------	------------------	-------	-------

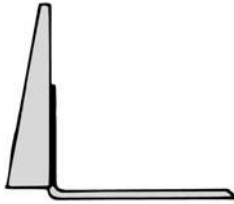

(5600, 5610)						
6905425	48" Hydraulic Pallet Fork (Includes back frame and 2 hydraulically adjustable 48" teeth)	\$3,014.00	24.0%	\$0.00	\$2,290.64	

Part Number	Pallet Forks Description	SLP in USS	Discount Percent	Labor	Price
-------------	--------------------------	------------	------------------	-------	-------

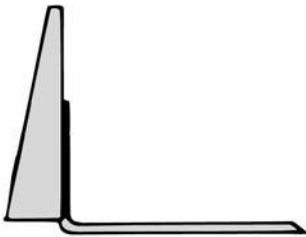

Standard Pallet Fork Teeth and Frame

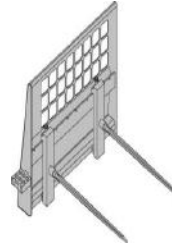

Bale Forks and Frame

(5600, 5610)						
6712927	Pallet Fork Frame, less teeth	\$437.00	24.0%	\$0.00	\$332.12	
	<u>Bale Forks</u>					
6815781	Bale Forks, Set of 2	\$682.00	24.0%	\$0.00	\$518.32	
	<u>Pallet fork Teeth</u>					
6540184	36" Pallet fork Teeth, set of 2	\$274.00	24.0%	\$0.00	\$208.24	
6540183	42" Pallet fork Teeth, set of 2	\$292.00	24.0%	\$0.00	\$221.92	
6540182	48" Pallet fork Teeth, set of 2	\$299.00	24.0%	\$0.00	\$227.24	

Part Number	Rock Bucket Description	SLP in US\$	Discount Percent	Labor	Price
-------------	-------------------------	-------------	------------------	-------	-------



(5600, 5610) 7185941	62" Rock Bucket	\$1,490.00	24.0%	\$0.00	\$1,132.40
(5600, 5610) 7185943	68" Rock Bucket	\$1,558.00	24.0%	\$0.00	\$1,184.08

Part Number	Sand/Salt Spreader Description	SLP in US\$	Discount Percent	Labor	Price
-------------	--------------------------------	-------------	------------------	-------	-------

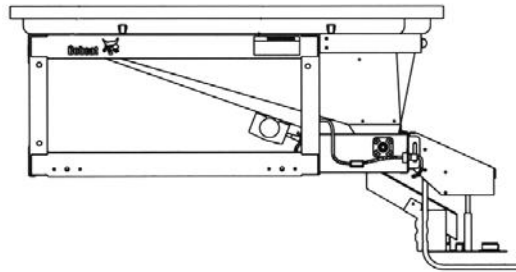

(5600) 7101567	Sand/Salt Spreader (Includes controller, wire harness, vibrator and all necessary mounting hardware) (Price includes \$450 for installation)	\$4,932.00	24.0%	\$450.00	\$4,198.32
-------------------	--	------------	-------	----------	------------

Part Number	Scraper Description	SLP in US\$	Discount Percent	Labor	Price
-------------	---------------------	-------------	------------------	-------	-------

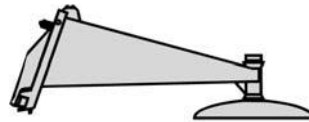

(5600, 5610) 6675211	Scraper	\$1,194.00	24.0%	\$0.00	\$907.44
-------------------------	---------	------------	-------	--------	----------

Part Number	Seeder Description	SLP in US\$	Discount Percent	Labor	Price
-------------	--------------------	-------------	------------------	-------	-------

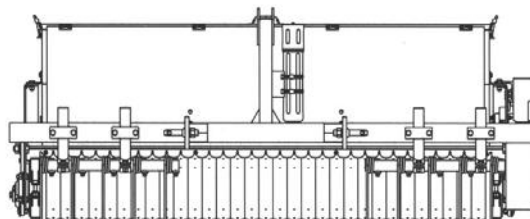



(5600, 5610)

7167712	Seeder, 72", 3PT Mounting (Must also order Bob-Tach adapter if used on front of Work Machine equipped with a Bob-Tach)	\$7,096.00	24.0%	\$0.00	\$5,392.96
---------	--	------------	-------	--------	------------

Part Number	Factory Installed Options - Seeder Description	SLP in US\$	Discount Percent	Labor	Price
-------------	--	-------------	------------------	-------	-------

7167758	Bob-Tach Adapter (Allows Seeder to mount on Bob-Tach equipped machines)	\$702.00	24.0%	\$0.00	\$533.52
---------	---	----------	-------	--------	----------

Part Number	Snow Blade Description	SLP in US\$	Discount Percent	Labor	Price
-------------	------------------------	-------------	------------------	-------	-------

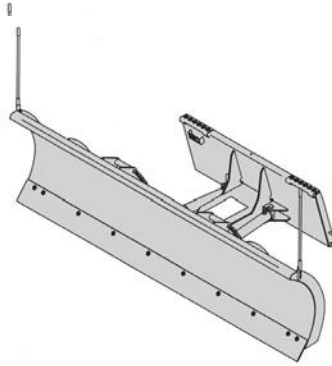

(5600, 5610) 6905156	72" Snow Blade (with hydraulic angle)	\$2,365.00	24.0%	\$0.00	\$1,797.40
-------------------------	---------------------------------------	------------	-------	--------	------------

(5600, 5610) 6716836	84" Snow Blade (with hydraulic angle)	\$2,524.00	24.0%	\$0.00	\$1,918.24
-------------------------	---------------------------------------	------------	-------	--------	------------

(5600, 5610) 6716838	96" Snow Blade (with hydraulic angle)	\$2,735.00	24.0%	\$0.00	\$2,078.60
-------------------------	---------------------------------------	------------	-------	--------	------------

(5600, 5610) 7207861	86" Snow Blade – Heavy Duty (with hydraulic angle)	\$3,923.00	24.0%	\$0.00	\$2,981.48
-------------------------	--	------------	-------	--------	------------

(5600, 5610) 7207862	96" Snow Blade – Heavy Duty (with hydraulic angle)	\$4,156.00	24.0%	\$0.00	\$3,158.56
-------------------------	--	------------	-------	--------	------------

Part Number	Snow Pusher Description	SLP in US\$	Discount Percent	Labor	Price
-------------	-------------------------	-------------	------------------	-------	-------

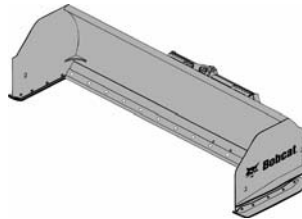

(5600, 5610) 7113767	Snow Pusher, 8'	\$3,269.00	24.0%	\$0.00	\$2,484.44
-------------------------	-----------------	------------	-------	--------	------------

Part Number	Snow V-Blade Description	SLP in US\$	Discount Percent	Labor	Price
-------------	--------------------------	-------------	------------------	-------	-------



Blade in "V" Configuration

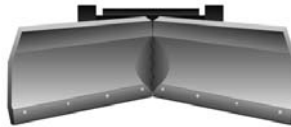

Blade in "Scoop" Configuration

Blade in "Angled" Configuration

(5600, 5610)
7104861

60" Snow V-Blade

(Work Machine must be equipped with a 7-Pin Attachment Control Kit)
Blade is equipped with fingertip 7-Pin Control. Adjustable blade width from 53-60 inches.

\$4,172.00 24.0% \$0.00 \$3,170.72

(5600, 5610)
6958576

72" Snow V-Blade

(Work Machine must be equipped with a 7-Pin Attachment Control Kit)
(A 14-Pin T-Harness Kit is required when used on work machine equipped with a 14-Pin Attachment Control Kit)

\$4,383.00 24.0% \$0.00 \$3,331.08

(5600, 5610)
6958577

84" Snow V-Blade

(Work Machine must be equipped with a 7-Pin Attachment Control Kit)
(A 14-Pin T-Harness Kit is required when used on work machine equipped with a 14-Pin Attachment Control Kit)

\$4,594.00 24.0% \$0.00 \$3,491.44

(5600, 5610)
6958578

96" Snow V-Blade

(Work Machine must be equipped with a 7-Pin Attachment Control Kit)
(A 14-Pin T-Harness Kit is required when used on work machine equipped with a 14-Pin Attachment Control Kit)

\$4,805.00 24.0% \$0.00 \$3,651.80

Part Number	Snowblower Description	SLP in US\$	Discount Percent	Labor	Price
-------------	------------------------	-------------	------------------	-------	-------

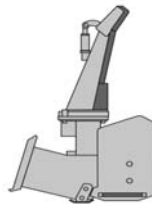

Must order a hydraulic motor package with the SB200 & SB240 Snowblowers
Work Machine must be equipped with a 7-pin Attachment Control Kit.

(5600, 5600H, 5610, 5610H)

M7001 SB200 x 60" Snowblower \$4,692.00 24.0% \$0.00 \$3,565.92

M7001-R01-C02 6.2 Hydraulic Motor Package **\$1,125.00 24.0% \$0.00 \$855.00**
(5600H, 5610H)

M7001-R01-C04 9.6 Hydraulic Motor Package **\$1,257.00 24.0% \$0.00 \$955.32**
(5600H, 5610H)

(5600, 5600H, 5610, 5610H)

M7002 SB200 x 66" Snowblower \$4,839.00 24.0% \$0.00 \$3,677.64

M7002-R01-C02 6.2 Hydraulic Motor Package **\$1,125.00 24.0% \$0.00 \$855.00**
(5600H, 5610H)

M7002-R01-C04	9.6 Hydraulic Motor Package (5600H, 5610H)	\$1,257.00	24.0%	\$0.00	\$955.32
(5600, 5600H, 5610, 5610H)					
M7003	SB200 x 72" Snowblower	\$4,998.00	24.0%	\$0.00	\$3,798.48
M7003-R01-C02	6.2 Hydraulic Motor Package (5600H, 5610H)	\$1,125.00	24.0%	\$0.00	\$855.00
M7003-R01-C04	9.6 Hydraulic Motor Package (5600H, 5610H)	\$1,257.00	24.0%	\$0.00	\$955.32

Part Number	SB240 Snowblower Description	SLP in US\$	Discount Percent	Labor	Price
-------------	---------------------------------	-------------	------------------	-------	-------

*Must order a hydraulic motor package with the SB200 & SB240 Snowblowers
Work Machine must be equipped with a 7-pin Attachment Control Kit.*

(5600H, 5610H)					
M7005	SB240 x 72" Snowblower	\$6,472.00	24.0%	\$0.00	\$4,918.72
M7005-R01-C04	9.6 Hydraulic Motor Package (5600H, 5610H)	\$1,257.00	24.0%	\$0.00	\$955.32

Part Number	Accessories Description	SLP in US\$	Discount Percent	Labor	Price
-------------	----------------------------	-------------	------------------	-------	-------

6958978	Truck Loading Chute (For SB240 Snowblowers, will not fit SB200) (For use with high flow work machine only) (Includes deflector control, support mount and hoses) (Price includes \$270 for installation)	\$1,622.00	24.0%	\$270.00	\$1,502.72
---------	---	------------	-------	----------	------------

Part Number	Sod Layer Description	SLP in US\$	Discount Percent	Labor	Price
-------------	--------------------------	-------------	------------------	-------	-------

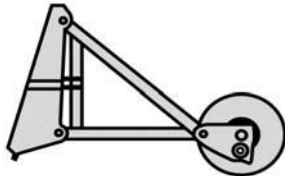

(5600, 5610)					
6906783	Sod Layer (Not approved for A-Series or B-Series) (Approved for use with 5600 s/n A00211001 & above, 5600 s/n A00311001 & above, 5600 s/n A0W111001 & above and 5610 A7Y711001 & above)	\$3,928.00	24.0%	\$0.00	\$2,985.28

Part Number	Soil Conditioner Description	SLP in US\$	Discount Percent	Labor	Price
-------------	---------------------------------	-------------	------------------	-------	-------

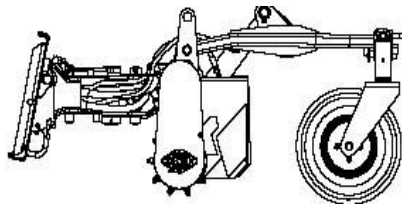

(5600, 5600H, 5610, 5610H)					
6906513	72" Soil Conditioner, Manual Angle	\$8,614.00	24.0%	\$0.00	\$6,546.64

7135945	72" Soil Conditioner, Hydraulic Angle and Depth (Loader must be equipped with an Attachment Control Kit)	\$9,360.00	24.0%	\$0.00	\$7,113.60
7135946	84" Soil Conditioner, Hydraulic Angle (Loader must be equipped with an Attachment Control Kit)	\$9,899.00	24.0%	\$0.00	\$7,523.24
(5600H, 5610H)					
7135944	72" Soil Conditioner, High Flow Hydraulic Angle and Depth (Loader must be equipped with an Attachment Control Kit)	\$9,684.00	24.0%	\$0.00	\$7,359.84
7135947	84" Soil Conditioner, High Flow Hydraulic Angle and Depth (Loader must be equipped with an Attachment Control Kit)	\$10,330.00	24.0%	\$0.00	\$7,850.80

Part Number	Spreader Description	SLP in US\$	Discount Percent	Labor	Price
-------------	----------------------	-------------	------------------	-------	-------

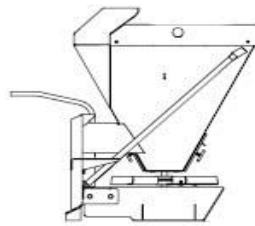

(5600, 5610)					
7157284	HS8 Spreader	\$3,628.00	24.0%	\$0.00	\$2,757.28

Part Number	Stump Grinder Description	SLP in US\$	Discount Percent	Labor	Price
-------------	---------------------------	-------------	------------------	-------	-------

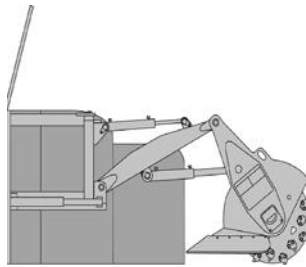

(5600, 5600H, 5610, 5610H)					
6808034	SG60 Stump Grinder (Work Machine must be equipped with a 7-Pin Attachment Control Kit) (A 14-Pin T-Harness Kit is required when used on work machine equipped with a 14-Pin Attachment Control Kit)	\$9,292.00	24.0%	\$0.00	\$7,061.92

Part Number	Sweeper Description	SLP in US\$	Discount Percent	Labor	Price
-------------	---------------------	-------------	------------------	-------	-------

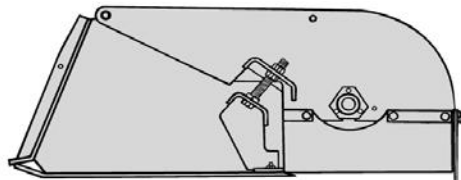

(5600, 5610)					
7138870	54" Sweeper	\$3,697.00	24.0%	\$0.00	\$2,809.72

(Not approved for A-Series or B-Series) (Approved for use with 5600 s/n A00211001 &

above, 5600 s/n A00311001 & above, 5600 s/n A0W111001 & above, and
5610 A7Y711001 & above)

(5600, 5610)
6707144

60" Sweeper

\$4,012.00

24.0%

\$0.00

\$3,049.12

(Not approved for A-Series or B-Series) (Approved for use with 5600 s/n A00211001
& above, 5600 s/n A00311001 & above, 5600 s/n A0W111001 & above, and
610 A7Y711001 & above)

Part Number	Accessories Description	SLP in US\$	Discount Percent	Labor	Price
6714219	Gutter Brush (Add-on for 60" Sweeper) (Includes hoses, couplers, steel bristles, mounting frame, hardware and control valve) (Price includes \$270 for installation)	\$1,416.00	24.0%	\$270.00	\$1,346.16

Part Number	Three Point Hitch Adapter Description	SLP in US\$	Discount Percent	Labor	Price
-------------	---------------------------------------	-------------	------------------	-------	-------



Category I and II Hitch

(5600, 5610)
7110394

THREE-POINT HITCH ADAPTER, CATEGORY "I AND II"

\$971.00

24.0%

\$270.00

\$1,007.96

(Quick-tach connection to Three-Point Hitch implements to convert to Bob-Tach™)
(Includes 2" receiver for moving trailers)

Part Number	Tiller Description	SLP in US\$	Discount Percent	Labor	Price
-------------	--------------------	-------------	------------------	-------	-------

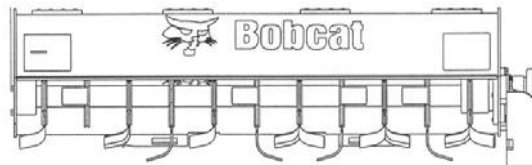

(5600, 5600H, 5610, 5610H)

7104371

62" Rotary Tiller

\$4,899.00

24.0%

\$0.00

\$3,723.24

(5600*, 5600H, 5610, 5610H)

7102125

76" Rotary Tiller

\$5,956.00

24.0%

\$0.00

\$4,526.56

(*Not approved on A-Series 5600, s/n prefix 5205))

Part Number	Tilt Tach Description	SLP in US\$	Discount Percent	Labor	Price
-------------	-----------------------	-------------	------------------	-------	-------

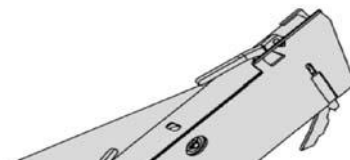

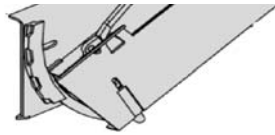

(5600, 5610)
7101600

Tilt-Tatch

(Interface between the work machine's Bob-Tach and non-hydraulic attachments)

\$2,461.00 24.0% \$0.00 \$1,870.36

Use of Tilt-Tatch will reduce Operating Capacity and Tip Load by approximately 20%.
See the Tilt-Tatch Operator's Manual for New Load Ratings.
Tilt-Tatch can be used with non-hydraulic attachments only.

Part Number	Trencher Description	SLP in US\$	Discount Percent	Labor	Price
-------------	----------------------	-------------	------------------	-------	-------

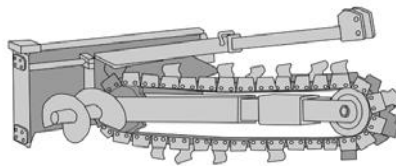

(5600, 5610)
M7013

LT213 Trencher

(Includes 3' depth, manual sideshift, trench cleaner)
(Can only order one chain option per trencher model)

\$3,918.00 24.0% \$0.00 \$2,977.68

Chains are 1.654" Double Standard (DS) Anti-Back Flex (ABF)

M7013-R01-C02
M7013-R01-C04
M7013-R01-C01
M7013-R01-C03
M7013-R01-C06
M7013-R01-C07

3' x 4" Cup Teeth, Single Standard Pattern
3' x 6" Cup Teeth, Single Standard Pattern
3' x 4" Cup Teeth, Double Standard Pattern
3' x 4" Cup & Carbide Teeth, Double Standard Pattern
3' x 4" Shark/Carbide Teeth, Double Standard Pattern
3' x 6" Shark/Carbide Teeth, Double Standard Pattern

\$465.00 24.0% \$0.00 \$353.40
\$496.00 24.0% \$0.00 \$376.96
\$529.00 24.0% \$0.00 \$402.04
\$1,083.00 24.0% \$0.00 \$823.08
\$872.00 24.0% \$0.00 \$662.72
\$1,014.00 24.0% \$0.00 \$770.64

Part Number	Utility Forks Description	SLP in US\$	Discount Percent	Labor	Price
-------------	---------------------------	-------------	------------------	-------	-------

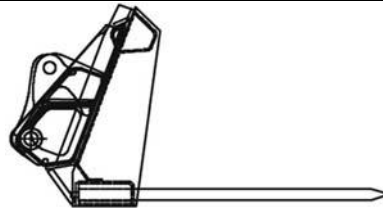

(5600, 5610)
6725178

60" Utility fork, with 8 Teeth

(Use with Farm/Utility grapple P/N 7102176)

\$1,114.00 24.0% \$0.00 \$846.64

(5600, 5610)
6725179

66" Utility fork, with 9 Teeth

(Use with Farm/Utility grapple P/N 7102176)

\$1,304.00 24.0% \$0.00 \$991.04

(5600, 5610)
6725180

72" Utility fork, with 10 Teeth

(Use with Farm/Utility grapple P/N 7102176)

\$1,373.00 24.0% \$0.00 \$1,043.48



Part Number	Compact Utility Tractor Description	SLP in US\$	Discount Percent	Price
-------------	-------------------------------------	-------------	------------------	-------



M1601	CT1021HST COMPACT UTILITY TRACTOR	\$11,527.00	20.0%	\$9,221.60
M1602	CT1025HST COMPACT UTILITY TRACTOR	\$13,922.00	20.0%	\$11,137.60

Part Number	Factory Installed Options Description	SLP in US\$	Discount Percent	Price
-------------	---------------------------------------	-------------	------------------	-------

(Set of 4 Tires- In Place of Base Equipment)

M___-R02-C01	Bobcat Ag: 18 x 8.5 -10, Front; 26 x 12 -12, Rear	\$115.00	20.0%	\$92.00
M___-R02-C03	Bobcat Turf: 18 x 8.5 -10, Front; 26 x 12 -12, Rear	\$44.00	20.0%	\$35.20

Front End Loader - Bob-Tach

Includes quick attach front-end loader, hose kit, bucket level indicator, grill guard, mounting kit, joystick an valve Bob-Tach and 48" Bob-Tach bucket. (For maximum lift capacity, equip with rear ballast box)

M___-A01-C02	FL6 FACTORY INSTALLED (Includes Freight and Assembly charges) (Front end loader is factory installed)	\$3,530.00	20.0%	\$2,824.00
--------------	--	------------	-------	------------

Part Number	COMPACT TRACTOR Description	SLP in US\$	Discount Percent	Price
-------------	-----------------------------	-------------	------------------	-------



M1603	CT2025HST COMPACT TRACTOR	\$16,560.00	20.0%	\$13,248.00
M1604	CT2025MST COMPACT TRACTOR	\$15,284.00	20.0%	\$12,227.20
M1605	CT2035HST COMPACT TRACTOR	\$20,797.00	20.0%	\$16,637.60
M1606	CT2035MST COMPACT TRACTOR	\$19,485.00	20.0%	\$15,588.00
M1607	CT2040HST COMPACT TRACTOR	\$21,343.00	20.0%	\$17,074.40
M1608	CT2040MST COMPACT TRACTOR	\$20,008.00	20.0%	\$16,006.40

Part Number	Factory Installed Options Description	SLP in US\$	Discount Percent	Price
-------------	---------------------------------------	-------------	------------------	-------

TIRES

(Set of 4 Tires- In Place of Base Equipment)

M___-R02-C01	BOBCAT AG: 7-16 8PR, FRONT; 11.2-24 6PR - REAR	\$125.00	20.0%	\$100.00
M___-R02-C03	BOBCAT TURF: 28 X 8.5 -15 6PR, FRONT; 41 X 14 -20 4PR, REAR	\$66.00	20.0%	\$52.80

Front End Loader - Bob-Tach

Includes quick attach front-end loader, hose kit, bucket level indicator, grill guard, mounting kit, joystick an valve Bob-Tach and 60" Bob-Tach bucket. (For maximum lift capacity, equip with rear ballast box)

M___-A01-C01	FL8 FULLY ASSEMBLED (Includes Freight and Assembly Charges) Front End Loader is Factory Installed	\$5,179.00	20.0%	\$4,143.20
--------------	--	------------	-------	------------

M___-A01-C02	FL8 SEMI-ASSEMBLED (Includes Freight and Handling Charges) Front End Loader Arrives with Tractor and Installed at the delivering dealership. Installation Charges will be applied.	\$4,854.00	20.0%	\$3,883.20
--------------	---	------------	-------	------------

Part Number	Compact Tractor Description	SLP in US\$	Discount Percent	Price
-------------	-----------------------------	-------------	------------------	-------



M1609	CT2535HST COMPACT TRACTOR	\$30,804.00	20.0%	\$24,643.20
M1611	CT2540HST COMPACT TRACTOR	\$32,355.00	20.0%	\$25,884.00

Part Number	Factory Installed Options Description	SLP in US\$	Discount Percent	Price
-------------	---------------------------------------	-------------	------------------	-------

(Set of 4 Tires- In Place of Base Equipment)

M__-R02-C01	BOBCAT AG - 7-16 8PR, FRONT; 11.2-24 6PR-REAR	\$125.00	20.0%	\$100.00
M__-R02-C02	BOBCAT TURF - 28 X 8.5 - 15 6PR, FRONT; 41 X 14-20 4PR, REAR	\$66.00	20.0%	\$52.80

Front End Loader - Bob-Tach

Includes quick attach front-end loader, hose kit, bucket level indicator, grill guard, mounting kit, joystick an valve Bob-Tach and 48" Bob-Tach bucket. (For maximum lift capacity, equip with rear ballast box)

M__-A01-C01	FL8 FULLY ASSEMBLED (Includes Freight and Assembly Charges) Front End Loader is Factory Installed	\$5,179.00	20.0%	\$4,143.20
M__-A01-C02	FL8 SEMI-ASSEMBLED (Includes Freight and Handling Charges) Front End Loader Arrives with Tractor and Installed at the delivering dealership. Installation Charges will be applied.	\$4,854.00	20.0%	\$3,883.20

Part Number	Compact Tractor Description	SLP in US\$	Discount Percent	Price
-------------	-----------------------------	-------------	------------------	-------



M1613	CT4045HST COMPACT TRACTOR	\$26,043.00	20.0%	\$20,834.40
M1614	CT4045SST COMPACT TRACTOR	\$23,884.00	20.0%	\$19,107.20
M1615	CT4050HST COMPACT TRACTOR	\$29,545.00	20.0%	\$23,636.00
M1616	CT4050SST COMPACT TRACTOR	\$25,105.00	20.0%	\$20,084.00
M1617	CT4055SST COMPACT TRACTOR	\$26,327.00	20.0%	\$21,061.60
M1618	CT4058SST COMPACT TRACTOR	\$31,486.00	20.0%	\$25,188.80

Part Number	Factory Installed Options Description	SLP in US\$	Discount Percent	Price
-------------	---------------------------------------	-------------	------------------	-------

TIRES

(Set of 4 Tires- In Place of Base Equipment)

M__-R02-C01	BOBCAT AG: 8-16, FRONT; 13.6 - 24 REAR	\$400.00	20.0%	\$320.00
M__-R02-C02	BOBCAT TURF: 29 X 12.5, FRONT; 21.5L X 16.1, REAR	\$225.00	20.0%	\$180.00

Front End Loader - Bob-Tach

Includes quick attach front-end loader, hose kit, bucket level indicator, grill guard, mounting kit, joystick an valve Bob-Tach and 48" Bob-Tach bucket. (For maximum lift capacity, equip with rear ballast box)

M__-A01-C01	FL9 FULLY ASSEMBLED (Includes Freight and Assembly Charges) Front End Loader is Factory Installed	\$6,704.00	20.0%	\$5,363.20
M__-A01-C02	FL9 SEMI-ASSEMBLED	\$6,329.00	20.0%	\$5,063.20

(Includes Freight and Handling Charges) Front End Loader Arrives with Tractor and Installed at the delivering dealership.
Installation Charges will be applied.

Part Number	Compact Tractor Description	SLP in US\$	Discount Percent	Price
				
M1619	CT5545E-HST COMPACT TRACTOR	\$35,895.00	20.0%	\$28,716.00
M1620	CT5550E-HST COMPACT TRACTOR	\$37,734.00	20.0%	\$30,187.20
M1621	CT5555E-HST COMPACT TRACTOR	\$39,697.00	20.0%	\$31,757.60
M1622	CT5558E-HST COMPACT TRACTOR	\$42,583.00	20.0%	\$34,066.40

Part Number	Factory Installed Options Description	SLP in US\$	Discount Percent	Price
<p><u>TIRES</u> (Set of 4 Tires- In Place of Base Equipment)</p>				
M__-R02-C01	BOBCAT AG: 8-16, FRONT; 13.6 - 24 REAR	\$400.00	20.0%	\$320.00
M__-R02-C03	BOBCAT TURF: 29 X 12.5 - 15, FRONT; 21.5L X 16.1, REAR	\$225.00	20.0%	\$180.00
<p><u>Front End Loader - Bob-Tach</u></p> <p>Includes quick attach front-end loader, hose kit, bucket level indicator, grill guard, mounting kit, joystick an valve Bob-Tach and 48" Bob-Tach bucket. (For maximum lift capacity, equip with rear ballast box)</p>				
M__-A01-C01	FL9-5 FULLY ASSEMBLED FACTORY INSTALLED (Includes Freight and Assembly Charges) Front End Loader is Factory Installed	\$7,239.00	20.0%	\$5,791.20
M__-A01-C02	FL9-5 SEMI-ASSEMBLED DEALER INSTALLED (Includes Freight and Handling Charges) Front End Loader Arrives with Tractor and Installed at the delivering dealership. Installation Charges will be applied.	\$6,914.00	20.0%	\$5,531.20



Part Number	Angle Blade Description	SLP in US\$	Discount percent	Labor	Price
-------------	-------------------------	-------------	------------------	-------	-------

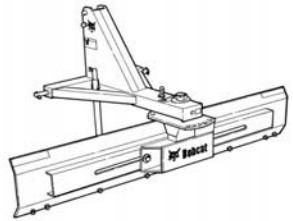

(CT1021, CT1025, CT2025, CT2035, CT2040, CT2535, CT2540) 7365479	3pt. Angle Blade 60", 3AB60 (Price includes \$135 for installation)	\$576.00	24.0%	\$135.00	\$572.76
(CT2035, CT2040, CT2535, CT2540, CT4045, CT4050, CT4055, CT4058, CT5545, CT5550, CT5555, CT5558) 7365493	3pt. Angle Blade 72", 3AB72 (Price includes \$135 for installation)	\$684.00	24.0%	\$135.00	\$654.84
(CT2035, CT2040, CT2535, CT2540, CT4045, CT4050, CT4055, CT4058, CT5545, CT5550, CT5555, CT5558) 7366558	3pt. Angle Blade 84", 3AB84 (Price includes \$135 for installation)	\$756.00	24.0%	\$135.00	\$709.56

Part Number	Auger Description	SLP in US\$	Discount percent	Labor	Price
-------------	-------------------	-------------	------------------	-------	-------



(CT2025, CT2035, CT2040, CT2535, CT2540, CT4045, CT4050, CT4055, CT4058, CT5545, CT5550, CT5555, CT5558) 7365497	3pt. Auger, 3PT (Price includes \$135 for installation)	\$806.00	24.0%	\$135.00	\$747.56
---	---	----------	-------	----------	----------

Auger Bits are extra – Available Bits – 6", 9", 12", 15", 18" and 24"

Part Number	Backhoe Description	SLP in US\$	Discount percent	Labor	Price
-------------	---------------------	-------------	------------------	-------	-------

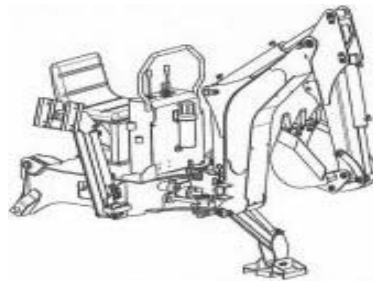

(CT1021, CT1025) 7363011	BH66 (includes mounting kit for CT102X series, reversible seat, hose kit, and 13" Bucket) (Price includes \$370 for installation)	\$6,421.00	24.0%	\$370.00	\$5,249.96
(CT1021, (CT2025, CT2035, CT2040, CT2535, CT2540)CT1025) 7366339	BH76 (includes mounting kit for CT2XXX series, hose kit, and 13" Bucket) (Price includes \$370 for installation)	\$7,018.00	24.0%	\$370.00	\$5,703.68
(CT4045, CT4050, CT4055, CT4058) 7376343	BH86 (includes mounting kit for CT40XX series, hose kit, and 13" Bucket) (Price includes \$370 for installation)	\$7,494.00	24.0%	\$370.00	\$6,065.44
(CT5545, CT5550, CT5555, CT5558) 7375394	BH86 (2)	\$7,494.00	24.0%	\$370.00	\$6,065.44

(includes mounting kit for CT55XX series, hose kit, and 13" Bucket)
 (Price includes \$370 for installation)

Part Number	Box Blade Description	SLP in US\$	Discount percent	Labor	Price
-------------	-----------------------	-------------	------------------	-------	-------

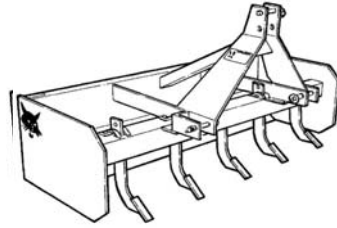

(CT1021, CT1025) 7365520	3pt Box Blade 48", 3BB48 (Price includes \$135 for installation)	\$644.00	24.0%	\$135.00	\$624.44
(CT2025, CT2035, CT2040, CT2535, CT2540, CT4045, CT4050, CT4055, CT4058) 7365525	3pt Box Blade 60", 3BB60 (Price includes \$135 for installation)	\$715.00	24.0%	\$135.00	\$678.40
(CT225, CT230, CT235, CT335, CT440, CT445, CT450) 7365527	3pt Box Blade 72", 3BB72 (Price includes \$135 for installation)	\$884.00	24.0%	\$135.00	\$806.84

Part Number	Finish Mower Description	SLP in US\$	Discount percent	Labor	Price
-------------	--------------------------	-------------	------------------	-------	-------

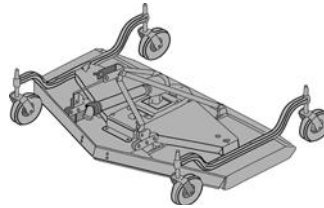

(CT1021, CT1025, CT2025, CT2035, CT2535, CT2540) 7366574	3pt. Mower 60", FM60 (Used with three-point hitch and rear PTO) (Price includes \$225 for installation)	\$2,232.00	24.0%	\$225.00	\$1,921.32
(CT2040, CT2535, CT2540, CT4045, CT4050, CT4055, CT4058, CT5545, CT5550, CT5555, CT5558) 7366578	3pt Mower, FM72 (Used with three-point hitch and rear PTO) (Price includes \$225 for installation)	\$2,412.00	24.0%	\$225.00	\$2,058.12

Part Number	Mower, Mid-Mount Description	SLP in US\$	Discount percent	Labor	Price
-------------	------------------------------	-------------	------------------	-------	-------

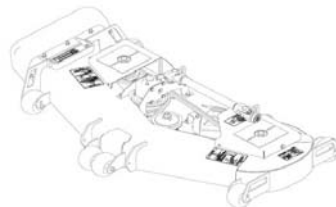

(CT1021, CT1025) 7363024	60" Mid-Mount Mower, M60 (Mounted under center of tractor using mid-PTO) (Must have mid-PTO installed on tractor) (Price includes \$135 for installation)	\$1,845.00	24.0%	\$135.00	\$1,537.20
(CT2025) 7373006	60" Mid-Mount Mower, M60-5 (Mounted under center of tractor using mid-PTO) (Must also order mounting kit p/n 7164820) (Must have mid-PTO installed on tractor) (Price includes \$135 for installation)	\$1,940.00	24.0%	\$135.00	\$1,609.40

Part Number	Rear Ballast Box Description	SLP in US\$	Discount percent	Labor	Price
-------------	------------------------------	-------------	------------------	-------	-------

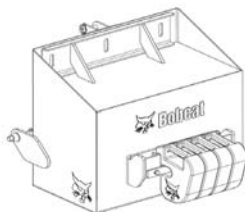

(CT1021, CT1025, CT2025, CT2035, CT2040, CT2535, CT2540, CT4045, CT4050, CT4055, CT4058, CT5545, CT5550, CT5555, CT5558) 7365584	Rear Ballast Box	\$465.00	24.0%	\$135.00	\$488.40
<p>To achieve the maximum loader lift capacity that is published in all Bobcat specifications, follow the guide lines shown below for adding weight to the rear ballast box and adding liquid ballast to the rear tractor tires.</p> <p>(Price includes \$135 for installation)</p>					

Part Number	Rotary Cutter Description	SLP in US\$	Discount percent	Labor	Price
-------------	---------------------------	-------------	------------------	-------	-------

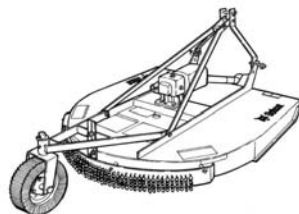

(CT1021, CT1025) 7365689	3 PT. ROTARY CUTTER 48", (3RC48) (Tractor must be equipped with a front-end loader or front ballast kit) (Price includes \$135 for installation)	\$1,352.00	24.0%	\$135.00	\$1,162.52
(CT2025, CT2035, CT2040, CT2535, CT2540, CT4045, CT4050) 7365545	3 PT. ROTARY CUTTER 60", (3RC60) (Tractor must be equipped with a front-end loader or front ballast kit) (Price includes \$135 for installation)	\$1,560.00	24.0%	\$135.00	\$1,320.60
(CT2035, CT2040, CT2535, CT2540, CT4045, CT4050, CT4055, CT4058, CT5545, CT5550, CT5555, CT5558) 7365693	3 PT. ROTARY CUTTER 72", (3RC72) (Tractor must be equipped with a front-end loader or front ballast kit) (Price includes \$135 for installation)	\$1,755.00	24.0%	\$135.00	\$1,468.80

Part Number	Snowblower Description	SLP in US\$	Discount percent	Labor	Price
-------------	------------------------	-------------	------------------	-------	-------

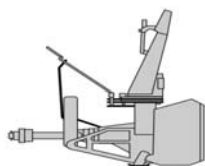

(CT1021, CT1025) 7366570	3 PT. SNOW BLOWER 50", SB50 (Includes manual chute rotator.) (CT1021/CT1025 tractors must be equipped with front-end loader)	\$1,798.00	24.0%	\$0.00	\$1,366.48
(CT2025, CT2035, CT2040, CT2535, CT2540) 7366566	3 PT. SNOW BLOWER 60", SB60 (Includes manual chute rotator.) (Hydraulic Chute rotator is available as a dealer installed accessory) (CT2025-CT2540 tractors must be equipped with front-end loader)	\$2,046.00	24.0%	\$0.00	\$1,554.96
(CT2035, CT2040, CT2535, CT2540, CT4045, CT4050, CT4055, CT4058, CT5545, CT5550, CT5555, CT5558) 7365785	3 PT. SNOW BLOWER 66", SB66 (Includes manual chute rotator.)(Hydraulic Chute rotator is available as dealer installed accessory)	\$2,294.00	24.0%	\$0.00	\$1,743.44
(CT4050, CT4055, CT4058, CT5545, CT5550, CT5555, CT5558) 7365781	3 PT. SNOW BLOWER 74", SB74 (Includes manual chute rotator.)(Hydraulic Chute rotator is available as dealer installed accessory)	\$2,914.00	24.0%	\$0.00	\$2,214.64

Part Number	Tiller - Three Point Description	SLP in US\$	Discount percent	Labor	Price
-------------	----------------------------------	-------------	------------------	-------	-------

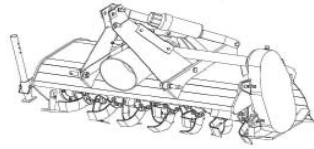

(CT1021*, CT1025*) 7365789	3 PT. TILLER 48", 3TLR48 **Requires Tractors to be equipped with front ballast weights or front end loaders (Price includes \$135 for installation)	\$1,674.00	24.0%	\$135.00	\$1,407.24
(CT2025, CT2035, CT2040, CT2535, CT2540, CT4045, CT4050, CT4055) 7365793	3 PT. TILLER 60", 3TLR60 (Price includes \$135 for installation)	\$1,798.00	24.0%	\$135.00	\$1,501.48
(CT4045, CT4050, CT4055, CT4058, CT5545, CT5550, CT5555, CT5558) 7365797	3 PT. TILLER 72", 3TLR72 (Price includes \$135 for installation) **Requires Tractors to be equipped with front ballast weights or front end loaders	\$2,170.00	24.0%	\$135.00	\$1,784.20

Part Number	Tine Rakes Description	SLP in US\$	Discount percent	Labor	Price
-------------	------------------------	-------------	------------------	-------	-------

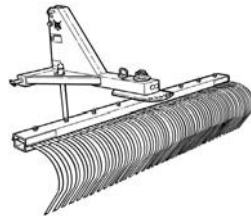

(CT1021, CT1025, CT2025, CT2035, CT2040, CT2535, CT2540) 7365535	3 PT. TINE RAKE 60", 3TR60 (Price includes \$135 for installation)	\$630.00	24.0%	\$135.00	\$613.80
(CT2025, CT2035, CT2040, CT2535, CT2540, CT4045, CT4050, CT4055, CT4058, CT5545, CT5550, CT5555, CT5558) 7365541	3 PT. TINE RAKE 72", 3TR72 (Price includes \$135 for installation)	\$720.00	24.0%	\$135.00	\$682.20
(CT2035, CT2040, CT2535, CT2540, CT4045, CT4050, CT4055, CT4058, CT5545, CT5550, CT5555, CT5558) 7189117	Tine Rake 84", 3TR84 (Price includes \$135 for installation)	\$780.00	24.0%	\$135.00	\$727.80

Part Number	Front End Loader Description	SLP in US\$	Discount percent	Labor	Price
-------------	------------------------------	-------------	------------------	-------	-------

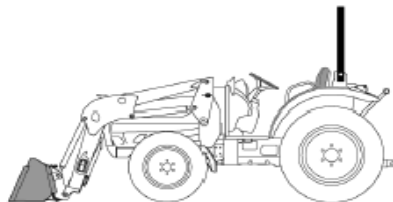

(CT1021, CT1025) 7362893	FL6 (DEALER INSTALLED) (Price includes \$370 for installation)	\$3,530.00	24.0%	\$370.00	\$3,052.80
(CT2025) 7366318	FL7 (DEALER INSTALLED) (Price includes \$370 for installation)	\$4,120.00	24.0%	\$370.00	\$3,501.20
(CT2035, CT2040, CT2535, CT2540) 7366326	FL8 (DEALER INSTALLED) (Price includes \$370 for installation)	\$4,854.00	24.0%	\$370.00	\$4,059.04
(CT4045, CT4050, CT4055, CT4058) 7366333	FL9 (DEALER INSTALLED) (Price includes \$370 for installation)	\$6,329.00	24.0%	\$370.00	\$5,180.04
(CT5545, CT5550, CT5555, CT5558)					

7367078	FL9-5 (DEALER INSTALLED) (Price includes \$370 for installation)	\$6,914.00	24.0%	\$370.00	\$5,624.64
---------	--	------------	-------	----------	------------

Part Number	Quick Hitch Description	SLP in US\$	Discount percent	Labor	Price
-------------	-------------------------	-------------	------------------	-------	-------

(CT1021, CT1025, CT2025, CT2035, CT2040, CT2535, CT2540, CT4045, CT4050, CT4055, CT4058, CT5545, CT5550, CT5555, CT5558)

7376709	QUICK HITCH	\$213.00	24.0%	\$135.00	\$296.88
---------	--------------------	----------	-------	----------	----------



Part Number	Utility Vehicles Description	SLP in US\$	Discount Percent	Destination Charges	Price
-------------	------------------------------	-------------	------------------	---------------------	-------

M1303	3400 Utility Vehicle - Gas	\$13,420.00	20.0%	0.00	\$10,736.00
-------	----------------------------	-------------	-------	------	-------------

M1501	UV34 Utility Vehicle- Diesel	\$16,406.00	20.0%	0.00	\$13,124.80
-------	------------------------------	-------------	-------	------	-------------



Part Number	Utility Vehicles Description	SLP in US\$	Discount Percent	Labor Charges	Price
-------------	------------------------------	-------------	------------------	---------------	-------

M1307	3400XL Utility Vehicle - Gasoline	\$15,440.00	20.0%	0.00	\$12,352.00
-------	-----------------------------------	-------------	-------	------	-------------

M1505	UV34XL Utility Vehicle - Diesel	\$17,886.00	20.0%	0.00	\$14,308.80
-------	---------------------------------	-------------	-------	------	-------------





Part Number	Angle Broom Description	SLP in US\$	Discount Percent	Labor	Price
-------------	-------------------------	-------------	------------------	-------	-------

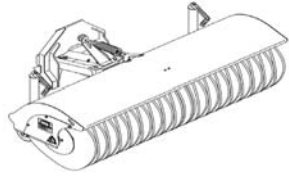

(3650) 7223575	Angle Broom, 70" (Incls PTO-Category 1 Driveline, shear bolt drive protection, replaceable wafer bristles & adj wheels) *Must also Order Auxiliary Relief Kit - PN 7225134	\$5,231.00	24.0%	\$0.00	\$3,975.56
-------------------	---	------------	-------	--------	------------

Part Number	Bucket Description	SLP in US\$	Discount Percent	Labor	Price
-------------	--------------------	-------------	------------------	-------	-------

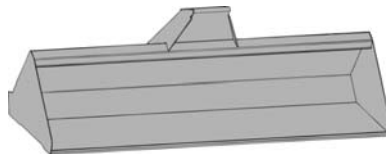

(3450) 7120326	Bucket, 60" (Has a ROC of 5.8 cubic feet SAE heaped capacity)	\$855.00	24.0%	\$0.00	\$649.80
-------------------	---	----------	-------	--------	----------

(3650) 7204758	Bucket, 62" (Has a ROC of 500 lbs and an ISO Heaped Capacity of 4.7 ft ³)	\$627.00	24.0%	\$0.00	\$476.52
-------------------	---	----------	-------	--------	----------

Part Number	Grapple Description	SLP in US\$	Discount Percent	Labor	Price
-------------	---------------------	-------------	------------------	-------	-------

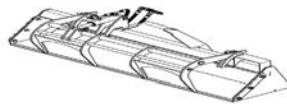

(3650) 7254422	Grapple (Incls Cylinder and Grapple Teeth to be assembled onto the 62" UTV Bucket) (Must Also Order 62" Bucket, PN 7204758) (Must Also Order PN 7025121 - Auxiliary Relief Valves and install) (Price includes \$180 for installation - Install grapple on bucket)	\$763.00	24.0%	\$180.00	\$759.88
-------------------	--	----------	-------	----------	----------

Part Number	Landplane Description	SLP in US\$	Discount Percent	Labor	Price
-------------	-----------------------	-------------	------------------	-------	-------

(3650) 7274196	Landplane (Scarifier and grade kit available)	\$928.00	24.0%	\$0.00	\$705.28
-------------------	---	----------	-------	--------	----------

Part Number	Mower Description	SLP in US\$	Discount Percent	Labor	Price
-------------	-------------------	-------------	------------------	-------	-------





(3650)
7211700

Mower, 66"

(Incls anti-scalp wheels & blade rotation indicators)

For Radiator Protection, is it recommended to also order the Debris Screen Kit - PN 7213588

\$3,741.00

24.0%

\$0.00

\$2,843.16

Part Number	Pallet Forks Description	SLP in US\$	Discount Percent	Labor	Price
-------------	--------------------------	-------------	------------------	-------	-------

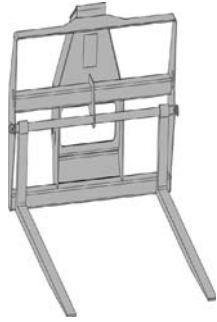

(3650) 7120346	Pallet Forks and Frame	\$1,128.00	24.0%	\$0.00	\$857.28
-------------------	-------------------------------	------------	-------	--------	----------

(3650) 7204847	Pallet Fork Frame and Teeth (Has a ROC of 450 lbs at 18" on the pallet forks)	\$1,074.00	24.0%	\$0.00	\$816.24
-------------------	---	------------	-------	--------	----------

Part Number	Snow Blade Description	SLP in US\$	Discount Percent	Labor	Price
-------------	------------------------	-------------	------------------	-------	-------

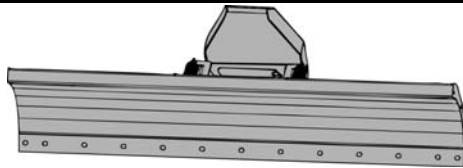

(3650) 7127341	Snow Blade, 68" Hydraulic angle kit required for hydraulic operation of attachment - PN 7129850 Machine must be equipped with auxillary hdraulics if using hydraulic angle kit - PN 102785401CC	\$1,538.00	24.0%	\$0.00	\$1,168.88
-------------------	--	------------	-------	--------	------------

(3650) 7219794	Snow Blade, 69" (Incls Bolt-on replaceable cutting edge) MUST also Order Auxiliary Relief Valve - PN 7025121	\$2,371.00	24.0%	\$0.00	\$1,801.96
7129850	Hydraulic Angle Kit (Needed for 3450 Snow Power with hydraulic Angle)				

Part Number	V-Blade Description	SLP in US\$	Discount Percent	Labor	Price
-------------	---------------------	-------------	------------------	-------	-------

(3650) 7305219	Snow V-Blade (UTV must be equipped with an Attachment Control Kit PN 7304151) (Must also order PN: 7025121 Auxiliary Relief Valves to be installed on 3650)	\$3,303.00	24.0%	\$0.00	\$2,510.28
-------------------	--	------------	-------	--------	------------

Part Number	SnowBlower	SLP in US\$	Discount Percent	Labor	Price
-------------	------------	-------------	------------------	-------	-------

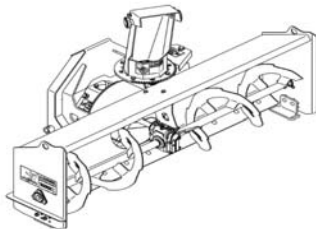

(3650) 7273713	Snowblower, 62" (Incls PTO-Category 1 Driveline, shear bolt protection, adj and replaceable skid shoes and reversible bolt-on cutting edge)	\$5,156.00	24.0%	\$0.00	\$3,918.56
-------------------	---	------------	-------	--------	------------

Part Number	Spreader	SLP in US\$	Discount Percent	Labor	Price
-------------	----------	-------------	------------------	-------	-------

Number	Description	Percent			
(3400 (MY15), 3600 (MY15), 3650 (MY15))					
7257476	UTV Spreader (Incls controller, wire harness, vibrator and all necessary mtg hdwe) (It is recommended that a rear light kit (PN 7257462) and side mirror kit (PN 7204856) be installed on the spreader)	\$3,960.00	24.0%	\$180.00	\$3,189.60



250 East Beaton Drive
West Fargo, ND 58078
T: 701-241-8700

September 12, 2019

Subj: IFB #020-E

Association of Educational Purchasing Agencies (AEPA)
Oakland Schools, 2111 Pontiac Lake Road,
Waterford, MI 48328

Dear Source Selection Official,

Clark Equipment Company dba Bobcat Company is very excited to submit this proposal in response to your RFP for Lawn and Groundskeeping Equipment Supplies and Services. Bobcat Company leads the industry in the design, manufacture, marketing and distribution of compact equipment for construction, rental, landscaping, agriculture, grounds maintenance, government, utility, industry and mining. We strive to empower our customers to do their jobs more efficiently and effectively.

Bobcat Company would like to present the following product lines, deeply discounted and available for streamlined ordering to the Commonwealth along with any States interested in participating:

Product Category	% off MSRP
Bobcat® Mini-Track Loader	20%
Bobcat® Toolcat	20%
Bobcat® Utility Vehicles	20%
Bobcat® Compact Utility Tractors	20%
Attachments or Implements for the Above	24%

Thank you for this opportunity to earn your business. If you have any questions, please don't hesitate to contact me at (701) 241-8759.

Respectfully,

Jesse Rheault
Government Account Manager
Bobcat Company
Mobile: 701-630-5134
Jesse.rheault@doosan.com



Specifications

Toolcat Utility Work Machine



Model	5600	5610
PERFORMANCE		
Rated Lift Capacity (Lift Arm)	1,500 lb. (679 kg)	1,500 lb. (679 kg)*
Cargo Box Capacity	2,000 lb. (905.3 kg)	–
Towing Capacity	4,000 lb. (1810.7 kg)	4,000 lb. (1810.7 kg)
3-Point Hitch Capacity (24 in. Behind Lift Points)	–	1,775 lb. (805 kg)
PTO Horsepower	–	25 hp (18.6 kW)
Storage Bin Capacity (Each)	–	50 lb. (22 kg)
Machine Rated Capacity (combined weight of load on lift arm, cargo box load, operator and passenger)	2,200 lb. (996 kg)	2,200 lb. (996 kg)
Total Rated Capacity (combined weight of load on lift arm, cargo box load, operator and passenger, and tow weight if equipped with a hitch)	4,200 lb. (1901 kg)	4,200 lb. (1901 kg)
Travel Speeds		
Low range	0-8 mph (0-12.9 km/hr.)	0-8 mph (0-12.9 km/hr.)
High range	0-17 mph (0-27.3 km/hr.)	0-17 mph (0-27.3 km/hr.)
Reverse	0-8.5 mph (0-14.2 km/hr.)	0-8.5 mph (0-14.2 km/hr.)
Travel Speeds with optional 29 x 10.5-15 tires		
Low range	0-9 mph (0-14.4 km/hr.)	0-9 mph (0-14.4 km/hr.)
High range	0-18 mph (0-28.9 km/hr.)	0-18 mph (0-28.9 km/hr.)
Reverse	0-9 mph (0-15 km/hr.)	0-9 mph (0-15 km/hr.)
DIMENSIONS		
Cab Height	81 in. (2057 mm)	81 in. (2057 mm)
Cab Height with optional 29 x 10.5-15 tires	82 in. (2083 mm)	82 in. (2083 mm)
Overall Length	181.6 in. (4616 mm)	180.8 in. (4592 mm)
Overall Width	60 in. (1525 mm)	60 in. (1525 mm)
Ground Clearance	8.0 in. (203 mm)	8.0 in. (203 mm)
Ground Clearance with optional 29 x 10.5-15 tires	9.1 in. (231 mm)	9.1 in. (231 mm)
Operating Weight	5,685 lb. (2579 kg)	5,835 lb. (2647 kg)
Outside Turning Diameter (AWS)	17.5 ft. (5337 mm)	17.5 ft. (5337 mm)
Lift Height	83.3 in. (2117 mm)	83.3 in. (2117 mm)
Lift Height with optional 29 x 10.5-15 tires	84.3 in. (2143 mm)	84.3 in. (2143 mm)
ENGINE		
Horsepower	61 hp	61 hp
Engine Type	Diesel	Diesel
Fuel Tank Capacity	20 gal. (76.1 L)	20 gal. (76.1 L)
Machine Shutdown Protection Feature	Std	Std
Battery Rundown Protection	Std	Std
Bobcat SmartFan	Std	Std
Horsepower Management	Std	Std
MACHINE FEATURES		
COMFORT FEATURES		
Cab with Heat and Air Conditioning	Opt	Opt
Cruise Control	Std	Std
Radio/CD Player	Opt	Opt
Driver's Side Suspension Seat	Opt	Opt
Floorboard Riser Kit	Opt	Opt
Intermittent Windshield Wipers	Std	Std
Step Kit	Opt	Opt
Front Work Lights	Std	Std
Rear Work Lights	Opt	Opt
Road Light Kit	Opt	Opt
PERFORMANCE FEATURES		
Four-Wheel Drive	Std	Std
Four-Wheel Independent Suspension	Std	Std
Limited Slip Differentials	Std	Std
Traction Control	Opt	Std
2-Speed Transmission	Std	Std
Hydraulic Dump Cargo Box	Std	–
Rear Window Guard	Opt	–
2 in. Rear Receiver Hitch	Std	Std
PTO	–	Opt
3-pt. Hitch	–	Opt
Rear Remote Hydraulics	Opt	Opt
MACHINE SAFETY FEATURES		
ROPS/FOPS Approved Cab Structure	Std	Std
Toolcat Interlock Control System (TICS™)	Std	Std
Back-up Alarm and Horn	Opt	Opt
Keyless Start System	Opt	Opt
FEATURES FOR ATTACHMENTS		
Auxiliary Hydraulics	Std	Std
Hydraulic Standard Flow	18.9 gpm (71.4 L/min.)	18.9 gpm (71.4 L/min.)
Hydraulic High Flow (Optional)	27.9 gpm (107.4 L/min.)	27.9 gpm (107.4 L/min.)
Hydraulic Pressure	3,000 psi (207 Bar)	3,000 psi (207 Bar)
Power Bob-Tach Mounting System	Opt	Std
Pressure Release Hydraulic Quick Couplers	Std	Std
Fingertip Auxiliary Control	Std	Std
Attachment Control Kit	Opt	Opt
Lift Arm Float Functionality	Std	Std
Dual Direction Detent	Std	Std
Work Mode	Std	Std



The Toolcat 5600 offers over 6 ½ feet of lift height for loading or placing materials.



The Toolcat 5610 3-point hitch can utilize Bobcat implements – plus all of your Category 1, 3-point hitch implements from other manufacturers.



Compact and agile, the Toolcat utility work machines achieve a tighter turning radius than most ATVs. All-wheel steer allows you to maneuver in tight spaces without having to back up and reposition. Turn around trees and through tight corners, and get in and out of small barns and buildings.



Train operators and technicians in the safe operation and servicing of Bobcat equipment. Operator training courses, safety videos and other training materials are available at your Bobcat dealer's parts department or online at Bobcat.com/Training

Specifications

Model	CT1021	CT1025	CT1035	CT1040	CT1045	CT1050	CT1055
Engine	Diesel	Diesel	Diesel	Diesel	Diesel	Diesel	Diesel
Gross horsepower	21 hp (15.7 kW)	24.5 hp (18.2 kW)	34.9 hp (26.2 kW)	39.6 hp (29.3 kW)	44.9 hp (33.3 kW)	50 hp (37.3 kW)	55 hp (41 kW)
No. of cylinders	3	3	3	3	3	3	3
Total displacement	69 cu. in. (1.13 lcc)	100.5 cu. in. (1.647 cc)	111.4 cu. in. (1.826 cc)	111.4 cu. in. (1.826 cc)	111.4 cu. in. (1.826 cc)	111.4 cu. in. (1.826 cc)	111.4 cu. in. (1.826 cc)
Fuel tank capacity (gallons)	6.7 gal. (25.5 L)	9.0 gal. (34.1 L)	9.0 gal. (34.1 L)	9.0 gal. (34.1 L)	9.0 gal. (34.1 L)	11.9 gal. (45.1 L)	11.9 gal. (45.1 L)
3-Point PTO & Hydraulics							
PTO horsepower	18.7 hp (13.9 kW)	22.2 hp (16.6 kW)	33.8 hp (23.3 kW)	34.9 hp (26.2 kW)	41.4 hp (31 kW)	45.6 hp (34 kW)	49.6 hp (37 kW)
3-Point Hitch	Category 1	Category 1	HST (29.4 hp (21.9 kW))	HST (31.2 hp (23.3 kW))	HST (32.8 hp (24.5 kW))	HST (39.3 hp (29.3 kW))	HST (39.3 hp (29.3 kW))
Lift Control Type	Hydraulic Position Control System	Hydraulic Position Control System	Hydraulic Position Control System	Hydraulic Position Control System	Hydraulic Position Control System	Hydraulic Position Control System	Hydraulic Position Control System
Lift Capacity at 24" Behind LH Points (per SAE J283)	700 lb. (318 kg)	1631 lb. (740 kg)	1631 lb. (740 kg)	1631 lb. (740 kg)	1631 lb. (740 kg)	2716 lb. (1232 kg)	2716 lb. (1232 kg)
Rear PTO	540 rpm	540 rpm	540 rpm	540 rpm	540 rpm	540 rpm	540 rpm
Rear PTO System	Independent	Like	Like	Like	Independent	Independent	Independent
Mid-PTO	Standard/2200 rpm	Optional/2000 rpm	Optional/2000 rpm	Optional/2000 rpm	Optional/2000 rpm	Optional/2000 rpm	Optional/2000 rpm
Total Hydraulic Pump Capacity	6.5 gpm (24.6 L/min.)	11.7 gpm (44.4 L/min.)	11.7 gpm (44.4 L/min.)	11.7 gpm (44.4 L/min.)	14.5 gpm (55.1 L/min.)	14.5 gpm (55.1 L/min.)	14.5 gpm (55.1 L/min.)
Rear Hydraulics (optional)	2 Pairs	2 Pairs	2 Pairs	2 Pairs	2 Pairs	2 Pairs	2 Pairs
Telescopic Shovelers	Turbuckle	Turbuckle	Standard	Standard	Standard	Standard	Standard
Lower Links	Rigid	Rigid	Rigid	Rigid	Rigid	Rigid	Rigid
Lifting Rod	Turbuckle	Turbuckle	Crack	Crack	Crack	Crack	Crack
Drive System							
Standard Transmission	Hydrostatic	Manual (9x3)	Manual (9x3)	Manual (9x3)	Synchro (8x8)	Synchro (8x8)	Synchro (8x8)
Optional Transmission	N/A	HST	HST	HST	HST	HST	HST
Spread Ranges	2 Range	3 Range	3 Range	3 Range	3 Range	3 Range	3 Range
Brakes	Wet Multi-disc	Wet Multi-disc	Wet Multi-disc	Wet Multi-disc	Wet Multi-disc	Wet Multi-disc	Wet Multi-disc
Rear Differential Lock	Std	Std	Std	Std	Std	Std	Std
Four-Wheel Drive	Std	Std	Std	Std	Std	Std	Std
2WD	N/A	N/A	N/A	N/A	N/A	N/A	N/A
Travel Speeds (w/ Ag Tires)							
Forward	0-10.31 mph (0-16.6 km/hr.)	0-10.31 mph (0-16.6 km/hr.)	0-14.65 mph (0-23.56 km/hr.)	0-15.16 mph (0-24.4 km/hr.)	0-15.16 mph (0-24.4 km/hr.)	0-15.16 mph (0-24.4 km/hr.)	0-15.16 mph (0-24.4 km/hr.)
Reverse	0-6.96 mph (0-11.2 km/hr.)	0-6.96 mph (0-11.2 km/hr.)	11.8-9.56 mph (1.9-15.39 km/hr.)	11.8-9.56 mph (1.9-15.39 km/hr.)	11.8-9.56 mph (1.9-15.39 km/hr.)	11.8-9.56 mph (1.9-15.39 km/hr.)	11.8-9.56 mph (1.9-15.39 km/hr.)
Dimensions							
Overall Length (w/ 3 pt.)	92.1 in. (2493 mm)	92.1 in. (2493 mm)	120.9 in. (3070 mm)	120.9 in. (3070 mm)	120.9 in. (3070 mm)	124.3 in. (3157 mm)	124.3 in. (3157 mm)
Overall Width (w/ ag tires)	46.5 in. (1182 mm)	46.5 in. (1182 mm)	55.1 in. (1400 mm)	55.1 in. (1400 mm)	55.1 in. (1400 mm)	62.8 in. (1596 mm)	62.8 in. (1596 mm)
Overall Height (w/ ROPS up)	88 in. (2236 mm)	88 in. (2236 mm)	99.2 in. (2520 mm)	99.2 in. (2520 mm)	99.2 in. (2520 mm)	92 in. (2338 mm)	92 in. (2338 mm)
Wheelbase	55.1 in. (1400 mm)	55.1 in. (1400 mm)	66.7 in. (1670 mm)	66.7 in. (1670 mm)	66.7 in. (1670 mm)	71.3 in. (1810 mm)	71.3 in. (1810 mm)
Ground Clearance	6.4 in. (162 mm)	6.4 in. (162 mm)	13.4 in. (340 mm)	13.4 in. (340 mm)	13.4 in. (340 mm)	14.5 in. (368 mm)	14.5 in. (368 mm)
Weight	1485 lb. (675 kg)	1485 lb. (675 kg)	2670 lb. (1215 kg)	3397 lb. (1541 kg)	3397 lb. (1541 kg)	3373 lb. (1530 kg)	3373 lb. (1530 kg)
Steering							
Inside Steering Radius	8.2 ft. (2.54 m)	8.2 ft. (2.54 m)	8 ft. (2.4 m)	8 ft. (2.4 m)	8 ft. (2.4 m)	10.32 in. (260.0 mm)	10.32 in. (260.0 mm)
Tilt Steering Wheel	N/A	N/A	N/A	N/A	N/A	Standard	Standard
Safety Equipment							
Safety Interlock System (neutral start-operating)	Std	Std	Std	Std	Std	Std	Std
Fold Down ROPS (roll-over protective structure)	Std	Std	Std	Std	Std	Std	Std
Fully Retractable Seatbelt	Std	Std	Std	Std	Std	Std	Std
Features							
Suspension Seat	Std	Std	Std	Std	Std	Std	Std
Adjustable Seat	Std	Std	Std	Std	Std	Std	Std
Cup Holder	Std	Std	Std	Std	Std	Std	Std
Glow Plug Engine Pre-heat	Std	Std	Std	Std	Std	Std	Std
Touchscreen	Std	Std	Opt	Opt	Opt	Std	Std
Rear Lights (Tail Lights/Brake Lights)	Std	Std	Opt	Opt	Opt	Std	Std
Cruise Control	Opt	Opt	Opt	Opt	Opt	Opt	Opt
Spark Arrestor/Muffler	Std	Std	Std	Std	Std	Std	Std
Horn/Hazard Flasher/Turn Signals	Std	Std	Std	Std	Std	Std	Std
Rear Working Lights	Opt	Opt	Opt	Opt	Opt	Opt	Opt
Side Mirror	Opt	Opt	Opt	Opt	Opt	Opt	Opt

*Note: Hydraulic 3-pt. lift capacity will vary depending on lift point height.



Certain specifications are based on engineering calculations and are not actual measurements. Specifications are provided for comparison purposes only and are subject to change without notice. Specifications for your individual Bobcat equipment will vary based on normal variations in design, manufacturing, operating conditions, and other factors.



Specifications

Model	CT1058	CT1545	CT1550	CT1555	CT1558
Engine	Diesel	Diesel	Diesel	Diesel	Diesel
Gross horsepower	57 hp (43 kW)	45 hp (33.5 kW)	50 hp (37.3 kW)	55 hp (41 kW)	57.7 hp (43 kW)
No. of cylinders	3	3	3	3	3
Total displacement	111.4 cu. in. (1826 cc)	111.4 cu. in. (1826 cc)	111.4 cu. in. (1826 cc)	111.4 cu. in. (1826 cc)	111.4 cu. in. (1826 cc)
Rear Tank Capacity (gallons)	12.7 gal. (48 L)	14.8 gal. (56 L)	14.8 gal. (56 L)	14.8 gal. (56 L)	14.8 gal. (56 L)

3-Point, PTO & Hydraulics

PTO Horsepower	45.1 hp (33.7 kW)	33.9 hp (25.3 kW)	38.9 hp (29 kW)	43.1 hp (32.1 kW)	48.3 hp (36 kW)
3-Point Hitch	Category I				
Hydraulic Position Control System	Category I				
Lift Capacity at 24" Behind Lift Points (per SAE J283)	276 lb. (122 kg)	284 lb. (129 kg)	284 lb. (129 kg)	290 lb. (131 kg)	298 lb. (135 kg)
Rear PTO System	540 rpm	540 rpm	540 rpm	540 rpm	540 rpm
Mid-PTO	Optional: 2000 rpm	Optional: 2000 rpm	Optional: 2000 rpm	Optional: 2000 rpm	Optional: 2000 rpm
Total Hydraulic Pump Capacity	16.5 gpm (62.4 L/min.)	17.9 gpm (67.6 L/min.)	17.9 gpm (67.6 L/min.)	17.9 gpm (67.6 L/min.)	17.9 gpm (67.6 L/min.)
Rear Hydraulics (optional)	2 Ports Standard	Single/Dual Remote Hydraulic Valve	Single/Dual Remote Hydraulic Valve	Single/Dual Remote Hydraulic Valve	Single/Dual Remote Hydraulic Valve
Telescopic Stabilizers	Standard	Standard	Standard	Standard	Standard
Lower Links	Rigid	Telescopic	Telescopic	Telescopic	Telescopic
Upper Link	Crank	Draft Control	Draft Control	Draft Control	Draft Control

Drive System

Standard Transmission	HST	Hydrostatic	Hydrostatic	Hydrostatic	Hydrostatic
Speed Ranges	3 Range	3 Range	3 Range	3 Range	3 Range
Brakes	Wet Multi-disc	Wet Multi-disc	Wet Multi-disc	Wet Multi-disc	Wet Multi-disc
Rear Differential Lock	Std	Std	Std	Std	Std
Four-Wheel Drive	Std	Std	Std	Std	Std
2WD	N/A	N/A	N/A	N/A	N/A

Travel Speeds (w/ Ag. Tires)

Forward	0-18.5 mph (29.7 km/hr.)	0-17.79 mph (28.63 km/hr.)	0-17.79 mph (28.63 km/hr.)	0-17.79 mph (28.63 km/hr.)	0-17.79 mph (28.63 km/hr.)
Reverse	0-12.9 mph (20.8 km/hr.)	0-12.9 mph (20.8 km/hr.)	0-12.9 mph (20.8 km/hr.)	0-12.9 mph (20.8 km/hr.)	0-12.9 mph (20.8 km/hr.)

Dimensions

Overall Length (w/ 3-pt.)	125.5 in. (3189 mm)	139.6 in. (3547 mm)	139.6 in. (3547 mm)	139.6 in. (3547 mm)	139.6 in. (3547 mm)
Overall Width (w/ ag. tires)	62.8 in. (1598 mm)	65.6 in. (1666 mm)	65.6 in. (1666 mm)	65.6 in. (1666 mm)	65.7 in. (1668 mm)
Overall Height (w/ ROPS up)	96.8 in. (2458 mm)	95.6 in. (2429 mm)	95.6 in. (2429 mm)	95.5 in. (2429 mm)	96.5 in. (2452 mm)
Wheelbase	71.5 in. (1810 mm)	75.6 in. (1920 mm)	75.6 in. (1920 mm)	75.6 in. (1920 mm)	75.6 in. (1920 mm)
Ground Clearance	14.5 in. (368 mm)	13.1 in. (335 mm)	13.1 in. (335 mm)	13.7 in. (350 mm)	13.7 in. (350 mm)
Weight	3522 lb. (1598 kg)	4315 lb. (1957 kg)	4315 lb. (1957 kg)	4520 lb. (2050 kg)	4520 lb. (2050 kg)

Steering

Inside Turning Radius	103.2 in. (2630 mm)	118.7 in. (2990 mm)	118.7 in. (2990 mm)	120.7 in. (3040 mm)	120.7 in. (3040 mm)
T14 Steering Wheel	Standard	Standard	Standard	Standard	Standard

Safety Equipment

Safety Interlock System (neutral start-operating)	Std	Std	Std	Std	Std
Fold Down ROPS (rollover protective structure)	Std	N/A	N/A	N/A	N/A
Fully Retractable Subball	Std	Std	Std	Std	Std

Features

Supplemental Seat	Std	Std	Std	Std	Std
Adjustable Seat	Std	Std	Std	Std	Std
Cup Holder	Std	Std	Std	Std	Std
Glow Plug Engine Pre-heat	Std	Std	Std	Std	Std
Toolbox	Std	Std	Std	Std	Std
Head Lights/Rail Light/Brake Lights	Std	Std	Std	Std	Std
Cruise Control	Std	Std	Std	Std	Std
Spark Arrestor Muffler	Std	Std	Std	Std	Std
Horn/Hazard Flasher/Turn Signals	Std	Std	Std	Std	Std
Rear Working Lights	Opt	Std	Std	Std	Std
Side Mirror	Std	Std	Std	Std	Std

*Note: Hydraulic 3-pt. lift capacity will vary depending on lift point height.

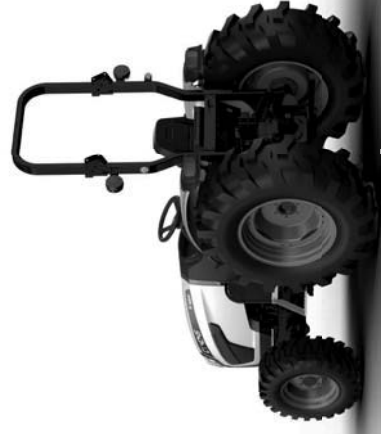

4 WHEEL DRIVE

3 CYLINDER ENGINES

540 RPM REAR PTO



Bobcat

ATTACHMENTS AND IMPLEMENTS

Without attachments or implements, it just wouldn't be Bobcat equipment. Bobcat attachments and implements are a significant source of versatility and value for customers. With the Bobcat brand reputation as the choice of professionals and homeowners alike, owners can be sure they'll find the right tool for any job.

PRIMARY ATTACHMENTS

BOBCAT	PRIMARY ATTACHMENT MODEL NAME		
	FEL	BHL	MM
CT1021	FL6	BH66	M60
CT1023	FL6	BH66	M60
CT2025	FL7	BH76	M60
CT2035	FL8	BH76	
CT2040	FL8	BH76	
CT2535	FL8	BH76	
CT2540	FL8	BH76	
CT4045	FL9	BH86	
CT4050	FL9	BH86	
CT4055	FL9	BH86	
CT4068	FL9	BH86	
CT5545	FL9-5	BH86	
CT5550	FL9-5	BH86	
CT5555	FL9-5	BH86	
CT5556	FL9-5	BH86	

FRONT END LOADER (FEL) SPECIFICATIONS					
MODEL	FL6	FL7	FL8	FL9	FL9-5
MAX. LIFT HEIGHT TO PIVOT PIN	74"	94"	99"	104"	108"
MAX. LIFT HEIGHT UNDER LEVEL BUCKET	65"	88"	93"	94"	103"
CLEARANCE WITH BUCKET DUMPED	51"	72"	74"	75"	83"
REACH AT MAXIMUM LIFT HEIGHT	27"	11.5"	20"	25"	16.5"
MAXIMUM DUMP ANGLE	45	48	50	50	67
REACH WITH BUCKET ON GROUND	52"	62"	62"	67.5"	72"
MAXIMUM ROLLBACK ANGLE	27	32	17	36	29
DIGGING DEPTH	5.25"	5.75"	5.5"	11.5"	8.25"
LIFT CAPACITY AT PIVOT PIN (MAX. HEIGHT) (NOT TESTED)	675 lb.	1376 lb.	1378 lb.	2474 lb.	2760 lb.
BREAKOUT FORCE AT 500 MM	1332 lb. (@Pivot Pin)	1656 lb.	2467 lb.	2758 lb.	2963 lb.
WEIGHT	606 lb.	915 lb.	1070 lb.	1202 lb.	1400 lb.
BUCKET WIDTHS	48"	60"	60"	66"	72"

MID MOUNT MOWER (MM) SPECIFICATIONS	
MODEL	M60
CUTTING WIDTH	60 in. (1524 mm)
CUTTING HEIGHT	1" - 4"
TRANSPORT HEIGHT	6"
GEAR TYPE	Spiral Bevel
NUMBER OF BLADES	3
BLADE SPINDLE SPEED	2888 rpm
BLADE TIP VELOCITY	78.2 m/s
BLADE LENGTH	20.4"
DECK THICKNESS	0.13"
TOTAL WIDTH	73.4"
TOTAL LENGTH	37.9"
TOTAL HEIGHT	10.8"
DRIVE TYPE	U-Joint and V-Belt
LIFTING TYPE	3 Point Hitch Links
COMPATIBLE WITH LOADER	Yes
DRIVE OVER DECK	Yes

BACKHOE LOADER (BHL) SPECIFICATIONS				
MODEL	BH66	BH76	BH86	BH86
REACH FROM CENTER LINE OF SWING PIVOT	DIGGING DEPTH (2' FLAT BOTTOM) 84"	90"	94.5"	94.5"
LOADING HEIGHT (BUCKET AT 60°)	114"	125"	136"	136"
MAXIMUM LEVELING ANGLE	52°	72°	80°	80°
SWING ARC	8 deg.	10 deg.	10 deg.	10 deg.
TRANSPORT HEIGHT (MAXIMUM)	150 deg.	180 deg.	180 deg.	180 deg.
BUCKET ROTATION	163 deg.	180 deg.	180 deg.	180 deg.
STABILIZER SPREAD (DOWN POSITION)	88"	69"	69"	69"
STABILIZER SPREAD (UP POSITION)	56"	46.5"	46.5"	46.5"
BUCKET DIGGING FORCE	2096 lbf.	2818 lbf.	3748 lbf.	3748 lbf.
DIPPERSTOCK DIGGING FORCE	1160 lbf.	2105 lbf.	2205 lbf.	2205 lbf.
OPERATING PRESSURE	1885 psi	2466 psi	2466 psi	2466 psi
WEIGHT (WITHOUT BUCKET)	657 lb.	880 lb.	1102 lb.	1102 lb.



ATTACHMENTS AND IMPLEMENTS

3-POINT ATTACHMENTS

BOBCAT	TRACTOR HITCH (INCHES)	3-POINT ATTACHMENTS							AUGER
		BOX BLADE	ANGLE BLADE	RAKE	ROTARY CUTTER	TILLER	SNOW BLOWER	FINISH MOWER	
CT1021	46.7	48	60	60	48	48	50	555 (60)	160
CT1025	46.7	48	60	60	48	48	50	555 (60)	160
CT2025	55.1	60	60	60	60	60	60	555 (60), 655 (72)	160
CT2035	55.1	60	60	60	60	60	60, 66	555 (60), 655 (72)	160, 205
CT2040	55.1	60	60	60	60	60	60, 66	555 (60), 655 (72)	160, 205
CT2535	54.5	60	60	60	60	60	60, 66	555 (60), 655 (72)	160, 205
CT2540	54.5	60	60	60	60	60	60, 66	555 (60), 655 (72)	160, 205
CT4045	62.8	72	72	72	60, 72	60, 72	66	655 (72)	205
CT4050	62.8	72	72	72	60, 72	60, 72	66, 74	655 (72)	205
CT4055	62.8	72	72	72	60, 72	60, 72	74	655 (72)	205
CT4058	62.8	72	72	72	60, 72	60, 72	66	655 (72)	205
CT5545	65.6	72	72, 84	72, 84	72	72	66, 74	655 (72)	205
CT5550	65.6	72	72, 84	72, 84	72	72	74	655 (72)	205
CT5555	65.7	72	72, 84	72, 84	72	72	74	655 (72)	205
CT5558	65.7	72	72, 84	72, 84	72	72	74	655(72)	205

3-POINT ATTACHMENTS	SIZE (INCHES)
BOX BLADE	48, 60, 72
ANGLE BLADE	60, 72, 84
RAKE	60, 72, 85
ROTARY CUTTER	48, 60, 72
TILLER	48, 60, 72
SNOW BLOWER	50, 60, 66, 74
FINISH MOWER	60, 72
POST HOLE DIGGER (AUGER)	160, 205 (6" - 30" Bits)
REAR BALLAST BOX	
QUICK HITCH	Category I



SNOWBLOWER SPECIFICATIONS					
MODEL	500	600	660	740	
CUTTING WIDTH	50"	60"	66"	74"	
CUTTING HEIGHT	24"	24"	24"	25"	
FAN	4-Blade	4-Blade	4-Blade	4-Blade	
FAN DIMENSIONS	22" X 7"	22" X 7"	22" X 7"	23" X 7"	
DRIVE FAN	540 rpm (Open Gear)	540 rpm (Open Gear)	540 rpm (Open Gear)	540 rpm (Open Gear)	
AUGER DIAMETER	15"	15"	15"	15"	
SKID SHOES	Adjustable & Replaceable	Adjustable & Replaceable	Adjustable & Replaceable	Adjustable & Replaceable	
HITCH CATEGORY	Category I	Category I	Category I	Category I	
TRACTOR REQUIREMENT	15-30 hp	20-40 hp	22-40 hp	40-70 hp	
WEIGHT	422 lb.	470 lb.	515 lb.	756 lb.	

ROTARY CUTTER SPECIFICATIONS					
MODEL	48	60	60	72	
OVERALL WIDTH	51"	63"	63"	75"	
CUTTING WIDTH	48"	60"	60"	72"	
CUTTING HEIGHT	1.5" to 9"	1.5" to 9"	1.5" to 9"	1.5" to 9"	
OVERALL LENGTH	68"	80"	80"	92"	
DECK TYPE	Single	Single	Single	Single	
DECK THICKNESS	14 ga.	14 ga.	14 ga.	14 ga.	
DRIVELINE	Shear Bolt	Shear Bolt	Shear Bolt	Shear Bolt	
TRACTOR REQUIREMENTS (PTO)	18-45 hp (540 rpm)	20-50 hp (540 rpm)	20-50 hp (540 rpm)	25-65 hp (540 rpm)	
HITCH CATEGORY	Category I	Category I	Category I	Category I	
BLADES (HEAT TREATED SUCTION)	3" x 0.5"	3" x 0.5"	3" x 0.5"	3" x 0.5"	
GEAR BOX (HP RATING)	45	45	45	45	
WEIGHT	360 lb.	460 lb.	460 lb.	580 lb.	

BOX BLADE SPECIFICATIONS					
MODEL	48	60	60	72	
OVERALL WIDTH	48.5"	62"	62"	74"	
CUTTING EDGES (2)	48" (Reversible)	60" (Reversible)	60" (Reversible)	72" (Reversible)	
HEIGHT	32"	33"	33"	33"	
OVERALL LENGTH	28"	31"	31"	31"	
TRACTOR REQUIREMENTS	18-25 hp	20-50 hp	20-50 hp	35-60 hp	
HITCH CATEGORY	Category I	Category I	Category I	Category I	
DIGGING SHANKS	4 (Adjustable/Replaceable)	5 (Adjustable/Replaceable)	5 (Adjustable/Replaceable)	6 (Adjustable/Replaceable)	
WEIGHT	270 lb.	305 lb.	305 lb.	445 lb.	

ATTACHMENTS AND IMPLEMENTS

ANGLE BLADE		
SPECIFICATIONS		
MODEL	60	72
OVERALL WIDTH	60"	72"
CUTTING EDGE	Reversible	Reversible
OVERALL HEIGHT	38"	38"
OVERALL LENGTH	40"	40"
BLADE HEIGHT	15"	15"
HITCH CATEGORY	Category I	Category I
BLADE ANGLING	Manual (5 Pin Positions)	Manual (5 Pin Positions)
WEIGHT	197 lb.	213 lb.

LANDSCAPE RAKE		
SPECIFICATIONS		
MODEL	60	72
OVERALL WIDTH	60"	72"
TINES (CURVED)	High Carbon (Replaceable)	High Carbon (Replaceable)
OVERALL HEIGHT	39"	39"
OVERALL LENGTH	42"	42"
HITCH CATEGORY	Category I	Category I
ANGLING	Manual (360 deg.)	Manual (360 deg.)
WEIGHT	195 lb.	215 lb.

FINISH MOWER		
SPECIFICATIONS		
MODEL	60 (555)	72 (555)
CUTTING WIDTH	60"	72"
CUTTING HEIGHT	1.5" to 5.5"	1.5" to 5.5"
BLADES	3	3
BLADE DIMENSIONS	1/4" x 2-1/4" x 21-3/4"	1/4" x 2-1/4" x 25-3/4"
DECK THICKNESS	7 ga.	7 ga.
TIRES	13 / 500 x 6.4-ply	13 / 500 x 6.4-ply
TRACTOR REQUIREMENTS (PTO)	15-55 hp	20-55 hp
HITCH CATEGORY	Category I	Category I
GEAR BOX	Closed (540 rpm)	Closed (540 rpm)
WEIGHT	627 lb.	627 lb.

TILLER		
SPECIFICATIONS		
MODEL	48	60
OVERALL WIDTH	55"	64"
TILLING WIDTH	48"	60"
HEIGHT	38"	38"
OVERALL LENGTH	28"	28"
DRIVELINE	Gear Driven-Oil Bath	Gear Driven-Oil Bath
TRACTOR REQUIREMENTS (PTO)	18-25 hp (540 RPM)	20-50 hp (540 RPM)
HITCH CATEGORY	Category I	Category I
TINES	Heat Treated/Self Sharp.	Heat Treated/Self Sharp.
ROTATION	Forward or Reverse	Forward or Reverse
DEPTH RUNNERS	1" to 4"	1" to 4"
WEIGHT	591 lb.	638 lb.

POST HOLE DIGGER		
SPECIFICATIONS		
MODEL	160	205
OUTPUT SHAFT	2"	2"
MAIN FRAME MATERIAL	3" Steel Tubing	3.5" Steel Tubing
DRIVELINE	Shear-bolt Protected	Shear-bolt Protected
AUGER BITS	6" - 30" single & double flighted bits	
TRACTOR REQUIREMENTS (PTO)	20-40 hp	35-60 hp
HITCH CATEGORY	Category I	Category I
WEIGHT	160 lb.	205 lb.

QUICK HITCH		
SPECIFICATIONS		
MODEL	CATEGORY I	
INSIDE HOOKS (DISTANCE)	27-1/4"	
OUTSIDE HOOKS (DISTANCE)	29-1/2"	
WEIGHT	76 lb.	

Bobcat Mini Track Loaders

Performance

	MT55	MT85
Rated Operating Capacity	550 lb. (249 kg)	850 lb. (385 kg)
Tipping Load	1,610 lb. (732 kg)	2,458 lb. (1115 kg)
Hydraulic Pump Capacity	12 gpm (45.4 L/min.)	12 gpm (45.4 L/min.)
Travel Speed (forward)	3.5 mph (5.6 km/hr.)	4.0 mph (6.4 km/hr.)
Travel Speed (reverse)	1.5 mph (2.3 km/hr.)	2.9 mph (4.7 km/hr.)
Operating Weight (with bucket)	2,610 lb. (1186 kg)	3,110 lb. (1410 kg)
Ground Pressure	4.9 psi	4.9 psi
Ground Pressure (with wide tracks)	3.5 psi	3.5 psi

Dimensions

	MT55	MT85
Length (without bucket)	72.4 in. (1839 mm)	84.5 in. (2146 mm)
Width (with bucket)	36.0 in. (914 mm)	36.0 in. (914 mm)
Height	49.1 in. (1246 mm)	54.8 in. (1392 mm)
Height to Bucket Pin	71.2 in. (1807 mm)	80.9 in. (2056 mm)

Engine

	D902 E3B/Tier 4	D902 E3B/Tier 4
Model/Emissions Tier (EPA)	D902 E3B/Tier 4	D902 E3B/Tier 4
Fuel/Cooling	Diesel/Liquid	Diesel/Liquid
Cylinders	3	3
HP/Displacement	25 hp (18.6 kW)/ 54.9 cu. in. (0.9 L)	25 hp (18.6 kW)/ 54.9 cu. in. (0.9 L)
Fuel Tank Capacity	7.0 gal. (26.5 L)	7.0 gal. (26.5 L)

Operation

	One-hand drive/steering control	ISO joystick
Steering and Drive	One-hand drive/steering control	ISO joystick
Lift and Tilt	One-lever raise/lower/dump/ rollback control	ISO joystick
Transmission	Hydrostatic track drive system	Hydrostatic track drive system
Attachment	Single lever with dual direction detent	Single lever with dual direction detent

Machine Features and Options

Auxiliary Hydraulics	Std	Std
Choice of Attachment Mounting System	Bob-Tach mounting system or common industry interface (CI) system	Bob-Tach mounting system or common industry interface (CI) system
Continuous Flow Shutoff Lever	Std	Std
Gauges/Warning Lights	Std	Std
Hydrostatic Drive Train	Std	Std
Lift Arm Lockout with Manual Bypass	Std	Std
Lift Arm Support	Std	Std
Lift Hook Locations	Std	Std
Liquid-Cooled Diesel Engine	Std	Std
Neutral Start Interlocks	Std	Std
Parking Brake	Std	Std
Reverse Stop Panel	Std	-
Spark Arrestor Muffler	Std	Std
Tie-Down Locations	Std	Std
Tilt Lockout	Std	Std
Tilt Steering	Std	Std
Track (7 in. wide)	Std	Std
Attachment Mounting System Conversion Kit (convert from CI to Bob-Tach system)	Opt	Opt
Attachment Control Kit	Opt	Opt
Catalytic Exhaust Purifier	Opt	Opt
Engine Block Heater	Opt	Opt
Light Kit	Opt	Opt
Multi-Bar Lug Track	Opt	-
Non-Marking Tracks	Opt	Opt
Ride-On Platform	Opt	Std
Shutdown Kit	Opt	Opt
Case Drain Kit	Opt	Opt
Track (10 in. wide)	Opt	Opt

Perfect for Rental Fleets

With their job-proven technology, easy maintenance, simple controls and impressive performance, Bobcat mini track loaders are perfect for rental applications. Mini track loaders have a smaller, less-intimidating profile than some of our other machines. Plus, they have easy-to-use controls and impressive rated operating capacities of 850 or 550 pounds.

Incredible Versatility

Bobcat mini track loaders aren't just for lifting heavy loads. They're made to run hydraulic attachments as productively as some of our skid-steer loader models.

Attachment Flexibility

Both the MT55 and MT85 are available with our industry-leading Bob-Tach attachment mounting system. You can also choose the Common Industry Interface to utilize your existing mini track loader attachments.

Parts and Service Backup

With every Bobcat product, you get the support of a worldwide network of dealers offering industry-leading attachments, accessories and parts availability. Their factory-trained technicians are equipped to handle all your parts and service requirements, including engine and hydrostatic/hydraulic components.

Unbeatable Bobcat Warranty

The best equipment carries the best warranty! The MT55 and MT85 mini track loaders come with a full one-year warranty with unlimited hours.

Operator Training

An operator safety video is available.

*Certain specification(s) are based on engineering calculations and are not actual measurements. Specification(s) are provided for comparison purposes only and are subject to change without notice. Specification(s) for your individual Bobcat equipment will vary based on normal variations in design, manufacturing, operating conditions, and other factors.

NOTE - Where applicable, dimensions are in accordance with ISO standards. Specifications and design are subject to change without notice. Pictures of Bobcat units may show other than standard equipment. All dimensions are given for loader equipment with standard tracks. All dimensions are shown in inches. Respective metric dimensions are enclosed by parentheses. Bobcat Company complies with the requirements of ISO 9001 as registered with BSI.

Bobcat®, the Bobcat logo and the colors of the Bobcat machine are registered trademarks of Bobcat Company in the United States and various other countries.
©2018 Bobcat Company. All rights reserved.

MT55 Dimensions:

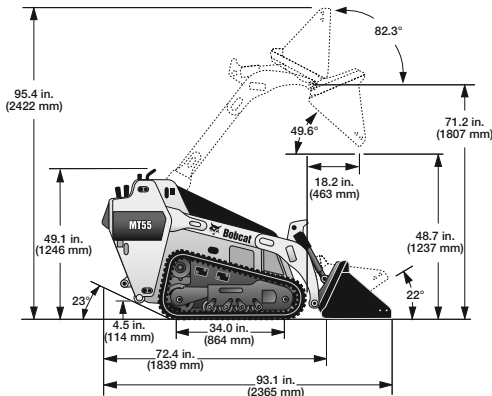

MT85 Dimensions:

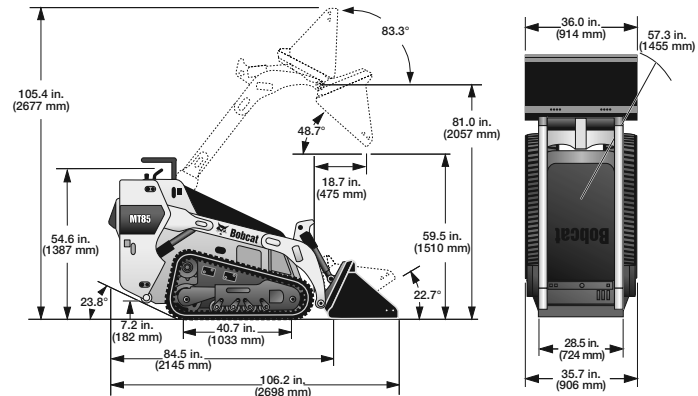

Printed on 10% recycled paper

B-1776 (03/18)



Bobcat

Bobcat Company • P.O. Box 6000 • West Fargo, ND 58078

Printed in U.S.A.

Kn-10.5M-0318-59336-10-F

Get versatile! Hook up to a wide choice of hard-working Bobcat attachments, including:



Angle broom

Sweeps snow, dirt and debris from sidewalks, driveways and warehouse floors.



Auger

Augers holes with speed and plumb-line accuracy. Bits up to 36-in. available.



Backhoe – MT55 only

Excavates in hard-to-reach areas. Ideal for landscaping, nurseries, water and power lines.



Boring unit

Installs utilities under driveways, sidewalks and other obstructions with minimal ground disturbance.



Bucket

Numerous styles and sizes. Designed to handle a wide variety of jobs and materials.



Digger

Removes rocks and stumps, digs trenches, transplants trees. Can be used for anything where a spade is used.



Hydraulic breaker

Breaks up asphalt, concrete and rocks and smashes through walls. Exceptional power.



Grapple (industrial, root, utility)

Three different grapple styles: Industrial bucket grapple for demolition and removal, root grapple for sorting debris while leaving dirt behind, utility fork and grapple or bucket and grapple for light clean-up duties.



Landplane

Grades, levels, transports material, breaks up hard ground and peels sod.



Pallet fork

Handles palletized material and long objects, such as lumber and fence posts.



Snowblower

Throws snow to clear a clean path. Rotating chute and adjustable deflector directs snow where the operator wants it placed.



Soil conditioner

Smooths ruts, moves material, levels mounds and prepares soil for seed or sod.



Stump grinder

Gets into tight areas and quickly grinds tree stumps into mulch.



Tiller

Digs and loosens soil, mixes compost and other materials into existing soil.



Tree fork

With one stationary and one moveable arm, grabs, lifts and transports trees, rocks and other oddly-shaped materials.



Trencher

Handles a wide range of jobs, including trenching close to buildings. Depths down to three feet.



Utility blade

Operates as a snow blade or dozer blade. Moldboard angles up to 30 degrees.



Vibratory plow

Installs flexible pipe and utility cable 6-8 inches in the ground with minimal ground disturbance.

UTV SPECIFICATIONS

Specifications



Vehicle	3400 Gas	3400XL Gas	UV34	UV34 X Diesel
Engine Model	570cc Single	570cc Single	Diesel	Diesel
Engine Cooling	Liquid	Liquid	Liquid	Liquid
Emissions Tier (EPA)	—	—	Tier 4	Tier 4
Engine Fuel	Gasoline EFI	Gasoline EFI	Diesel	Diesel
Horsepower	40 hp (29.8 kW)	40 hp (29.8 kW)	24 hp (17.9 kW)	24 hp (17.9 kW)
Displacement	570 cubic cm	570 cubic cm	900 cubic cm	900 cubic cm
Performance				
Operating Weight	1,640 lb. (744 kg)	1,900 lb. (862 kg)	1,935 lb.	2,165 lb.
Travel Speed (Max) - High	40 mph (64.4 km/hr.)	40 mph (64.4 km/hr.)	40 mph (64.4 km/hr.)	40 mph (64.4 km/hr.)
Travel Speed - Low	16 mph (25.7 km/hr.)	16 mph (25.7 km/hr.)	16 mph (25.7 km/hr.)	16 mph (25.7 km/hr.)
Travel Speed - Reverse	16 mph (25.7 km/hr.)	16 mph (25.7 km/hr.)	16 mph (25.7 km/hr.)	16 mph (25.7 km/hr.)
Capacities				
Fuel Tank	10 gal. (37.8 L)	10 gal. (37.8 L)	12 gal. (37.8 L)	12 gal. (37.8 L)
Cargo Box Length	43.5 in. (1105 mm)	43.5 in. (1105 mm)	43.5 in. (1105 mm)	43.5 in. (1105 mm)
Cargo Box Width	54 in. (1372 mm)	54 in. (1372 mm)	54 in. (1372 mm)	54 in. (1372 mm)
Cargo Box Bed Load Capacity	1,250 lb. (567 kg)	1,250 lb. (567 kg)	1,250 lb. (567 kg)	1,250 lb. (567 kg)
Cargo Box Height	11.5 in. (292 mm)	11.5 in. (292 mm)	11.5 in. (292 mm)	11.5 in. (292 mm)
Cargo Box Bed Load Height	33 in. (838 mm)	33 in. (838 mm)	33 in. (838 mm)	33 in. (838 mm)
Dimension				
Length	123.5 in. (3136.9 mm)	155.5 in. (3949.7 mm)	123.5 in. (3136.9 mm)	155.5 in. (3949.7 mm)
Width	64 in. (1625.6 mm)	64 in. (1625.6 mm)	64 in. (1625.6 mm)	64 in. (1625.6 mm)
Height	74 in. (1879.6 mm)	74 in. (1879.6 mm)	74 in. (1879.6 mm)	74 in. (1879.6 mm)
Ground Clearance	10.5 in. (267 mm)	10.5 in. (267 mm)	10.5 in. (267 mm)	10.5 in. (267 mm)
Turning Radius	7.5 ft. (2286 mm)	10.75 ft. (3276 mm)	7.5 ft. (2286 mm)	10.75 ft. (3276 mm)
Features				
Under-Seat Storage	Std	Std	Std	Std
Seat Belt	3-point, retractable	3-point, retractable	3-point, retractable	3-point, retractable
Power Steering	Std	Std	Std	Std
ROPS Approval	Std	Std	Std	Std
Brush Guard	Opt	Opt	Opt	Opt
Hour Meter	Std	Std	Std	Std
Speedometer	Std	Std	Std	Std
Tilt Steering Wheel	Std	Std	Std	Std
Bed Lift	Manual	Manual	Manual	Manual
Frame Type	Steel	Steel	Steel	Steel
Receiver Hitch	2 in.	2 in.	2 in.	2 in.
Headlights				
	Std	Std	Std	Std
Drive System				
Transmission Type	P-R-N-L-H	P-R-N-L-H	P-R-N-L-H	P-R-N-L-H
Traction System	4x4	4x4	4x4	4x4
4WD Selection	Switch	Switch	Switch	Switch
Differential Lock	Switch	Switch	Switch	Switch

*Certain specification(s) are based on engineering calculations and are not actual measurements. Specification(s) are provided for comparison purposes only and are subject to change without notice. Specification(s) for your individual Bobcat equipment will vary based on normal variations in design, manufacturing, operating conditions, and other factors.

WARRANTY

Bobcat Utility Work Machines

Bobcat Company warrants to its authorized dealers and authorized dealers of Bobcat Equipment Ltd., who in turn warrant to the owner, that each new Bobcat utility work machine will be free from proven defects in material and workmanship with respect to (i) all components of the product except as otherwise specified herein for twelve (12) months, (ii) the drive belt from the hydrostatic pump to the engine, for thirty six (36) months, provided that after the initial twelve month warranty period, such warranty shall be limited to parts only and does not include labor, (iii) Bobcat brand tires, for twelve (12) months on a prorated basis based on the remaining depth of the tire at the time any defect is discovered, (iv) Bobcat brand batteries, for an additional twelve (12) months after the initial twelve month warranty period, provided that Bobcat Company shall only reimburse a fixed portion of the cost of replacing the battery during such additional twelve months and (v) auxiliary hydraulic quick couplers for six (6) months or 200 hours, whichever occurs first. For new Bobcat utility work machines sold in the United States or Canada that are equipped with Bobcat Engines, the engine is covered for an additional twelve (12) months after the initial twelve (12) month warranty period, or a total of 2000 hours, whichever occurs first, will apply on machines with a delivery date on or after January 1, 2018. The foregoing time periods shall all commence after delivery by the authorized Bobcat dealer to the original buyer.

During the warranty period, the authorized Bobcat dealer shall repair or replace, at Bobcat Company's option, without charge for parts and labor, any part of the Bobcat product except as otherwise specified herein which fails because of defects in material or workmanship. The owner shall provide the authorized Bobcat dealer with prompt written notice of the defect and allow reasonable time for repair or replacement. Bobcat Company may, at its option, require failed parts to be returned to the factory. Travel time of mechanics and transportation of the Bobcat product to the authorized Bobcat dealer for warranty work are the responsibility of the owner. The remedies provided in this warranty are exclusive.

This warranty does not cover replacement of scheduled service items such as oil, filters, tune-up parts, and other high-wear items. This warranty does not cover damages resulting from abuse, accidents, alterations, use of the Bobcat product with any accessory or attachment not approved by Bobcat Company, air flow obstructions, or failure to maintain or use the Bobcat product according to the instructions applicable to it.

THIS WARRANTY IS EXCLUSIVE AND IN LIEU OF ALL OTHER WARRANTIES AND CONDITIONS, EXCEPT THE WARRANTY OF TITLE. BOBCAT COMPANY DISCLAIMS ALL OTHER WARRANTIES AND CONDITIONS, EXPRESS OR IMPLIED, INCLUDING ANY IMPLIED WARRANTIES OR CONDITIONS OF MERCHANTABILITY OR FITNESS FOR A PARTICULAR PURPOSE. IN NO EVENT SHALL BOBCAT COMPANY OR THE AUTHORIZED BOBCAT DEALER BE LIABLE FOR ANY SPECIAL, INCIDENTAL, INDIRECT OR CONSEQUENTIAL DAMAGES WHATSOEVER, INCLUDING, BUT NOT LIMITED TO, LOSS OR INTERRUPTION OF BUSINESS, LOST PROFITS, OR LOSS OF MACHINE USE, WHETHER BASED ON CONTRACT, WARRANTY, TORT, NEGLIGENCE, STRICT LIABILITY, STATUTE OR OTHERWISE, EVEN IF BOBCAT COMPANY OR THE AUTHORIZED BOBCAT DEALER HAS BEEN ADVISED OF THE POSSIBILITY OF SUCH DAMAGES. THE TOTAL LIABILITY OF BOBCAT COMPANY AND THE AUTHORIZED BOBCAT DEALERS WITH RESPECT TO THE PRODUCT AND SERVICES FURNISHED HEREUNDER SHALL NOT EXCEED THE PURCHASE PRICE OF THE PRODUCT UPON WHICH SUCH LIABILITY IS BASED.



WARRANTY

Bobcat Compact Tractor

Bobcat Company warrants to its authorized dealers and authorized dealers of Bobcat Equipment Ltd., who in turn warrant to the owner, that each new Bobcat Compact Tractor will be free from proven defects in material and workmanship with respect to (i) all components of the product except as otherwise specified herein for twenty four (24) months or 1500 hours (whichever occurs first), (ii) the powertrain components consisting of clutch housing, transmission case, differential and final drive housing and all parts contained therein plus the drive axles and external driveshafts, and the engine components consisting of the crankcase, cylinder head, front gear case, valve cover pans and all parts contained therein but not including fuel, electrical, cooling, intake or exhaust components unless specifically covered under the Emission Control System Warranty for such product, for forty eight months unlimited hours for a tractor sold to a Non-Commercial Customer as specified in the delivery report submitted by the dealer to Bobcat or thirty-six months or 2000 hours (whichever occurs first) for a tractor sold to a Commercial Customer as specified in the delivery report submitted by the dealer to Bobcat, (iii) Bobcat brand tires, for twelve (12) months on a prorated basis based on the remaining depth of the tire at the time any defect is discovered, (iv) Bobcat brand batteries, for twelve (12) months with an additional twelve (12) months provided that Bobcat Company shall only reimburse a fixed portion of the cost of replacing the battery during such additional twelve months and (v) Bobcat accessories that are factory installed for a period of twelve (12) months. The foregoing time periods shall all commence after delivery by the authorized Bobcat dealer to the original buyer.

During the warranty period, the authorized Bobcat dealer shall repair or replace, at Bobcat Company's option, without charge for parts and labor, any part of the Bobcat product except as otherwise specified herein which fails because of defects in material or workmanship. The owner shall provide the authorized Bobcat dealer with prompt written notice of the defect and allow reasonable time for repair or replacement. Bobcat Company may, at its option, require failed parts to be returned to the factory. Travel time of mechanics and transportation of the Bobcat product to the authorized Bobcat dealer for warranty work are the responsibility of the owner. The remedies provided in this warranty are exclusive.

This warranty does not apply to tires (except Bobcat brand tires). The owner shall rely solely on the warranty, if any, of the respective manufacturers thereof. This warranty does not cover replacement of scheduled service items such as oil, filters, tune-up parts, and other high-wear items. This warranty does not cover damages resulting from abuse, accidents, alterations, use of the Bobcat product with any accessory or attachment not approved by Bobcat Company, air flow obstructions, or failure to maintain or use the Bobcat product according to the instructions applicable to it.

THIS WARRANTY IS EXCLUSIVE AND IN LIEU OF ALL OTHER WARRANTIES AND CONDITIONS, EXCEPT THE WARRANTY OF TITLE AND THE EMISSION CONTROL SYSTEM WARRANTY FOR THE PRODUCT. BOBCAT COMPANY DISCLAIMS ALL OTHER WARRANTIES AND CONDITIONS, EXPRESS OR IMPLIED, INCLUDING ANY IMPLIED WARRANTIES OR CONDITIONS OF MERCHANTABILITY OR FITNESS FOR A PARTICULAR PURPOSE. IN NO EVENT SHALL BOBCAT COMPANY OR THE AUTHORIZED BOBCAT DEALER BE LIABLE FOR ANY SPECIAL, INCIDENTAL, INDIRECT OR CONSEQUENTIAL DAMAGES WHATSOEVER, INCLUDING, BUT NOT LIMITED TO, LOSS OR INTERRUPTION OF BUSINESS, LOST PROFITS, OR LOSS OF MACHINE USE, WHETHER BASED ON CONTRACT, WARRANTY, TORT, NEGLIGENCE, STRICT LIABILITY, STATUTE OR OTHERWISE, EVEN IF BOBCAT COMPANY OR THE AUTHORIZED BOBCAT DEALER HAS BEEN ADVISED OF THE POSSIBILITY OF SUCH DAMAGES. THE TOTAL LIABILITY OF BOBCAT COMPANY AND THE AUTHORIZED BOBCAT DEALERS WITH RESPECT TO THE PRODUCT AND SERVICES FURNISHED HEREUNDER SHALL NOT EXCEED THE PURCHASE PRICE OF THE PRODUCT UPON WHICH SUCH LIABILITY IS BASED.



WARRANTY

Bobcat Mini Track Loaders

Bobcat Company warrants to its authorized dealers and authorized dealers of Bobcat Equipment Ltd., who in turn warrant to the owner, that each new Bobcat mini track loader will be free from proven defects in material and workmanship with respect to (i) all components of the product except as otherwise specified herein for twelve (12) months, (ii) the drive belt from the hydrostatic pump to the engine, for thirty six (36) months, provided that after the initial twelve month warranty period, such warranty shall be limited to parts only and does not include labor, (iii) tracks for twelve (12) months on a prorated basis based on the remaining depth of the track at the time any defect is discovered, (iv) Bobcat brand batteries, for an initial twelve (12) month warranty period and for an additional twelve (12) months thereafter, Bobcat Company shall reimburse a fixed portion of the cost of replacing the battery as designated by Bobcat in the event of a proven defect and (v) auxiliary hydraulic quick couplers for six (6) months or 200 hours of use, whichever occurs first. The foregoing time periods shall all commence after delivery by the authorized Bobcat dealer to the original buyer.

During the warranty period, the authorized Bobcat dealer shall repair or replace, at Bobcat Company's option, without charge for parts and labor, any part of the Bobcat product except as otherwise specified herein which fails because of defects in material or workmanship. The owner shall provide the authorized Bobcat dealer with prompt written notice of the defect and allow reasonable time for repair or replacement. Bobcat Company may, at its option, require failed parts to be returned to the factory. Travel time of mechanics and transportation of the Bobcat product to the authorized Bobcat dealer for warranty work are the responsibility of the owner. The remedies provided in this warranty are exclusive.

This warranty does not cover replacement of scheduled service items such as oil, filters, tune-up parts, and other high-wear items. This warranty does not cover damages resulting from abuse, accidents, alterations, use of the Bobcat product with any accessory or attachment not approved by Bobcat Company, air flow obstructions, or failure to maintain or use the Bobcat product according to the instructions applicable to it.

THIS WARRANTY IS EXCLUSIVE AND IN LIEU OF ALL OTHER WARRANTIES AND CONDITIONS, EXCEPT THE WARRANTY OF TITLE. BOBCAT COMPANY DISCLAIMS ALL OTHER WARRANTIES AND CONDITIONS, EXPRESS OR IMPLIED, INCLUDING ANY IMPLIED WARRANTIES OR CONDITIONS OF MERCHANTABILITY OR FITNESS FOR A PARTICULAR PURPOSE. IN NO EVENT SHALL BOBCAT COMPANY OR THE AUTHORIZED BOBCAT DEALER BE LIABLE FOR ANY SPECIAL, INCIDENTAL, INDIRECT OR CONSEQUENTIAL DAMAGES WHATSOEVER, INCLUDING, BUT NOT LIMITED TO, LOSS OR INTERRUPTION OF BUSINESS, LOST PROFITS, OR LOSS OF MACHINE USE, WHETHER BASED ON CONTRACT, WARRANTY, TORT, NEGLIGENCE, STRICT LIABILITY, STATUTE OR OTHERWISE, EVEN IF BOBCAT COMPANY OR THE AUTHORIZED BOBCAT DEALER HAS BEEN ADVISED OF THE POSSIBILITY OF SUCH DAMAGES. THE TOTAL LIABILITY OF BOBCAT COMPANY AND THE AUTHORIZED BOBCAT DEALERS WITH RESPECT TO THE PRODUCT AND SERVICES FURNISHED HEREUNDER SHALL NOT EXCEED THE PURCHASE PRICE OF THE PRODUCT UPON WHICH SUCH LIABILITY IS BASED.



WARRANTY

Bobcat Utility Vehicle

Bobcat Company warrants to its authorized dealers and authorized dealers of Bobcat Equipment Ltd., who in turn warrant to the owner, that each new Bobcat Utility Vehicle will be free from proven defects in material and workmanship with respect to (i) all components of the product except as otherwise specified herein for twelve (12) months or 1000 hours, whichever occurs first and (ii) auxiliary hydraulic quick couplers for six (6) months or 200 hours, whichever occurs first. The foregoing time periods shall all commence after delivery by the authorized Bobcat dealer to the original buyer.

During the warranty period, the authorized Bobcat dealer shall repair or replace, at Bobcat Company's option, without charge for parts and labor, any part of the Bobcat product except as otherwise specified herein which fails because of defects in material or workmanship. The owner shall provide the authorized Bobcat dealer with prompt written notice of the defect and allow reasonable time for repair or replacement. Bobcat Company may, at its option, require failed parts to be returned to the factory. Travel time of mechanics and transportation of the Bobcat product to the authorized Bobcat dealer for warranty work are the responsibility of the owner. The remedies provided in this warranty are exclusive.

This warranty does not apply to non Bobcat branded tires. The owner shall rely solely on the manufacturer's tire warranty, if any. This warranty does not cover replacement of scheduled service items such as oil, filters, tune-up parts, other high-wear items or any damage caused by the use of non-Bobcat fluids and filters. This warranty does not cover accidental damage, air flow obstructions, normal wear and tear, abuse, improper handling, any vehicle that has been altered structurally, modified, neglected, improperly maintained, used for racing, or used for purposes other than for which it was manufactured, or for any damages which occur during trailer transit or as a result of unauthorized service or the use of unauthorized parts. In addition, this warranty does not cover damage to the following items if caused by fire, explosions or any other cause beyond Bobcat's reasonable control: paint or finish, stress cracks, tearing or puncturing of upholstery material or corrosion.

THIS WARRANTY IS EXCLUSIVE AND IN LIEU OF ALL OTHER WARRANTIES AND CONDITIONS, EXCEPT THE WARRANTY OF TITLE. BOBCAT COMPANY DISCLAIMS ALL OTHER WARRANTIES AND CONDITIONS, EXPRESS OR IMPLIED, INCLUDING ANY IMPLIED WARRANTIES OR CONDITIONS OF MERCHANTABILITY OR FITNESS FOR A PARTICULAR PURPOSE. IN NO EVENT SHALL BOBCAT COMPANY OR THE AUTHORIZED BOBCAT DEALER BE LIABLE FOR ANY SPECIAL, INCIDENTAL, INDIRECT OR CONSEQUENTIAL DAMAGES WHATSOEVER, INCLUDING, BUT NOT LIMITED TO, LOSS OR INTERRUPTION OF BUSINESS, LOST PROFITS, OR LOSS OF MACHINE USE, WHETHER BASED ON CONTRACT, WARRANTY, TORT, NEGLIGENCE, STRICT LIABILITY, STATUTE OR OTHERWISE, EVEN IF BOBCAT COMPANY OR THE AUTHORIZED BOBCAT DEALER HAS BEEN ADVISED OF THE POSSIBILITY OF SUCH DAMAGES. THIS EXCLUSION OF SPECIAL, INCIDENTAL, INDIRECT AND CONSEQUENTIAL DAMAGES IS INDEPENDENT FROM AND SHALL SURVIVE ANY FINDING THAT THE EXCLUSIVE REMEDY FAILED OF ITS ESSENTIAL PURPOSE. THE TOTAL LIABILITY OF BOBCAT COMPANY AND THE AUTHORIZED BOBCAT DEALERS WITH RESPECT TO THE PRODUCT AND SERVICES FURNISHED HEREUNDER SHALL NOT EXCEED THE PURCHASE PRICE OF THE PRODUCT UPON WHICH SUCH LIABILITY IS BASED.



Association of Educational Purchasing Agencies
Tabulation Report IFB #020-E - Lawn &
Groundskeeping Equipment, Supplies & Services
Vendor: Husqvarna Professional Products, Inc.

General Comments: Thank you for considering Husqvarna Professional Products in response to IFB #020-E. Please feel free to reach out at any time if there are questions regarding Husqvarna's response, or our capabilities. We look forward to working together.

Best Regards,
Jake Breig
Husqvarna Professional Products
Government Sales Manager, HBD North America
Email- Jake.Breig@husqvarnagroup.com
Work- 704-921-7127
Mobile- 704-340-7367

General Attachments: Exhibit A - Annual Report - Husqvarna Professional Products Inc.pdf
Exhibit B - Marketing Plan - Husqvarna Professional Products.pdf
Exhibit C - Warranties, Additional Services - Husqvarna Professional Products Inc.pdf
Part C - State Signature Forms - Husqvarna Professional Products Inc.pdf
Part D - Questionnaire - Husqvarna Professional Products Inc.pdf
Part E - Signature Forms - Husqvarna Professional Products Inc.pdf
Part F - Pricing Schedule - Husqvarna Professional Products Inc.xlsx

Annual Report on file with CPC/NDESC.



Association of Educational
PURCHASING AGENCIES

Part D - Questionnaire

AEPA IFB 020-E

Lawn & Groundskeeping Equipment, Supplies & Services

Instructions

This questionnaire contains forms and requests for information required by AEPA for vendor evaluation for responsiveness and responsibility.

To submit the required forms, follow these steps:

1. Read the documents in their entirety.
2. Bidders must use Part D – Questionnaire to its capacity. Attached exhibits and/or supplemental information should be included only when requested (i.e. Annual Report, Marketing Plan).
3. Complete all questions.
4. Save all pages in the correct order to a single PDF format titled “**Part D – Questionnaire – Name of Bidding Company**”.
5. Submit Part D, along with other required documents in Public Purchase.

The following sections will need to be completed prior to submission and submitted as one single PDF titled “Part D – Questionnaire – Name of Bidding Company”:

Company Information

Service Questionnaire

Exceptions

Deviations

Company Information

Husqvarna is a world leader in outdoor power products for forestry, lawn and garden care. In the 325 years we have been in business, we have built a brand that is respected by professionals and homeowners alike.

We are the world's largest producer of outdoor power equipment and deliver the widest range of products in the industry – from hand-held products like chainsaws, brush cutters, leaf blowers, and trimmers to our zero turn and robotic mowers. Our professional range of lawn maintenance products are distinguished by solutions that promote productivity, safety and sustainability. High-performance battery-powered products and services such as the Husqvarna Fleet Service™ system are important elements in our commercial lawn and garden segment. We strive to be the preferred partner in the commercial lawn and garden segment, with innovative products and first-class customer service and technical support.

Tree care and forestry are the DNA of the Husqvarna brand and a core pillar of its market and technological leadership. The division continues to innovate, an example of which is the recently launched platform for professional chainsaws which includes the 572 XP® and 550 XP® Mark II models. Both are equipped with Husqvarna's own designed and manufactured saw chain, the best-in-class X-CUT, and digital solutions for the forestry user group.

We are the world leader in robotic mowers, having developed the category more than 20 years ago. Specifically, our recently launched professional robotic All Wheel Drive (AWD) lawn mower will revolutionize the market through its ability to operate on steeper slopes and rougher terrain, further cementing our position as the market and innovation leader in this important segment.

We are growing our digital services. We launched Husqvarna Connect™ to enable consumers to optimize and manage their equipment via a smart phone, and Husqvarna Fleet Services™ to help commercial customers better manage their equipment fleet.

We also offer an assortment of parts and accessories that complement our products to maximize what can be achieved when using our products.

Name of Bidding Company:	Husqvarna Professional Products Inc., a wholly-owned subsidiary of Husqvarna AB (publ), a Swedish corporation
Company Address:	9335 Harris Corners Parkway, Suite 500
City, State Zip code:	Charlotte, NC 28269
Website:	www.husqvarna.com
Contact Person:	Jake Breig
Title:	Government Sales Manager
Phone:	704-340-7367
Email:	Jake.Breig@husqvarnagroup.com

Background

Note: Generally, AEPA will not accept an offer from a business that is less than five (5) years old or, which fails to demonstrate and/or establish a proven record of business. If the bidder has recently purchased an established

business or, has proof of prior success in either this business or a closely related business, provide written documentation and verification in response to the questions below. AEPA reserves the right to accept or reject newly formed companies based on information provided in this response and from its own investigation of the company.

This business is a: public company privately owned company

In what year was this business started under its present name? 1689 (Husqvarna AB); 2007 (Husqvarna Professional Products, Inc.)

Under what additional, or, former name(s) has your business operated? Husqvarna has been doing business in the US commercial lawn and garden space for over 25 years

Is this business a corporation? No Yes. If yes, complete the following:

Date of Incorporation: 12/12/2007

State of Incorporation: Delaware

Name of President: Earl Bennett

Name(s) of Vice President(s): Jill Jacobson (VP, GC & Secretary), Robert Tesch (CFO, VP & Treasurer)

Name of Treasurer: Robert Tesch (CFO, VP & Treasurer)

Name of Secretary: Jill Jacobson (VP, GC & Secretary)

Is this business a partnership? No Yes. If yes, complete the following:

Date of Partnership: _____

State Founded: _____

Type of Partnership, if applicable: _____

Name(s) of General Partner(s): _____

Is this business individually owned? No Yes. If yes, complete the following:

Date of Purchase: _____

State Founded: _____

Name of Owner/Operator: _____

Is this business different from those identified above? No Yes

If yes, describe the company's format, year and state of origin and names and titles of the principles below.

Is this business women owned? No Yes

Is this business minority owned? No Yes

Does this business have an Affirmative Action Plan/Statement? No Yes

The Husqvarna Group provides equal employment opportunities to all individuals without regard to gender, race, religion, age, disability, sexual orientation, gender identity or expression, nationality, social or ethnic origin, citizenship, union affiliation, political opinions or any other characteristics protected by applicable law.

Business Headquarter Location

Business Address 9335 Harris Corners Parkway, Suite 500

City, State Zip code Charlotte, NC 28269

Phone 704-597-5000

How long at this address? Since 2009

Business Branch Location(s)

Branch Address See response below regarding Service/Support and Distribution Centers.

City, State Zip code _____

Branch Address _____

City, State Zip code _____

Branch Address _____
 City, State Zip code _____
 Branch Address _____
 City, State Zip code _____

**If more branch locations exist, insert information here or add another sheet with the above information.*

Sales History

Provide your business's annual sales for 2017, 2018, and 2019 YTD in the United States by the various public segments.

	2017	2018	2019 YTD
K-12 (public & private), Educational Service Agencies	\$278,811	\$295,945	\$134,391
Higher Education Institutions	\$39,993	\$78,419	\$18,901
Counties, Cities, Townships, Villages	\$1.2M	\$6.6M	\$919,220
States	\$2.7M	\$1.5M	\$1.86M
Other Public Sector & Non-profits	\$221,274	\$538,252	\$131,327
Private Sector	> \$1B	> \$1B	> \$1B
Total	> \$1B	> \$1B	> \$1B

Work Force

Key Contacts and Providers: Provide a list of the individuals, titles, and contact information for the individuals who will provide the following services on a national and/or local basis:

Function	Name	Title	Phone	Email
Contract Manager	Michelle Miller	Paralegal	704-921-7113	Michelle.e.miller@husqvarnagroup.com
Sales Manager	Jake Breig	Government Sales Manager	704-340-7367	jake.breig@husqvarnagroup.com
Customer & Support Manager	Freda Smith	Sup. Customer Care & Service	704-921-6971	Freda.Smith@husqvarnagroup.com
Distributors, Dealers, Installers, Sales Reps	Husqvarna currently has over 5,000 authorized dealers across all 50 States. At this time, Husqvarna considers a listing of all of our authorized dealers to be of significant value for our competitors, and we would consider such a list to be highly confidential. To get an idea of our dealer coverage, we have provided a listing of our Husqvarna dealers in the Michigan area. For additional information regarding our dealer coverage, please refer to Husqvarna.com and utilize the 'Where to Buy' function, or we can disclose such list via a separate confidential disclosure.			
Consultants & Trainers	Joyce Kara	Mgr, Commercialization		joyce.kara@husqvarnagroup.com
Technical, Maintenance & Support Services	Michael Ballou	Sr Manager, Customer Care and Service Center	980-250-0530	Michael.ballou@husqvarnagroup.com
Quotes, Invoicing & Payments	Branda Black	Manager, A/R	704-921-6988	Brenda.black@husqvarnagroup.com
Warranty & After the Sale	Servicing dealers who are capable of providing warranty work can be found on Husqvarna.com using the 'Where to Buy' function.			
Financial Manager	Vic Stramenga	Director, Finance	704-921-7148	Victor.stramenga@husqvarnagroup.com

Sales Force: Provide total number and location of salespersons employed by your business in the United States by completing the following: *(To insert more rows, hit the tab key from the last field in the State column.)*

Number of Sales Reps	City	State
11	Charlotte	North Carolina

67	Multiple Locations	Multiple Locations across US

Service/Support and Distribution Centers: Provide the type (service/support or distribution) and location of centers that support the United States by completing the following: *(To insert more rows, hit the tab key from the last field in the State column.)*

Center Type	City	State
Distribution	Charlotte	NC
Distribution	Nashville	AR
Distribution	Shreveport	LA
Distribution	Reno	NV
Distribution	Troy	NY
Distribution	Groveport	OH
Distribution	Dallas	TX
Distribution	Orangeburg	SC
Distribution	Swainsboro	GA
Distribution	West Columbia	SC
Distribution	Blythewood	SC

Marketing

Key Marketing Contact(s): List the name(s), title(s) and contact information of the business's key national and regional marketing office(s). *(To insert more rows, hit the tab key from the last field in the Email column.)*

Name	Title	Phone	Email
Scott Sittler	Marketing Manager	704-921-7128	Scott.sittler@husqvarnagroup.com
Michelle Sordi	VP, Marketing	704-921-6920	Michelle.sordi@husqvarnagroup.com

Marketing Activities: Describe how this business marketed its products and services to schools, nonprofit organizations and other public sector audiences in Fiscal Year 2018- 2019 (July 1 – June 30). List all conventions, conferences and other events at which this company exhibited.

Husqvarna has obtained supply agreements with states via its dealer network. Husqvarna also partners with Earle Kinlaw & Associates, Inc., to market our products/services to federal agencies and said partner annually attends conventions and conferences.

Cooperative Marketing: Describe ways in which this business can collaborate with AEPA Member Agencies in marketing the bid. Submit a marketing plan, titled Exhibit B – Marketing Plan, that would entail at a minimum, the following with their response: process on how the contract will be launched to current and potential agencies, the ability to produce and maintain in full color print advertisements in camera-ready electronic format, including company logos and contact information, anticipated contract announcements, planned advertisements, industry periodicals, other direct or indirect marketing activities promoting the AEPA awarded contract, and how the contract award will be displayed/linked on the Bidder's website.

Please see attached Exhibit B – Husqvarna's Marketing Plan.

Sales Training: Explain how your business will educate your salesforce staff on the AEPA contract including timing, methods, etc.

Husqvarna's salesforce is primarily made up of two segments, which include our territory managers and dealers' sales teams. In order to provide updates and educate the dealers' sales teams, Husqvarna has several forms of media with which we communicate : First, Husqvarna has a Dealer-exclusive portal (Power) that allows dealers to learn about promotions, train on products, and download media/flyers to help drive sales volume. Secondly, Husqvarna hosts regularly scheduled sales calls with our internal staff and dealers' staff to provide updates on new initiatives within the business. Third, Husqvarna regularly sends email communications to our dealer network to provide updates on programs and new activities within the organization. Lastly, each quarter Husqvarna sends print and mailed newsletters to each of our dealers to provide updates on the business. Through each of these communications, Husqvarna would use the opportunity to communicate and train our salesforce on the AEPA contract, upon award.

Environmental Initiatives

Describe how your products and/or services support environmental goals.

1. Husqvarna, between 2015 – 2018, has reduced the carbon footprint of our products by 10% through product efficiency and a broader offering of electric products.
 - a. Specifically, Husqvarna has introduced a line of battery operated Robotic mowers, chainsaws, string trimmers, leaf blowers, pole saws, and hedge trimmers to help this effort.
2. With the Husqvarna Carbon Footprint Calculator, professional landscapers can better understand the CO2 impact of their machine fleet. Via machine sensors and build-in connectivity, the new tool is part of Husqvarna Fleet Services™. It collects data from the machine fleet, tracks equipment performance and identifies ways to improve productivity. The carbon footprint is broken down into application area, product category, engine type and location.
3. Through a pilot program in 2019, we are testing a returnable steel crate for our zero-turn radius (ZTR) ride-on lawn mowers. Two ZTR models available to American and Canadian dealerships will be involved in the pilot. Products will be shipped to the dealers in collapsible crates. They are returned to a refurbishment center where they are repaired and made available for new shipments from our factory in Orangeburg, S.C, USA. The time and effort taken to unload the product is significantly less and the dealer no longer has to dispose of the wood or corrugated packaging. In addition, the solution delivers tangible safety, productivity and shop-floor cleanliness gains.

Describe the business's "green" objectives (i.e. LEED, reducing footprint, etc.).

Information regarding Husqvarna's "green" objectives can be found within our Sustainability Report at <http://www.husqvarnagroup.com/en/sustainability-report>. Below are some highlights that demonstrate Husqvarna's green initiatives.

1. Husqvarna has increased its use of renewable electricity in manufacturing to 86% in 2018 making significant progress towards achieving our 90% target in 2020. One example is the installation of solar panels at our Nashville, AR facility which operates using 25% of its electricity from renewable resources.
2. Husqvarna helps cities achieve their sustainability objectives by cooperating with municipalities on a variety of projects such as the annual Husqvarna Silent City conference that has become an important event to promote green landscaping and to develop more sustainable solutions for professional green space maintenance.
3. Husqvarna plans to exit some low-margin petrol-powered products segments in North America.
4. Husqvarna periodically performs life-cycle assessments on key products.

5. Husqvarna Group has been included in the FTSE4Good Global index and in FTSE4Good Europe Index since 2006. FTSE confirms that Husqvarna Group has been independently assessed according to the FTSE4Good criteria, and has satisfied the requirements to become a constituent of the FTSE4Good Index Series. Companies in the FTSE4Good Index Series have met stringent environmental, social and governance criteria, and are positioned to capitalize on the benefits of responsible business practice.

6. Husqvarna Group has been part of the STOXX® Global ESG Leaders indices since 2014. The STOXX Global ESG Leaders index offers a representation of the leading global companies in terms of environmental, social and governance criteria. STOXX is owned by Deutsche Börse Group and SIX Group.

Independent Subcontractors, Distributors, Installers, etc.

If the Bidder is not the sole provider of all goods and services provided under this contract, the following **must be answered**:

Selection Criteria for Independent Providers: Describe the criteria and process by which the business selects, certifies and approves subcontractors, distributors, installers and other independent services.

Husqvarna selects and maintains partnerships with authorized dealers who are able to satisfy the following qualities.

1. Maintain an inventory of products satisfactory to Husqvarna.
2. Employ sales and service personnel who have attended and completed Husqvarna's training programs for sales and service of products.
3. Within (5) business days after delivery of a product, dealer shall complete warranty registration.
4. Maintain an adequate stock of parts for prompt service and repair of products, and only use parts authorized by Husqvarna for warranty repairs.
5. Maintain a service facility with equipment and tools adequate for effective service and repair of products.
6. Provide operating and safety instructions to purchasers at time of sale.
7. Assemble and test each product before delivery to a customer.

Additionally, Husqvarna verifies our dealer's credit prior to engaging in a partnership.

Current Subcontractors, Distributors, Installers, etc.: Provide a list of current subcontractors, distributors, installers and other independent service providers who are contracted to perform the type of work outlined in this bid in the member agency states (listed in Part A of this IFB). Include, if applicable, contractor license or certificate information and the state(s) wherein they are eligible to provide services on behalf of the business.

Attached is a listing of Husqvarna Dealer's located in the State of Michigan for review. Husqvarna maintains dealer coverage across the United States. As for our other dealers in the US, there is dealer locator information on our website but we consider a complete list of such information to be a trade secret. As a result, Husqvarna can provide a complete list of all of our dealers in the US and their contact information via a separate confidential disclosure upon request.

Disclosures

Line of Credit Letter or Annual Financial Report (REQUIRED): Attach a letter from the business’s chief financial institution indicating the current line of credit available to the business and evidence of financial stability for the past three calendar years (2016, 2017 and 2018). This letter should state the line of credit as a range (i.e. “credit in the low six figures” or “a credit line exceeding five figures”). If company is a publicly traded company a complete Annual Financial Report is required in place of Line of Credit Letter.

Alternatively, Bidders may choose to send the Letter of Line of Credit and/or Annual Report by email directly to the AEPA Executive Director, George Wilson, at georgewilson.aepa@outlook.com. The Letter of Line of Credit and/or Annual Report must be received by the Executive Director before the due date and time of the bid opening.

Legal: Does this business have actions currently filed against it? _____ No Yes

If **Yes**, AN ATTACHMENT IS REQUIRED: List and explain current actions, such as, Federal Debarment (on US General Services Administration’s “Excluded Parties List”), appearance on any state or federal delinquent taxpayer list, or claims filed against the retainage and/or payment bond for projects.

Husqvarna is not involved in any federal debarments, on any state or federal delinquent taxpayer lists or defending claims filed against the retainage and/or payment bond for projects. Husqvarna is involved in legal actions and claims arising in the ordinary course of business, with some legal actions and claims being defended by our insurance carriers and in other instances, we are defending ourselves via outside counsel. We currently believe that each such actions and claims will be resolved without a material effect on our financial condition or business operations.

References

Provide contact information of your business’s five largest public agency customers:

Agency	Name	Title	Phone Number	Email
1. South Carolina Department of Transportation	Tracey Henderson	Kershaw Maintenance	803-432-4358	herdersoTM@SCDOT.ORG
2. Amador Ranger District	Jeff Griffin	Forestry Tech	209-295-5950	jgriffin@fs.fed.us
3. Dept. of the Interior	Chris Rodriguez	Buyer	415-388-3267	Chris_rodriguez@nps.gov
4. Dept. of Agriculture	Nina Donley	Forest Service Buyer	850-926-3561	ndonley@fs.fed.us
5. Onondaga County, NY	Jim Cerio	Director of Building Maintenance and Operations	315-435-3451	jamescerio@ongov.net

Service Questionnaire

The following chart indicates which AEPA Member States intend to participate in this bid category. Respond to Yes/No and choice questions by using an (X). **Note: A Bidder must be willing and able to deliver the proposed products and/or services to 90% of the participating AEPA Member States, unless otherwise stated within Part B Technical Specifications.**

AEPA Member States	Participating in this bid category?	Has the bidding company sold products/services in these states for the past three (3) years? (Yes or No)	If awarded, which states does the bidding company propose to sell in? (Place an X where applicable)	Indicate which states the bidding company has sales reps, distributors or dealers in. (Place an X where applicable)

California	Yes	<u>Yes</u>	<u>X</u>	<u>X</u>
Colorado	Yes	<u>Yes</u>	<u>X</u>	<u>X</u>
Connecticut	Yes	<u>Yes</u>	<u>X</u>	<u>X</u>
Florida	Yes	<u>Yes</u>	<u>X</u>	<u>X</u>
Georgia	Yes	<u>Yes</u>	<u>X</u>	<u>X</u>
Illinois	No	<u>Yes</u>	<u>X</u>	<u>X</u>
Indiana	Yes	<u>Yes</u>	<u>X</u>	<u>X</u>
Iowa	Yes	<u>Yes</u>	<u>X</u>	<u>X</u>
Kansas	Yes	<u>Yes</u>	<u>X</u>	<u>X</u>
Kentucky	Yes	<u>Yes</u>	<u>X</u>	<u>X</u>
Massachusetts	Yes	<u>Yes</u>	<u>X</u>	<u>X</u>
Michigan	Yes	<u>Yes</u>	<u>X</u>	<u>X</u>
Minnesota	Yes	<u>Yes</u>	<u>X</u>	<u>X</u>
Missouri	Yes	<u>Yes</u>	<u>X</u>	<u>X</u>
Montana	Yes	<u>Yes</u>	<u>X</u>	<u>X</u>
Nebraska	Yes	<u>Yes</u>	<u>X</u>	<u>X</u>
New Jersey	Yes	<u>Yes</u>	<u>X</u>	<u>X</u>
New Mexico	Yes	<u>Yes</u>	<u>X</u>	<u>X</u>
North Dakota	Yes	<u>Yes</u>	<u>X</u>	<u>X</u>
Ohio	Yes	<u>Yes</u>	<u>X</u>	<u>X</u>
Oregon	Yes	<u>Yes</u>	<u>X</u>	<u>X</u>
Pennsylvania	Yes	<u>Yes</u>	<u>X</u>	<u>X</u>
Texas	Yes	<u>Yes</u>	<u>X</u>	<u>X</u>
Virginia	Yes	<u>Yes</u>	<u>X</u>	<u>X</u>
Washington	Yes	<u>Yes</u>	<u>X</u>	<u>X</u>
West Virginia	Yes	<u>Yes</u>	<u>X</u>	<u>X</u>
Wisconsin	Yes	<u>Yes</u>	<u>X</u>	<u>X</u>
Wyoming	Yes	<u>Yes</u>	<u>X</u>	<u>X</u>

e-Commerce: Does this business have an e-commerce website? _____ **No** _____ **X** _____ **Yes**
 If YES, what is the website? _____ www.husqvarna.com _____

Customer and Support Service: It is understood depending on the type, kind and level of products and/or services being proposed in response to this bid will impact and determine the type and level of services required and these are identified in Part B Bid Specifications of this IFB.

Does this business have online customer support options? _____ **No** _____ **X** _____ **Yes**
 Does this business have a toll-free customers support phone option? _____ **No** _____ **X** _____ **Yes**
 Does this business offer local customer and support service options? _____ **No** _____ **X** _____ **Yes**

Training: If applicable, does this business offer customer training for the products and services sold? _____ **No** _____ **X** _____ **Yes**

If YES, describe what types/kinds of training you offer, the venues where training occurs and the location(s) of your trainers, include number of staff dedicated to training and their qualifications and hours of operation.

- a. In order to educate and train staff on equipment purchased, Husqvarna will utilize our authorized dealer network as the front line for education and training. Our dealers have been trained on Husqvarna products by our territory managers and product training specialists.
- b. Husqvarna provides different training platforms in order to ensure our dealers have the skills needed to train and service end users. Two of these platforms include:
 1. Certified Technician Training Programs – Each year, Husqvarna’s Technical Training team holds 47 training seminars across the United States for our authorized dealer’s technicians. Upon completion of the training sessions, the dealer’s technicians receive certification for the coursework covered. The technical trainings are used to continue to develop our dealers in order to proactively solve end user’s issues and prevent future issues from occurring.
 2. Husqvarna University – Husqvarna offers an online training program called “Husqvarna University” to all of our dealers and retailers. The platform allows employees within our distribution network to learn and train on Husqvarna product.
- c. Husqvarna also maintains a bilingual YouTube channel that includes a How-To video series. These 15-20 minute videos teach and train users how-to start and operate Husqvarna commercial equipment.
 1. In order to access the YouTube Channel, please visit the following web address <https://www.youtube.com/user/HusqvarnaUSA>

Pricing:

Is your pricing methodology guaranteed for the term of the contract?	_____ No	_____ X	_____ Yes
Will you offer customized price lists to participating entities as required per the pricing terms of Part A?	_____ No	_____ X	_____ Yes
Will you offer hot list pricing (optional) as described in the pricing terms of Part A?	_____ No	_____ X	_____ Yes
Will you offer volume price discounts as described in the pricing terms of Part A?	_____ No	_____ X	_____ Yes

Competitiveness: In order for your bid to be considered, your company must offer AEPA prices that are equal to or lower than those normally offered to individual entities or cooperatives with equal or lower volume.

Is the pricing that is proposed to AEPA equal to or lower than pricing your company offers to individual entities or cooperatives with equal to or lower volume? _____ **No** _____ **X** _____ **Yes**

Indicate which of the following apply and the **level of competitive range** you are offering in response to this IFB.

- _____ **X** Pricing offered to AEPA is EQUAL TO pricing offered to individual customer and/or cooperatives.
- _____ Pricing is LESS THAN individual customer and/or cooperatives. Lower by _____%

Cooperative Contracts: Does your business currently have contracts with other cooperatives (local, regional, state, national)? _____ **No** _____ **X** _____ **Yes**

If YES, identify which cooperative and the respective expiration date(s).

Husqvarna currently holds two state term contracts with the State of South Carolina (Expires May 31st 2023) and the State of North Carolina (Expires August 31st 2020).

If YES, and your business is awarded an AEPA contract, explain which contract your business will lead with in marketing and sales representative presentations (sales calls)?

Because of the coverage of the AEPA contract (28 States, which do not include SC and NC), we will train our sales representatives and dealerships within the 28 states named in the IFB materials to lead with the AEPA Contract. From a marketing standpoint, Husqvarna will create media in partnership with AEPA to help promote use of the contract. Lastly, If Husqvarna is awarded the contract, we will have inside sales resources to begin calling on schools and agencies within the contract territory to promote usage of the contract.

Administrative Fee: Which of the following best reflects how your pricing includes the individual AEPA Members' administrative fee. Mark with an "X".	
X	The pricing for the products and/or services are the same for each AEPA Member Agency, shipping, handling, administrative fee and other specific state costs are added to arrive at total price offered to the Individual AEPA Member Agency.
	The pricing for the products and/or services is inclusive of the administrative fee and therefore the pricing is the same for all AEPA Member Agencies. Shipping, handling and other state specific costs are added to the adjusted AEPA Member Agency's price.
	The pricing for the products and/or services includes ALL (shipping, handling, administrative fee, other) costs to arrive at a single price for all AEPA Member Agencies.

Shipping & Handling: Orders that are \$50.00 or more shall include shipping and handling. What is the flat rate your company will charge, regardless of where shipped in the continental United States, for orders less than \$50.00?	\$ N/A
---	--------

Because of the nature and costs of our products, it is unlikely that Husqvarna will receive an order for less than \$50. Parts, accessories, and service, along with shipping/handling charges, will be quoted through our servicing dealers located across the United States.

Product Returns: Does your business have a return policy? _____ **No** X **Yes**

If YES, describe your return policy and if you charge a restocking fee, what is it? (AEPA allows up to 15% for supplies and up to 25% for equipment).

Please see "How to Obtain Service" and "Returns" within our Warranty Statement attached

Payment Terms: Will your business offer AEPA buyer's a quick pay discount? X **No** _____ **Yes**

If YES, what is the discount? _____ %Net

Leasing: Does your business offer leasing arrangements under this bid? X **No** _____ **Yes**
If Yes, please indicate the rate factor and other cost factors below.

If an AEPA contract is approved and awarded by the Member Agencies, as a Vendor Partner, I agree to:

Responsibilities of an AEPA Vendor Partner	Yes, indicate with an "X"	No, indicate with an "X"
1. Designate and assign a dedicated senior-level contract manager (one authorized to make decisions) to each of the Member Agency accounts. This employee will have a complete copy and must have working knowledge of the AEPA contract.	X	
2. Train and educate sales staff on what the AEPA contract is: including pricing, who can order from the contract (by state), terms/conditions of the contract, and the respective ordering procedures for each state. It is expected that Vendor Partners will lead with AEPA contracts.	X	
3. Develop a marketing plan to support the AEPA contract in collaboration with respective AEPA Member Agencies. The marketing plan should include, but not be limited to, a website presence, electronic mailings, sales flyers, brochures, mailings, catalogs, etc.	X	
4. Create an AEPA-specific sell sheet with a space to add a Member Agency logo and contact information for use by the Member Agencies and the Vendor Partner's local sales representatives to market within each state.	X	
5. On a quarterly basis, complete the sales and administrative fee report (see attached PDF example) and submit to each Member Agency along with the respective administrative fees to be paid. If there are no sales, the Vendor Partner is required to submit a \$0 report to the AEPA Member Agency.	X	
6. Have ongoing communication with the Bid Oversight Chairperson, AEPA Member Agencies and the Member Agencies Participating Entities.	X	
7. Attend two (2) AEPA meetings each year (see Part A)	X	
8. Participate in national and local conference trade shows to promote the AEPA contracts including, but not limited to the Association of School Business Officials (ASBO), the National Institute of Governmental Purchasing (NIGP), and the National Association of Educational Procurement (NAEP).	X	
9. Increase sales over the term of the contract with all participating AEPA Member Agencies.	X	

Deviations

Definition: Deviations can be defined as a major variance, change, or substitution submitted by a Bidder, which deviates from, adds extraneous terms to, conflicts with or offers an alternative to any term, condition, specification or requirement of this solicitation.

Instructions:

1. If “no” is marked with an “X” below, complete this form by signing it at the bottom.
2. If “yes” is marked with an “X” below, insert answers into the form shown below, providing narrative explanations of deviations. *(To insert more rows, hit the tab key from the last field in the last row and column.)*
3. If adding pages, the bidder’s name and identifying information as to which item the response refers must appear on each page.
4. Deviations to local, state or federal laws cannot be accepted under this bid.

	No , this bidder does not have deviations (exceptions or alternates) to the specifications listed in Part B of this IFB.
X	Yes , this bidder has the following deviations to the specifications listed in Part B of this IFB. See Deviations Attachment

Outline Number Part B	Specification (describe)	Details of Deviation
Part A Section V.	Audit Rights	Add at the end: “upon reasonable notice”
Part A Section V.	The title and risk of loss of material or service	Change to read as follows: “shall not pass to the Buyer purchasing the material or services until it actually receives the material or service at the point of delivery (FOB Destination) and they have been accepted (which shall occur upon expiration of a reasonable inspection period and Buyer either (1) fails to reject the product before expiration of said period or (2) Buyer uses the Product, unless otherwise provided within this document or individual project’s contract.”
Part A Section V.	Shipping Terms	6 th line, insert after “Partner”: “or one of its authorized dealers, as applicable,”
Part A Section V.	Shipping Terms	7 th line, insert after “Partner”: “, its authorized dealer,” 8 th line, change: “freight company/Vendor Partner” to “freight company, Vendor Partner or its authorized dealer”
Part A Section V.	Liquidated Damages	Replace 2 nd sentence with: “The Vendor Partner (if applicable Surety) may be liable for and shall pay to the Buyer, not as a penalty, the sums that may be hereinafter mutually agreed by the Vendor Partner and Buyer upon as liquidated damages per calendar day of delay until the work and/or delivery is determined by Buyer to be complete and/or delivered.
Part A Section V.	Indemnification	2 nd line, insert after “all”: “third party” 4 th line: Delete “or incurred by” 12 th line: Delete “sole” Add at the end: “AEPA, its Members, Participating Entities and its employees shall reasonably notify Vendor Partner of any claim

		for which it, its' employees, agents, representatives or authorized dealer and their respective employees, agents or representatives may be liable under this paragraph."
Part A Section V.	Insurance	2 nd sentence, add after "firm": "or if insured by a captive insurer, said insurer,".
Part A Section V.	Licenses and Registrations	Last sentence, insert after "will": ", upon request from individual jurisdictions,"
Part A Section V.	Special Ordering Procedures	c. insert after "Vendor Partner": "or its authorized dealer,"
Part A Section V.	Pricing	1 st paragraph, 7 th line, insert after "any": "Participating"
Part A Section V.	Quality	Change at the end to read: "and confirm to the written promises and/or oral affirmations of fact made by Vendor Partner" to "confirm to the written warranty included with this bid submittal."
Part A Section V.	Termination for Default	2 nd No. 2, insert after "another": "Participating Entity"
Part B	8.2	Vendor Partner will exercise commercially reasonable efforts to maintain a minimum monthly overall average fill rate of 95% or above.
Part B	8.6	Vendor Partner can provide a detailed list of its authorized dealers and any and all their associated costs via a separate confidential disclosure with each Buyer upon request.
Part B	Pricing	7 th line, insert after "individual": "participating"

Dealer/Retailer	Area Code	Phone Number	Street Address	City	State	Zip Code	Email Address
AGARD LAWN & GARDEN LLC	231	728-0170	150 OTTAWA	MUSKEGON	MI	49442	
BACKWOODS PRODUCTS	231	462-3934	3874 E. MANALES ROAD	FOUNTAIN	MI	49410	
DUPUIE'S SMALL ENGINE REPAIR	231	258-5771	1053 M-72 SE	KALKASKA	MI	49646	JDUPUIE@GT11.COM
EBEL'S HARDWARE INC	231	826-3333	420 PROSPER ROAD	FALMOUTH	MI	49632	EBELS@NETONECOM.NET
FAIRVIEW HARDWARE, INC.	989	848-2700	1509 NORTH ABBE ROAD	FAIRVIEW	MI	48621	DOIT@FAIRVIEWHARDWARE.COM
JARVIS SAWMILL, INC	231	861-2078	1570 SOUTH 112TH AVE.	SHELBY	MI	49455	
GLEASON SALES & SERVICE	231	745-3053	11581 NORTH WOODBRIDGE	BITELY	MI	49309	
LARK LAWN & GARDEN	231	943-4900	4037 NORTON ROAD	GRAWN	MI	49637	LARK4037@AOL.COM
MCLEAN'S PRO MART	989	348-2931	209 SOUTH JAMES	GRAYLING	MI	49738	VMCLEAN@FREEWAY.NET
ROTHBURY HARDWARE & FARM SUPPLY	231	894-8590	7612 MICHIGAN ST.	ROTHBURY	MI	49452	ROTHHDW@CORE.COM
SEYMOUR'S SALES & SERVICE	231	843-9157	5273 W. HESSLUND ROAD	LUDINGTON	MI	49431	SEYMOUR@T-ONE.NET
SPARR MALL	989	732-9140	4991 SPARR ROAD	GAYLORD	MI	49735	
STATE STREET HARDWARE	231	796-8122	614 N STATE ST	BIG RAPIDS	MI	49307	
GRIND-DING SHOP	989	727-3449	6050 HERRON ROAD	HERRON	MI	49744	THEGRINDINGSHOP@SPEEDNETLLC.COM
TILMANN HARDWARE, INC.	989	644-5161	1963 NORTH WINN ROAD	MT. PLEASANT	MI	48858	MARGARET_SIMMER@CMSINTER.NET
WILLARD'S EQUIPMENT	989	345-3128	255 SOUTH M-33	WEST BRANCH	MI	48661	
AREA CYCLE	989	777-0850	7482 DIXIE HWY	BRIDGEPORT	MI	48722	
PAT MEYERNG	616	916-4792	7374 KENOWA AVE	BYRON CENTER	MI	49315	
MATT ORR			2000 HIGH POINT COURT	MARQUETTE	MI	49855	
UNCLAIMED FREIGHT STORE	989	893-3531	706 EAST MIDLAND	BAY CITY	MI	48706	TDODICK@AOL.COM
BALL EQUIPMENT	586	430-1252	68811 S MAIN ST	RICHMOND	MI	48062	BALLSAND@GREATLAKES.NET
REX BINDER SALES	989	673-4367	1264 E. CARO ROAD	CARO	MI	48723	
CHAIN SAW PLUS	616	534-9901	3781 28TH ST. S.W.	GRANDVILLE	MI	49418	CHAINSAWSPLUS@MCLEODUSA.COM
DENNY'S SAW CRIB	269	388-3795	646 EAST VINE STREET	KALAMAZOO	MI	49001	
J & S REPAIR	810	664-7270	2023 N LAPEER RD	LAPEER	MI	48446	
JOHN'S PLACE	586	752-5599	8175 30 MILE ROAD	WASHINGTON	MI	48095	
LARRY'S CUSTOM CYCLE	517	263-5140		ADRIAN	MI	49221	
M-C SUPPLY	269	945-2783	2310 S M37	HASTINGS	MI	49058	PARTS@MCSUPPLY.COM
MANIUS POWER MOWERS	248	549-2440	30642 WOODWARD	ROYAL OAK	MI	48073	
MARK'S OUTDOOR POWER EQUIPMENT	248	349-3860	16959 NORTHVILLE RD.	NORTHVILLE	MI	48168	MKINGMI@COMCAST.NET
PERFORMANCE AUTOMOTIVE	517	789-7151	2710 AIRPORT ROAD	JACKSON	MI	49202	PERFORMANCAUTO040@SBCGLOBAL.NET
SAW SHACK	269	965-8591	954 EAST EMMETT	BATTLE CREEK	MI	49014	ES0774@HOTMAIL.COM
UNITED MOWER	248	474-4325	28619 GRAND RIVER	FARMINGTON HILLS	MI	48336	
WOLVERINE EQUIPMENT	734	779-9220	26423 HARPER	ST. CLAIR SHORES	MI	48081	
JIM'S OUTDOOR POWERLAND	269	657-3368	37704 RED ARROW	PAW PAW	MI	49079	
OWEN TREE SERVICE, INC.	810	724-6651	225 N LAKE GEORGE RD	ATTICA	MI	48412	TMURPHY@WENTREE.COM
DEER CREEK SALES, INC.	517	655-1788	1540 LINN RD.	WILLIAMSTON	MI	48895	
FISH & HUNT SHOP	906	586-9531	W17148 MAIN STREET	CURTIS	MI	49820	MICKG@FISHANDHUNTSHOP.COM
GREAT LAKES WOOD PRODUCTS	906	228-3737	434 US HIGHWAY 41 EAST	NEGAUNEE	MI	49866	GLWP37@CHARTERMI.NET
WANINK SERVICE & SALES	906	224-7581	1 WANINK ROAD	WAKEFIELD	MI	49968	
LUND'S SERVICE	906	341-5761	839N ASH ROAD	MANISTIQUE	MI	49854	
PM SMALL ENGINE SERVICE	906	293-3177	9499 N CITY RD 405	NEWBERRY	MI	49868	
SKINNER'S GARAGE	906	647-5655	4142 PLEASANT AVE.	PICKFORD	MI	49774	SKINNERS@SAWT.COM

KIILINEN REPAIR	906 296-1321	928 9TH STREET	LAKE LINDEN	MI	49945	
HONKALA'S SERVICE	906 486-8203	32975 COUNTY ROAD 581	ISHPEMING	MI	49849	HONKALAS@CHARTER.NET
BERNARD'S HARDWARE						
COMPANY	616 897-9490	1601 W. MAIN ST.	LOWELL	MI	49331	BERNARDSHDWE@AOL.COM
PIPESTONE SMALL ENGINE	269 461-6421	4947 PARK ROAD	EAU CLAIRE	MI	49111	PIPESTONE@SBCGLOBAL.NET
ROUGH OUTDOOR EQUIPMENT	269 244-5969	56653 ABBEY ROAD	THREE RIVERS	MI	49093	
K & C CHAPARRAL	989 876-7816	2466 S. U.S. 23	AU GRES	MI	48703	
STUDZ HARDWARE, INC.	313 563-1058	4457 S. TELEGRAPH RD.	DEARBORN HEIGHTS	MI	48125	
ROY'S GENERAL STORE & HARDWARE	231 947-6810	963 HAMMOND RD. E	TRAVERSE CITY	MI	49686	ROYSSERVICECENTER@CHARTERINTERNET.COM
TIMBERLAND EQUIPMENT	231 689-5607	6245 E. 36TH ST.	WHITE CLOUD	MI	49349	
ATHERTON ROAD SALES	810 743-7776	6468 EAST ATHERTON RD	BURTON	MI	48519	JOHN@ATHERTONROAD.COM
TOM'S SMALL ENGINE	517 439-9472	24 DIVISION ST.	HILSDALE	MI	49242	
ALLENDALE TRUE VALUE	616 895-5400	5425 LAKE MICHIGAN DRIVE	ALLENDALE	MI	49401	ATVH@ALTELCO.NET
SHARP SHOP	269 345-8831	3638 LAKE	KALAMAZOO	MI	49001	
RUNNIN GEARS	989 539-5540	2500 MAJOR MOUNTAIN RD.	HARRISON	MI	48625	
HEALY TRUE VALUE	269 628-2584	307 SOUTH STATE	GOBLES	MI	49055	
STARK'S SERVICE & HARDWARE	586 468-2570	328 CASS AVE	MOUNT CLEMENS	MI	48043	KSTARK6@YAHOO.COM
COUNTRYSIDE LAWN & POWER EQUIP. INC	517 641-7379	14770 WEBSTER RD.	BATH	MI	48808	
POWERS ACE HARDWARE	231 448-2572	26259 MAIN STREET	BEAVER ISLAND	MI	49782	
PARKER LUMBER & HARDWARE, INC.	906 632-3201	819 ASHMUN	SAULT SAINT MARIE	MI	49783	
NORTHGATE EQUIPMENT & SALES	906 789-9812	6687 HWY 2, 41 & M35	ESCANABA	MI	49829	NORTHGATE@CHARTERMI.NET
STEENSMA LAWN & POWER, INC.	269 375-6476	7561 STADIUM DRIVE	KALAMAZOO	MI	49009	
HAGLUND'S ALL OUTDOORS LLC	989 724-5599	4999 EAST M-72	HARRISVILLE	MI	48740	HAGLUNDLANDSCAPING@KWCOM.NET
JOE'S LAWN N' GARDEN	269 673-8736	1141 26 ST	ALLEGAN	MI	49010	
GRAND RENTAL STATION	269 279-6041	58904 US 131	THREE RIVERS	MI	49093	
REEMAN FARM EQUIPMENT, INC. DBA	231 924-2570	7180 WEST 48TH STREET	FREMONT	MI	49412	
WOLVERINE HARDWARE	269 637-1915	530 HURON STREET	SOUTH HAVEN	MI	49090	
ST IGNACE TRUE VALUE	906 643-7979	300 S STATE STREET	ST IGNACE	MI	49781	SITRUVAL@UP.NET
HARDWARE						
REINDEL TRUE VALUE						
HARDWARE	586 293-3180	32916 UTICA ROAD	FRASER	MI	48026	
GLADWIN PRO FARMERS						
SUPPLY DBA	989 426-4549	645 N. STATE	GLADWIN	MI	48624	
MOORE & CARTER LBR/DO IT BEST	810 679-3494	5220 E. PECK ROAD	CROSSWELL	MI	48422	
DO-IT-BEST/WARDS RENTAL CENTER	810 231-7368	6472 EAST M-36	HAMBURG	MI	48139	
PAIDL'S DO IT BEST	906 753-1087	N8077 US HWY 41	STEPHENSON	MI	49887	
WARD'S HUSQVARNA SALES & SERVICE	906 482-6255	48602 M-26	DOLLAR BAY	MI	49922	

ACE HARDWARE & SPORTING GOODS	906 643-7721	7 COUTH STATE ST	ST. IGNACE	MI	49781	IRVINSHWI@DMCI.NET
IRVINS HARDWARE & AUTO	517 568-4441	114 EAST MAIN ST	HOMER	MI	49245	CAS@UP.NET
HALL'S HARDWARE	906 563-9553	544 MAIN STREET	NORWAY	MI	49870	
KERR HARDWARE	517 676-5040	222 S. CEDAR	MASON	MI	48854	
CHOCOLAY ACE HARDWARE	906 249-2223	2250 US 41 SOUTH	MARQUETTE	MI	49855	CHOCOLAYACE@CHARTERMI.NET
MC LEAN'S RENT-IT-CENTER/DO IT-BEST	231 258-9141	109 EAST OAK STREET	KALKASKA	MI	49646	
FAMILY FARM & HOME CORP.	517 279-0461	4325 PLAINFIELD NE	GRAND RAPIDS	MI	49525	
CEDAR CYCLE	616 696-5141	91 W ASH STREET	CEDAR SPRINGS	MI	49319	
GRAND RENTAL STATION/TRU-SERVE	616 866-7670	3575 14 MILE ROAD	CEDAR SPRINGS	MI	49319-9117	
XYZ LANDSCAPE SUPPLY	989 288-4600	8800 E LANSING ROAD	DURAND	MI	48429	XYZ@SHIANET.ORG
RALPH'S LAWN EQUIPMENT SALES	734 676-2000	8220 MACOMB STREET	GROSSE ILE	MI	48138	RALPHS.LAWN.EQUIP@SBCGLOBAL.NET
DO-IT-BEST/MARTINS HARDWARE	810 742-6910	5516 E ATHERTON	BURTON	MI	48519	
CEM SUPPLY	517 278-2611	178 W GARFIELD ROAD	COLDWATER	MI	49036	
O K INDUSTRIAL SUPPLY/DO IT BEST	906 486-4489	605 ELM STREET	ISHPEMING	MI	49849	
HALE HARDWARE	989 728-9581	115 SOUTH WASHINGTON	HALE	MI	48739	
WARNER SUPPLY	269 628-6400	33310 M 43 HWY	PAW PAW	MI	49079	
TED'S HOME & LAWN, INC.	989 839-9700	756 POSEVILLE ROAD	MIDLAND	MI	48640	
CONTRACTOR'S REPAIR	517 339-5709	13612 WOODBURY ROAD	HASLETT	MI	48840	CONREP@TDS.NET
REINBOLD'S SALES & SERVICE	989 755-0612	110 N GERA ROAD	REESE	MI	48757	REINBOLDSALES@AIRADV.NET
MAZZETTI & ASSOCIATES	586 757-7477	24832 ROMANO AVENUE	WARREN	MI	48091	PMAZZETTITJR@YAHOO.COM
BOLEMA LUMBER COMPANY	231 773-3391	1230 E LAKETON AVENUE	MUSKEGON	MI	49442	
WAYLAND HARDWARE	269 792-2801	415 RENO DRIVE	WAYLAND	MI	49348	
RAYMOND HARDWARE # 03901-6	810 622-9991	29 SOUTH RIDGE STREET	PORT SANILAC	MI	48469	
BALDWIN ACE HARDWARE #10975	231 745-4511	6785 SOUTH M-37	BALDWIN	MI	49304	
TAWAS HARDWARE INC #1322	989 362-3821	108 LAKE ST	TAWAS CITY	MI	48763	
JUDD LUMBER CO	269 782-5134	101 ROBINSON ST	DOWAGIAC	MI	49047	
DUBOIS LUMBER CO	989 348-4831	6593 WEST M-72	GRAYLING	MI	49738	
MAGIC CITY HARDWARE	269 432-3464	130 E. STATE ST.	COLON	MI	49040	
ERICKSON TRUE VALUE #11843-5	906 524-6295	US 41	L'ANSE	MI	49946	
HASLETT TRUE VALUE	517 339-2829	1581 HASLETT	HASLETT	MI	48840	
DUNDEE ACE HARDWARE	734 529-5023	545 EAST MONROE	DUNDEE	MI	48131	
HEDMARK SALES & SERVICE	906 942-7345	155 TOWNHALL RD	SKANDIA	MI	49885	
DERONNE TRUE VALUE	586 779-5000	18561 NIN MILE	EASTPOINTE	MI	48021	
SUPERIOR SAW	517 694-2266	1334 N. CEDAR ST.	MASON	MI	48854	
DAN'S OUTDOOR POWER PRODUCTS	906 265-5381	500 HOMER RD	IRON RIVER	MI	49935	
DICK COULTER, INC.	810 688-3083	6672 LK. PLEASANT RD	NORTH BRANCH	MI	48461	
CARPENTER BROS. HARDWARE	734 663-2111	2753 PLYMOUTH RD	ANN ARBOR	MI	48105	
VAN'S SPORTS CENTER	616 364-0666	1855 ALPINE N.W.	GRAND RAPIDS	MI	49504	

LEWISTON HARDWARE & LUMBER	989 786-2388	4421 HANSON	LEWISTON	MI	49756
GALE'S TRUE VALUE	269 342-8111	2825 STADIUM DRIVE	KALAMAZOO	MI	49008
LANDERS HARDWARE, INC.	269 427-7247	609 W. MONROE ST.	BANGOR	MI	49013
HARRINGTON'S	517 646-8787	10895 VERMONTVILLE HWY	DIMONDALE	MI	48821
J & J FARM SALES & SERVICE	231 744-7140	4241 HOLTON RD	NORTH MUSKEGON	MI	49445
GILL-ROYS HARDWARE	810 658-2288	8405 DAVIDSON ROAD	DAVISON	MI	48423
BYWATER'S OUTDOOR POWER	989 834-5511	9055 EAST M 21	OVID	MI	48866
GREGOIRE & DODICK ACE	989 893-3531	706 E MIDLAND ST	BAY CITY	MI	48706
DARRELL'S MARKET & HARDWARE	517 676-5225	4520 W. COLUMBIA RD	MASON	MI	48854
NAGY'S TRACTOR SALES, INC.	989 653-3173	1980 W. US-23	OMER	MI	48749
POINT RENTAL & SALES	517 849-9770	4130 BECK RD	JONESVILLE	MI	49250
COUNTRY VILLAGE ACE HARDWARE	906 485-4686	1150 COUNTRY LANE	ISHPEMING	MI	49849
MATTSON TRUE VALUE #02550-2	231 937-4381	223 S. ENSLEY ST.	HOWARD CITY	MI	49329
VERNON TRUE SERVE	989 288-5411	7200 M 71 BOX 210	VERNON	MI	48476
LYNCH'S MOTOR SPORTS	810 987-6100	5386 LAPEER ROAD	KIMBALL	MI	48074
WESTBROOK HARDWARE	810 679-3440	76 N HOWARD AVE	CROSWELL	MI	48422
A & G HARDWARE	248 852-5330	1927 W. AUBURN ROAD	ROCHESTER HILLS	MI	48309
BEAR LAKE SUPPLY	231 864-3036	11950 CHIPPEWA HWY	BEAR LAKE	MI	49614
BOB'S TRUE VALUE HARDWARE	269 694-4855	125 W ALLEGAN STREET	OTSEGO	MI	49078
GILBERT DO IT BEST	989 723-2330	12900 S US 27 SUITE 11	DEWITT	MI	48820
VILLAGE LUMBER & SUPPLY	616 374-8944	1019 FIRST ST	LAKE ODESSA	MI	48849
MERCHANTS TRUE VALUE					
#00050-5	517 741-4355	205 NORTH BROADWAY	UNION CITY	MI	49094
GARY'S LAWN & GARDEN	269 685-6775	742 112TH	MARTIN	MI	49070
BOYNE CO-OP	231 582-9971	113 S. PARK ST	BOYNE CITY	MI	49712
HALE'S TRUE VALUE & RADIO					
SHACK	269 782-3426	56216 M-51 SOUTH	DOWAGIAC	MI	49047
DON'S AIR COOLED INC	734 587-2319	10806 TORREY RD	WILLIS	MI	48191
TJ'S RENT-ALL LLC	989 856-4404	6832 MAIN ST	CASEVILLE	MI	48725
TOOL SHED/MIDWAY SALES	269 651-3267	401 ST. JOSEPH ST	STURGIS	MI	49091
JACKSON OUTDOOR EQUIPMENT LLC	517 782-3319	3481 PAGE AVE	JACKSON	MI	49203
TC'S DO IT BEST HARDWARE #0770	517 467-2131	108 MAIN ST	ONSTED	MI	49265
MICHIGAN SERVICE CENTER	989 624-9305	8074 MAIN ST	BIRCH RUN	MI	48415
BILLINGS FEED STORE INC	248 541-0138	1241 W. 14 MILE RD	CLAWSON	MI	48017
SOMERSET OUTDOORS	517 688-9077	10449 CHICAGO RD	JEROME	MI	49249
MOBILE MOWER REPAIR INC	734 426-5665	1535 BAKER ROAD	DEXTER	MI	48130
GREAT LAKES DOCKS & DECKS	586 725-0009	7427 DYKE ROAD	ALGONAC	MI	48001
MIO ACE HARDWARE	989 826-360	103 E 8TH STREET	MIO	MI	48647
PRO MOWER & SNOW	586 754-7009	11566 TIMKEN	WARREN	MI	48089
BAKER'S ACE HARDWARE #14255	734 241-8959	903 NORTH DIXIE HWY	MONROE	MI	48162
KENT POWER EQUIPMENT	616 675-5368	1550 10 MILE RD	SPARTA	MI	49345
HOPPS TRUE VALUE #13765-6	989 843-6667	408 OHMER RD	MAYVILLE	MI	48744

H & B EQUIPMENT INC	989	781-2337	7901 GRATIOT RD	SAGINAW	MI	48609	
EDMORE SAW & LAWN	989	427-3300	79E HOWARD CITY-EDMORE RD	EDMORE	MI	48829	
TAYLOR RENTAL #14697-0	231	347-1840	1888 E MITCHELL	PETOSKEY	MI	49770	
MARK SOUDER - DEMO	989	302-1116	141 QUESTVIEW DRIVE	HOUGHTON LAKE	MI	48629	
GREEN ACE HOME CENTER	989	345-0020	2106 S. M-76	WEST BRANCH	MI	48661	
ACE HARDWARE	517	676-4900	340 S CEDAR	MASON	MI	48854	
BERNARD'S ACE HARDWARE	616	897-9490	1601 W MAIN ST	LOWELL	MI	49331	
PARKER ACE HARDWARE	906	632-3201	819 ASHMIN STREET	SAULT SAINTE MARIE	MI	49783	
MEYER ACE HARDWARE	231	347-7390	1371 US 31 NORTH	PETOSKEY	MI	49770	
STONE'S ACE INC	586	416-0088	41400 HAYES ROAD	CLINTON TOWNSHIP	MI	48038	
BAKER'S ACE HARDWARE	734	241-8974	905 N. DIXIE HIGHWAY	MONROE	MI	48162	
GEMMEN'S DO IT BEST RENTAL	616	669-1118	3488 KELLY STREET	HUDSONVILLE	MI	49426	
DARLING HARDWARE	517	625-3070	156 N MAIN ST	PERRY	MI	48872	
VAN WIEREN HARDWARE INC			645 DOUGLAS AVE	HOLLAND	MI	49424	
HARRISON LUMBER DO IT HWI			201 E. BEECH	HARRISON	MI	48625	
LATHAM'S DOWNTOWN HARDWARE INC.			37 WEST MAIN STREET	MILAN	MI	48160	
A & J HARDWARE	269	422-2489	1745 W. SHAWNEE ROAD	BARODA	MI	49101	
HUNT'S HARDWARE	231	893-6945	115 E. COLBY ST	WHITEHALL	MI	49461	
BROWN'S DO-IT CENTER	810	636-6660	7281 SO. STATE RD	GOODRICH	MI	48438	
WARDS DO-IT CENTER			6472 EAST M36	HAMBURG	MI	48139	
STURGIS INDUSTRIAL SUPPLY	616	651-4444	504 NORTH NOTTAWA	STURGIS	MI	49091	
DUBOIS LUMBER COMPANY	989	348-4831	609 NORWAY ST	GRAYLING	MI	49738	
MANCELONA DO IT BEST	231	587-9197	558 WEST STATE ST	MANCELONA	MI	49659	
ROSENBERG TRUE VALUE							
#00316-0	231	689-1001	1164 E WILCOX AVE	WHITE CLOUD	MI	49349	
KINGSLAND ACE HARDWARE	616	949-1240	6579 28TH ST. S.E.	GRAND RAPIDS	MI	49546	
GRAND RENTAL STATION							
#01841-6	231	843-1504	5061 WEST US 10	LUDINGTON	MI	49431	
JEAN'S TRUE VALUE							
HARDWARE #02077-6	248	626-2828	29950 W 12 MILE RD	FARMINGTON	MI	48334	
LIVONIA TRUE VALUE							
HARDWARE	734	422-1155	33533 5 MILE RD	LIVONIA	MI	48154	
OCEANA BUILDERS SUPPLY							
#02313-5	231	861-2136	3053 S OCEANA DR	SHELBY	MI	49455	
GRAND RENTAL STATION							
#13475-2	269	279-6041	58904 US #131	THREE RIVERS	MI	49093	
GRAND RENTAL CENTER #13501							
5	989	686-2741	1109 SALZBURG AVE	BAY CITY	MI	48706	
1AVIT SUPPLIES WEST #13665-8	616	726-6864	2830 LOCKE AVE	GRANDVILLE	MI	49418	
HAVEMAN HARDWARE	616	924-3320	29 WEST MAIN	FREMONT	MI	49412	
TAYLOR RENTAL CENTER							
#13775-5	616	392-8539	62 WAVERLY STREET	HOLLAND	MI	49423	
TAYLOR RENTAL CENTER							
#14155-9	269	925-2125	2524 M139 HWY	BENTON HARBOR	MI	49022	
SCOOTERS TRUE VALUE #15136-							
8	616	964-0174	912 NORTH AVE	BATTLE CREEK	MI	49017	

FIFE LAKE TRUE VALUE HARDWARE	231 879-4287	119 STATE STREET	FIFE LAKE	MI	49633	
ED BOCK FEEDS	734 878-3092	1360 E-W36	PINCKNEY	MI	48169	
KINGSFORD ACE	906 776-6000	555 S. CARPENTER AVE	KINGSFORD	MI	49802	
HOLLAND ACE HARDWARE	616 392-5901	835 LINCOLN AVE	HOLLAND	MI	49423	
NORTHSHORE ACE HARDWARE	231 744-1280	605 WHITEHALL ROAD	NORTH MUSKEGON	MI	49445	
RENTAL EXPRESS	231 238-9696	1430 S. STRAIT'S HWY	INDIAN RIVER	MI	49749	
BARON HARDWARE & AUTO	517 369-4175	119 E. CHICAGO ST	BRONSON	MI	49028	
NOVAK SUPPLY & EQUIPMENT, INC.	810 798-8533	3620 VAN DYKE	ALMONT	MI	48003	
QUALITY HARDWARE	906 296-9122	200 CALUMET ST	LAKE LINDEN	MI	49945	
WEINGARTZ SUPPLY CO. INC.	586 731-7240	46061 VAN DYKE	UTICA	MI	48317	
WHEELS & BLADES INC	248 363-6683	8055 COMMERCE	COMMERCE	MI	48382	
ALL SEASONS OUTDOOR EQUIPMENT	586 771-4949	15130 EAST TEN MILE ROAD	EASTPOINTE	MI	48021	
WESTLAND LAWN & SNOW	734 261-1250	27429 JOY ROAD	WESTLAND	MI	48185	
WEINGARTZ	248 471-3050	39050 GRAND RIVER	FARMINGTON HILLS	MI	48335	
HELLEBUYCKS BIKE & MOWER	586 739-9620	52881 VAN DYKE	UTICA	MI	48316	
WEINGARTZ SUPPLY CO-						
WATERFORD	248 623-4731	5395 DIXIE HWY	WATERFORD	MI	48329	
PACE, INCORPORATED	734 453-6258	5850 ALDER AVE	SACRAMENTO	CA	95828	
RON'S OUTDOOR POWER EQUIPMENT	231 465-4444	841 S CHESTNUT	REED CITY	MI	49677	
DICK'S LAWN EQUIPMENT	248 363-1029	7215 COOLEY LAKE RD	WEST BLOOMFIELD	MI	48324	
ROCHESTER LAWN EQUIPMENT						
CENTER INC	248 852-4961	94 W. AUBURN ROAD	ROCHESTER HILLS	MI	48307	
WAYNE LAWN & GARDEN						
CENTER INC	734 721-5220	39915 MICHIGAN AVE	CANTON	MI	48188	
DAMM'S INC.	989 453-2531	7287 MICHIGAN AVE	PIGEON	MI	48755	
BOURLIERS INC.	586 792-6300	35850 ITTICA ROAD	CLINTON TOWNSHIP	MI	48035	
CALEDONIA RENT-ALL, INC.	616 891-0050	9800 CHERRY VALLEY AVE	CALEDONIA	MI	49316	
PETER'S TRUE VALUE						
HARDWARE	248 887-7795	3455 WEST HIGHLAND ROAD	MILFORD	MI	48380	
VASSAR TRUE VALUE						
HARDWARE	989 823-7651	402 E HURON AVE	VASSAR	MI	48768	
LARRY'S MOWER SHOP	734 994-6555	5040 JACKSON RD	ANN ARBOR	MI	48103	
MEYER TRUE VALUE						
HARDWARE	231 347-3978	1371 US 31 NORTH	PETOSKEY	MI	49770	
WM F SELL & SON, INC.	734 692-5100	25151 ALLEN RD	WOODHAVEN	MI	48183	
AUTO VALUE OF L'ANSE	906 524-7281	725 E. BROAD ST.	L'ANSE	MI	49946	
RENZE POWER SPORTS	906 389-3920	E9550 PROSPECT ST	MUNISING	MI	49862	CHUCK@RENZEPOWERSPORTS.COM
ORTONVILLE ACE HARDWARE	248 627-9217	440 N. ORTONVILLE	ORTONVILLE	MI	48462	
TOTAL TOOL & EQUIPMENT EFC						
GE# 7459	906 786-7242	200 NORTH 12TH STREET	ESCANABA	MI	49829	
KEENE SMALL ENGINE SALES & SERVICE	989 8713458	4717 ARBELA ROAD	MILLINGTON	MI	48746	
DO IT BEST #6281		5190 W MICHIGAN AVE	KALAMAZOO	MI	49006	
CENDANT EQUIPMENT LEASING CO. LLC	989 839-7580	3003 E. COMMERCIAL DR	MIDLAND	MI	48642	

FOSTER'S ACE #12057N	906	293-3275	2011 S NEWBERRY AVE	NEWBERRY	MI	49868
MCLEAN'S HARDWARE	231	258-9136	109 E OAK STREET	KALKASKA	MI	49646
WARNER SPLY	269	657-3605	136 EAST MICHIGAN AVE	PAW PAW	MI	49079
FAMILY FARM & HOME GRAND RPDS DIB 3			4325 PLAINFIELD AVENUE NE	GRAND RAPIDS	MI	49525
ALMA TRUE VALUE HARDWARE	989	463-1415	102 W SUPERIOR ST	ALMA	MI	48801
GILBERTS	989	723-2330	113 W MAIN ST	OWOSSO	MI	48867
STARR LAWN & GARDEN, INC.	269	792-4123	3929 S. DIVISION AVE	WAYLAND	MI	49348
OAKLAND LAWN & GARDEN EQUIPT	248	673-5296	2934 FREMBES RD	WATERFORD	MI	48329
NORTH CENTER FARM SUPPLY	810	784-5331	75075 NORTH AVE	ARMADA	MI	48005
FORTON'S MOWER SHOP	586	775-7572	21707 HARPER AVE	SAINT CLAIR SHORES	MI	48080
THESIER EQUIPMENT CO.	248	437-2091	28342 PONTIAC TRL	SOUTH LYON	MI	48178
COUNTRY CORNER FARM & HOME SUPPLY	810	798-8255	515 S MAIN ST	ALMONT	MI	48003
ZIMMERS SALES & SERVICE	810	329-7136	6667 SAINT CLAIR HWY	EAST CHINA	MI	48054
WEINGARTZ SUPPLY INC.	616	696-2913	11875 NORTHLAND DR	CEDAR SPRINGS	MI	49319
ROBBINS ROAD HARDWARE	616	842-1321	948 ROBBINS RD	GRAND HAVEN	MI	49417
JACK'S LAWN SERVICE, INC	734	243-3382	15550 GARDEN STONE DR	MONROE	MI	48161
STRICKERS OUTDOOR POWER EQUIP LL	231	943-3709	707 W BLUE STAR DR	TRAVERSE CITY	MI	49685
SCHAVE'S SMALL ENGINE REPAIR	989	428-4242	4238 MAIN ST	PORT HOPE	MI	48468
UNITED RENTALS	616	364-7031	2122 TURNER AVE NW	GRAND RAPIDS	MI	49544
REED CITY HARDWARE	231	836-5302	114 W UPTON AVE	REED CITY	MI	49677
WM F SELL & SONS	734	692-5100	25151 ALLEN RD	TRENTON	MI	48183
KUBOTA OF WEST MICHIGAN GEORGE HOFACKER EQUIPMENT	616	877-0800	430 100TH ST.	BYRON CENTER	MI	49315
BATES TRACTOR & EQUIPMENT, INC.	616	784-2998	3633 4 MI. RP NW	GRAND RAPIDS	MI	49544
BOULLION SALES	517	279-9179	461 E FENN RD	COLDWATER	MI	49036
FERGUSON'S LAWN EQUIPMENT	734	426-8527	8530 N TERRITORIAL RD	DEXTER	MI	48130
BILL'S SPORT SHOP HOFFMAN'S POWER EQUIPMENT	231	946-2440	955 S. AIRPORT RD	TRAVERSE CITY	MI	49686
R&B LAWNMOWERS INC	616	846-9055	401 W SAVIDGE ST	SPRING LAKE	MI	49456
BAD BOY EQUIPMENT	989	792-8676	3139 ENTERPRISE DR	SAGINAW	MI	48603
OAKLAND LAWN & GARDEN	313	341-6100	2950 PURITAN ST	DETROIT	MI	48238
JOHN HOKSEMA INC	517	529-4291	10326 S MERIDIAN RD	CLARKLAKE	MI	49234
Burdick Street Equipment PS & T POWER EQUIPMENT & SUPPLY	248	673-5296	2934 FREMBES RD	WATERFORD	MI	48329
D & D SMALL ENGINE Genes Power Equipment Sales	616	396-8132	11483 E LAKEMOOD BLVD	HOLLAND	MI	49424
LLOYD'S REPAIR SERVICE	248	969-2800	43 E BURDICK ST	OXFORD	MI	48371
MUNN TRACTOR & LAWN, INC.	616	846-0884	17276 ROBBINS RD	GRAND HAVEN	MI	49417
	734	587-8825	9551 OSTRANDER RD	MAYBEE	MI	48159
	989	465-1521	981 E RAILWAY ST	COLEMAN	MI	48618
	517	451-8430	7750 RIDGE HWY	BRITTON	MI	49229
	248	373-5000	3700 LAPEER RD	AUBURN HILLS	MI	48326

BEE'S SPORTS, FARM & AUTO INC	989 224-3201	2138 S US HIGHWAY 27	SAINT JOHNS	MI	48879
LAPEER SPORT CENTER	810 245-0400	895 S MAIN	LAPEER	MI	48446
FLUSHING LAWN & TRACTOR LLC	810 639-2002	9112 W. MT MORRIS RD	FLUSHING	MI	48433
VERN'S REPAIR & SPORT, LLC	517 566-8353	11994 W. GRAND	LAKE ODESSA	MI	48849
LLOYD MILLER & SONS INC	989 748-4049	3695 E M 21	CORUNNA	MI	48817
BERNARD BUILDING CENTER, INC	989 728-2211	395 SOUTH WASHINGTON	HALE	MI	48739
LECKLER'S INC	734 242-2344	13001 TELEGRAPH RD	LA SALLE	MI	48145
OXFORD HARDWARE	248 628-9335	190 S WASHINGTON	OXFORD	MI	48371
MENOMINEE INDUSTRIAL SUPPLY, LLC	906 863-6332	1112 26TH AVE	MENOMINEE	MI	49858
HUNTOON LUMBER DO IT CENTER	989 635-7548	2424 VAN DYKE	MARLETTE	MI	48453
VIP OUTDOOR POWER LLC	616 842-0229	17169 HAYES ST STE B	GRAND HAVEN	MI	49417
WEINGARTZ SUPPLY COMPANY INC	734 239-8200	5436 JACKSON RD	ANN ARBOR	MI	48103
PAW PAW RENTALS	209 657-7762	707 W MICHIGAN AVE	PAW PAW	MI	49079
MIKE'S POWER EQUIPMENT LLC		2153 S US 27	SAINT JOHNS	MI	48879
DABO INC DBA MIDWEST POWER	517 349-6271	2446 JOLLY RD	OKEMOS	MI	48864
BERGMAN POWER EQUIPMENT	616 453-9581	4073 REMEMBRANCE ROAD NW	GRAND RAPIDS	MI	49534
1RATIOT TRUE VALUE HARDWARE	313 921-7896	6844 GRATIOT AVE	DETROIT	MI	48207
ALL SEASONS LANDSCAPING	734 697-1377	8124 BELLEVILLE RD	BELLEVILLE	MI	48111
SANFORD HARDWARE	989 687-5319	346 W SAGINAW ROAD	SANFORD	MI	48657
HOMETOWNE RENTALS	906 774-0355	213 S CARPENTER AVE	KINGSFORD	MI	49802
HOEKSTRA TRUCK EQUIPMENT	616 241-6664	260 36TH STREET	GRAND RAPIDS	MI	49548
GREEN ACE HARDWARE, INC	989 345-0020	2106 S. M-76	WEST BRANCH	MI	48661
SEBEWAING ACE HARDWARE	989 883-2740	8840 UNIONVILLE RD	SEBEWAING	MI	48759
DUNDEE AUTO PARTS	734 529-2800	180 MAIN	DUNDEE	MI	48131
FORMULA K FAMILY FUN PARKS, INC DBA	269 668-4070	54358 W MAIN ST	MATTAWAN	MI	49071
MEGA POWER SPORTS LLC	989 732-2500	2484 S OTSEGO AVE	GAYLORD	MI	49735
KELLOGG SMALL ENGINE REPAIR LLC	269 781-1102	1002 E MICHIGAN AVE	MARSHALL	MI	49068
MACOMB ACE HARDWARE	586 786-9040	51254 ROMEO PLANK RD	MACOMB	MI	48042
ACE HARDWARE OF SANDUSKY	810 648-2330	85 SOUTH ELK ST	SANDUSKY	MI	48471
HOLST ENTERPRISES INC	616 392-8539	62 WAVERLY RD	HOLLAND	MI	49423
MILLER'S SALES AND SERVICE	269 432-2008	27693 MARVIN RD	CENTREVILLE	MI	49032
TAYLOR POWER & SUPPLY LLC	231 627-4340	590 E VFW ROAD	CHEBOYGAN	MI	49721
ACO HARDWARE	248 471-0100	23333 COMMERCE DRIVE	FARMINGTON HILLS	MI	48335
FOREST GROVE LAWN AND RENTAL	616 896-8344	3188 32ND AVE	HUDSONVILLE	MI	49426
WALTERS EQUIPMENT LLC	616 878-7131	8433 CENTRE INDUSTRIAL DR	BYRON CENTER	MI	49315
GRULERS FARM SUPPLY		125 FULTON ST	PETOSKEY	MI	49770

SELF SERVE			1621 S. WHEELER	SAGINAW	MI	48602
BIG ACRE STORE			102 MAIN STREET	DAVISON	MI	48423
LEE WILLOW CORPORATION	989	662-6684	5024 SOUTH GARFIELD RD	AUBURN	MI	48611
HUNT'S ACE HARDWARE	248	474-8700	33567 7 MILE RD	LIVONIA	MI	48152
SARANAC HARDWARE	616	642-9227	89 N BRIDGE ST	SARANAC	MI	48881
ACE HARDWARE & SPORTS	989	832-8829	419 EAST MAIN STREET	MIDLAND	MI	48640
BILL'S REPAIR & SHARPENING	989	725-2533	985 W. BENNINGTON RD	OWOSSO	MI	48867
BORNTRAGER SMALL ENGINE	517	726-0665	3935 N BRADLEY RD	CHARLOTTE	MI	48813
BRIGG'S TRUE VALUE						
HARDWARE	231	845-7318	5840 W US 10	LUDINGTON	MI	49431
BUCKLEY HARDWARE INC	231	269-3440	379 WEST WEXFORD AVE	BUCKLEY	MI	49620
BURNIP'S EQUIPMENT						
COMPANY	616	896-9190	3260 142ND AVE	DORR	MI	49323
BUSH HARDWARE	989	291-3411	231 SOUTH MAIN	SHERIDAN	MI	48884
C & R TRUE VALUE INC	989	697-3095	891 S. HURON	LINWOOD	MI	48634
CASS CITY HARDWARE	989	872-2188	6092 E. CASS CITY RD	CASS CITY	MI	48726
COUNTRYSIDE SALES & SERVICE	989	637-4795	6201 STAGE RD	IONIA	MI	48846
DEAN'S FARM SUPPLY	517	437-3410	126 STATE STREET	HILLSDALE	MI	49242
DEXTERS INC						
			3804 S ADRIAN HWY	ADRIAN	MI	49221
ELLIOTT SAW WORKS	248	398-0440	22000 WOODWARD AVE	FERNDALE	MI	48220
ELMER'S SAW SALES	989	734-4666	6075 W HEYTHALER HWY	ROGERS CITY	MI	49779
GAMBLES ALPENA HARDWARE,						
INC	989	356-6356	2534 US 23 SO	ALPENA	MI	49707
GINOP SALES, INC	231	548-2272	11274 M68 WEST	ALANSON	MI	49706
JL'S SALES & SERVICE	810	672-8190	2676 DOWNINGTON ROAD	SNOVER	MI	48472
JOHNSTON ELEVATOR	989	386-7271	307 NORTH MC EWAN	CLARE	MI	48617
LUTKE HYDRAULICS	231	824-9505	606 RW HARRIS DR	MANTON	MI	49663
MERIDIAN HARDWARE &						
SPORT	989	687-5342	3102 NORTH M-30	SANFORD	MI	48657
P.J.'S MINI MOTORS	989	275-9018	249 E. FEDERAL HWY	ROSCOMMON	MI	48653
REMUS REPAIR	989	967-3624	2509 9 MILE	REMUS	MI	49340
ROSY BROS. INC.	810	796-3770	5727 DRYDEN RD	DRYDEN	MI	48428
SHLEBY LOGGING SUPPLIES, INC	231	861-5439	91 BEVIER ST.	SHELBY	MI	49455
SLOAT AUTO & FARM SUPPLY						
INC	231	839-7211	1343 S. LAKESHORE DR	LAKE CITY	MI	49651
SOUTH EVART SALES & SERVICE	231	734-5811	1811 70TH AVENUE	EVART	MI	49631
THE POWER SHOP	231	924-3540	7441 W. 48TH ST	FREMONT	MI	49412
VASSAR AUTO SUPPLY	989	823-8587	1194 W. SAGINAW	VASSAR	MI	48768
WATSON'S MARINA	906	586-9731	17225 MAIN STREET	CURTIS	MI	49820
WOLVERINE SMALL ENG.						
REP. INC	231	525-8004	12297 BILDER RD	WOLVERINE	MI	49799
WOODY'S SMALL ENG. REPAIR	616	772-2130	252 W. WASHINGTON	ZEELAND	MI	49464
BERGERON MARINE	906	474-9202	7794 HWY 2	RAPID RIVER	MI	49878
NORDIC TRADING POST, INC.	906	542-6691	6766 STATE HWY MI 69	FELCH	MI	49831
ROVELSKY & COMPANY	906	932-1830	215 W MCCLOUD AVE	IRONWOOD	MI	49938
STIHL SAW SALES	906	497-5542	3904 POTTER DRIVE	POWERS	MI	49874

US-2 RENTAL	906	875-7368	1497 US-2 W	CRYSTAL FALLS	MI	49920
LAMBERTVILLE DO IT BEST	734	856-3703	8100 SECOR RD	LAMBERTVILLE	MI	48144
BLISSFIELD OUTDOOR POWER	517	682-1886	203 S. LANE ST	BLISSFIELD	MI	49228
CARROLL STREAM MOTOR COMPANY	248	628-4638	425 W. DAVIDSON LAKE RD	OXFORD	MI	48371
FAMILY FARM & HOME			716 CHICAGO DRIVE SUITE 500	HOLLAND	MI	49423
BARNES TRUE VALUE			132 W MAIN ST	CARSON CITY	MI	48811
TRUE VALUE OF GREENVILLE	616	232-2800	701 S. GREENVILLE W. DR STE 7	GREENVILLE	MI	48838
ACE HARDWARE OF ROCKFORD	616	866-9155	643 NORTHLAND DRIVE	ROCKFORD	MI	49341
SUMMIT POINTE SALES LLC	816	262-1217	4668 DIVISION AVE S	WAYLAND	MI	49348
APCO DO IT BEST			5511 ENTERPRISE DRIVE	LANSING	MI	48911
BETSIIE VALLEY SALES & SERVICE, INC.	231	882-7273	6934 RIVER ST	BENZONIA	MI	49616
HAVIT SUPPLY	616	532-2923	2830 LOCKE AVE SW	GRANDVILLE	MI	49418
LUMBERJACK BUILDING CENTERS INC	810	794-4984	3470 PTE TREMBLE RD	ALGONAC	MI	48001
WARNER SUPPLY DIB	269	628-6400	33310 M-43 HWY	PAW PAW	MI	49079
EWEN DO IT BEST	906	988-2385	500 PINE ST	EWEN	MI	49925
PAIDL'S DO IT CENTER	906	753-1087	N8077 US HIGHWAY 41	STEPHENSON	MI	49887
LAKESIDE MOTOR SPORTS, INC.	231	972-4146	4566 N. GREENVILLE RD	GREENVILLE	MI	48838
ALLEGAN TRUE VALUE			1527 LINCOLN RD	ALLEGAN	MI	49010
HARDWARE	269	673-3255	415 EAST LAKE STREET	SOUTH LYON	MI	48178
PTV ENTERPRISES	248	437-1751				
DANTECH OUTDOOR POWER EQUIPMENT	586	716-2122	10320 DIXIE HWY	FAIR HAVEN	MI	48023
AMERICAN ENERGY VENTURES INC DBA	269	484-9273	95 E MICHIGAN AVE	GALESBURG	MI	49053
FORSLUND BUILDING SUPPLY	906	932-2311	E5108 JACKSON ROAD	IRONWOOD	MI	49938
WW FARIBAIRN	231	548-2244	7537 BURR AVE	ALANSON	MI	49706
ATLANTA HARDWARE	989	785-3351	12374 STATE ST	ATLANTA	MI	49709
KERR'S EQUIPMENT	734	231-1400	25024 RESEARCH WAY	WOODHAVEN	MI	48183
KIRKS SUPPLY	989	672-9959	3995 FAIRGROVE RD	FAIRGROVE	MI	48733
SHELL AUTO	989	733-8031	20468 STATE STREET	ONAWAY	MI	49765
JONS REPAIR SHOP	231	924-9007	5876 BINGHAM AVE	NEWAYGO	MI	49337
STANTON HARDWARE	989	283-1131	102 N MILL ST	STANTON	MI	48888
C&C REPAIR	517	962-5292	5028 PAGE AVE	JACKSON	MI	49201
STEVENSVILLE ACE	269	429-7133	1545 WEST JOHN BEERS	STEVENSVILLE	MI	49127
BORRE HARDWARE ACE	269	429-1504	2360 NILES RD	SAINT JOSEPH	MI	49085
MANISTEE ACE	231	723-9145	1425 US 31 SOUTH	MANISTEE	MI	49660
MARTINS HOME CENTER	517	423-2065	145 W. CHICAGO BLVD	TECUMSEH	MI	49286
WHISKEY RIVER DIB	906	478-3821	19030 S. MACKINAC TRAIL	RUDYARD	MI	49780
MICHIGAN EQUIPMENT RENTAL	248	625-1515	4906 WHITE LAKE ROAD	CLARKSTON	MI	48346
HUNTING LAWN & SNOW	517	645-7777	550 EAST MAIN ST	POTTERVILLE	MI	48876
POWER-ON OUTDOOR N MORE LLC	269	789-0776	17441 L DRIVE NORTH	MARSHALL	MI	49068
LUZERNE HARDWARE	989	826-8050	2244 DEETER RD	LUZERNE	MI	48636

HYDE SERVICES	231	347-4725	1688 MCDUGAL RD	PETOSKEY	MI	49770
HILLCREST FARM SUPPLY	906	586-6383	1652 COUNTY ROAD 413 S	MCMILLAN	MI	49853
MICHIANA TOOL RENTAL INC	269	687-1700	3003 S. 11TH ST	NILES	MI	49120
VASSAR BUILDING CETNER	989	823-8513	1013 W. SAGINAW RD	VASSAR	MI	48768
GREENVILLE TRUE VALUE	616	232-2800	701 S GREENVILLE RD	GREENVILLE	MI	48838
BELLEVUE HARDWARE	517	719-0861	220 S. MAIN ST	BELLEVUE	MI	49021
HOFFERBERT SALES INC	989	862-5300	200 N MAPLE ST	BANNISTER	MI	48807
HOWARD'S WATER PUMPS & SERVICES INC	906	786-2271	10431 N-15 LANE	GLADSTONE	MI	49837
SOMSEL LUMBER COMPANY	231	362-3103	14261 9 MILE RD	KALEVA	MI	49645
FRANKENMUTH TRUE VALUE	989	652-0021	469 N. MAIN ST	VASSAR	MI	48768
WILLIS LAWN & GARDEN	734	483-7548	6394 WILLIS ROAD	YPSILANTI	MI	48197
MADIGAN'S ACE HARDWARE	906	387-2033	202 ELM AVE	MUNISING	MI	49862
SAXTON'S POWER EQUIPMENT	734	453-6250	587 W. ANN ARBOR	PLYMOUTH	MI	48170
AUSRA EQUIPMENT & SUPPLY CO., INC.	269	782-7178	30155 YAW ST	DOWAGIAC	MI	49047
GILBERTS DO IT BEST HARDWARE	517	669-1200	12900 S US HWY 27	DEWITT	MI	48820
DERONNE HARDWARE	586	779-5000	28700 HARPER	ST CLAIR SHORES	MI	48081
GREAT LAKE SNOW & ICE EQUIPMENT	989	584-1211	7123 S GARLOCK RD	CARSON CITY	MI	48811
HOLLYWOOD SMALL ENGINE LLC	269	556-1052	210 E. JOHN BEERS RD	SAINT JOSEPH	MI	49085
DOUGLAS POWERSPORTS SERVICE CENTER	989	891-1000	59 N TUSCOLA RD	BAY CITY	MI	48708
BEN'S SUPERCENTER	989	635-4069	6541 PLAZA DRIVE	MARLETTE	MI	48453
T. ESTERDAHL INVESTMENTS LLC	810	487-0676	424 W. MAIN ST	FLUSHING	MI	48433
S.S. EQUIPMENT REPAIR LLC	810	660-8552	3720 N. LAPEER RD	LAPEER	MI	48446
NORTHBANK HARDWARE	616	844-0243	17697 174TH ST	SPRING LAKE	MI	49456
SCHMITZER HARDWARE INC	989	624-9222	11944 CONQUEST ST	BIRCH RUN	MI	48415
ACE HARDWARE OF CLARKSTON	248	707-6509	6669 DIXIE HIGHWAY	CLARKSTON	MI	48346
HALES TRUE VALUE	269	782-3426	56216 M-51 SOUTH	DOWAGIAC	MI	49047
RED'S REPAIR	989	588-7052	7972 N WINN RD	FARWELL	MI	48622
B F K ENTERPRISE LLC	810	679-4494	4256 PECK RD	CROSWELL	MI	48422
MOE SALES & SERVICE INC	810	744-3520	G3228 KLEINPELL ST	BURTON	MI	48529
DOUG'S REPAIR LLC	734	847-7474	7332 LEWIS AVE	TEMPERANCE	MI	48182
SUNRISE SMALL ENGINE	989	747-5810	4374 F 41	OSCODA	MI	48750
STAN'S YARD & SPORT LLC	269	628-1111	13383 35TH ST	GOBLES	MI	49055
SLOAN'S SALES & SERVICE LLC	810	458-4299	1005 N BRIDGE ST	LINDEN	MI	48451
DARLING'S BELTLINE LLC	810	987-9555	3203 LAPEER RD	PORT HURON	MI	48060
DEISLER OUTDOOR POWER EQMT	989	720-5296	227 SLEESMAN DR	CORUNNA	MI	48817
ALL SEASON SERVICE & SALES LLC	989	479-0444	227 INDUSTRIAL DR	HARBOR BEACH	MI	48441
NATE'S LAWN SHOP	810	659-6446	4057 COMMERCE DR	FLUSHING	MI	48433
M & J SMALL ENGINE REP. LLC	517	238-5690	292 E SOUTHERN RD	COLDWATER	MI	49036

A&R POWER EQUIPMENT	989 345-3350	3218 W M 76	WEST BRANCH	MI	48661
BID'S SERVICE INC	586 759-3040	11276 E 10 MILE RD	WARREN	MI	48089
SUPERIOR INDUSTRIALS & S INC	517 784-0539	116 N STATE ST	JACKSON	MI	49201
HASTING ACE HARDWARE #120131	269 945-2003	200 S BOLTWOOD ST	HASTINGS	MI	49058
HAIG'S MOWER SERVICE INC	313 893-0909	20404 WOODWARD AVE	DETROIT	MI	48203
STRUBLE'S HARDWARE & SUPPLY	269 979-4700	4675 CAPITAL AVE SW	BATTLE CREEK	MI	49015
TONY'S MOWER SHOP INC	734 420-9083	40970 FIVE MILE RD	PLYMOUTH	MI	48170
THREE J'S SMALL ENGINE	248 437-0217	3900 7 MILE RD	SOUTH LYON	MI	48178
MR. SMALL ENGINE SALES	269 471-5868	9549 US 31 SOUTH	BERRIEN SPRINGS	MI	49103
M & E SERVICE	231 946-3348	6375 E TRAVERSE HWY	TRAVERSE CITY	MI	49684
UNIVERSITY LAWN EQUIPMENT	248 373-7220	945 UNIVERSITY DR	PONTIAC	MI	48342
CHICAGO DRIVE RENTALS	616 396-9575	11298 CHICAGO DR	HOLLAND	MI	49424
BOB'S ENGINE HOSPITAL INC	616 690-4061	314 ARLINGTON ST	MIDDLEVILLE	MI	49333
GEORGE'S LAWNMOWERS & S	313 937-2455	26118 PLYMOUTH ROAD	REDFORD	MI	48239
BOBS SERVICE SHOP LLC	248 628-2601	2537 W DRAHNER RD	OXFORD	MI	48371
TOM DEYOUNG'S ENGINE & MOWER	616 538-0046	3642 CLYDE PARK AVE SW	WYOMING	MI	49509
WHITE LAKE NURSERY INC	231 894-8574	1311 E COLBY ST	WHITEHALL	MI	49461
MIDSTATE SALES & SERVICE	989 224-2711	3251 W MI 21	SAINT JOHNS	MI	48879
ADVANCED ENGINE & MOWER	313 945-6656	4890 GREENFIELD RD	DEARBORN	MI	48126
WAYNE'S SHARP ALL INC	989 734-4053	2246 US HIGHWAY 23 S	ROGERS CITY	MI	49779
DON'S SMALL ENGINE REPAIR INC	734 451-5656	630 S MILL ST	PLYMOUTH	MI	48170
FRASER LAWN CENTER INC	586 293-0310	31819 UTICA RD	FRASER	MI	48026
FREMONT OUTDOOR POWER INC	231 924-6009	5554 S WARNER AVE	FREMONT	MI	49412
MEL'S SMALL ENGINE REPAIR	517 676-4107	5900 NICHOLS RD	MASON	MI	48854
ANGELO'S SMALL ENGINE	269 463-8130	7174 RED ARROW HWY	COLOMA	MI	49038
LANGLEYS SMALL ENGINES	989 435-2572	3794 BARD RD	BEAVERTON	MI	48612
THOMPSON'S RENTAL RESALE REP	810 266-4969	11973 NEW LOTHROP RD	BYRON	MI	48418
LANSING C&K SMALL ENGINE REP	517 393-4332	5920 S PENNSYLVANIA AVE	LANSING	MI	48911
HOWELL LAWNMOWER & RADIATOR	517 546-2790	2435 E GRAND RIVER AVE	HOWELL	MI	48843
APPLE POWER SPORTS	616 350-1131	4550 17 MILE RD	KENT CITY	MI	49330
BERGMAN POWER EQUIPMENT LLC	616 453-9581	4073 REMEMBRANCE RD NW	GRAND RAPIDS	MI	49534
CANTON LAWN & SNOW	734 416-8050	7775 N SHELDON RD	CANTON	MI	48187
DON'S SMALL ENGINE REPAIR	517 567-8941	4000 BUCKEYE RD	CAMDEN	MI	49232
GALLANT & SON	517 263-1998	801 N MAIN ST	ADRIAN	MI	49221
JERRY'S LITTLE ENGINE REPAIR	616 886-6611	3940 GORDON ST	HUDSONVILLE	MI	49426
MASTER SERVICE CENTER	616 647-0654	5210 WEST RIVER DR NE STE A	COMSTOCK PARK	MI	49321
MONDRY HARDWARE	313 894-3260	6659 MICHIGAN AVE	DETROIT	MI	48210

QUALITY SMALL ENGINE REPAIR	616	554-0040	1562 68TH ST SE	GRAND RAPIDS	MI	49508	
REED'S EQUIPMENT LLC	517	567-4415	10815 S PITTSFORD RD	PITTSFORD	MI	49271	
TOOL MEDIC	810	687-6691	11395 N SAGINAW RD STE 6	CLIO	MI	48420	
WAYLAND OUTDOOR POWER	269	792-9377	200 COMMERCE ST	WAYLAND	MI	49348	
WOLF LAKE REPAIR	231	745-3071	764 N MI 37	BALDWIN	MI	49304	
SPS REPAIR	989	286-6374	5984 STATE STREET	KINGSTON	MI	48741	
BRADLEY ACE HARDWARE	616	538-5170	31-44TH STREET SW	WYOMING	MI	49548	
NORTHERN INDUSTRIES	989	539-1990	10933 NORTH ATHEY AVE	HARRISON	MI	48625	
MAST'S ENGINE SERVICE	517	542-0158	11821 ANDERSON RD	LITCHFIELD	MI	49252	
COMMERCE ACE HARDWARE	248	360-0400	3050 UNION LAKE RD	COMMERCE TOWNSHIP	MI	48382	
BUDD'S ALL TRACTOR LLC	517	750-4550	6655 W. MICHIGAN AVE	JACKSON	MI	49201	
MY TOWN ACE	616	359-9300	1614 142ND AVE	DORR	MI	49323	
CI'S ACE HARDWARE	616	754-8990	306 MAPLEWOOD ST	GREENVILLE	MI	48838	
VILLWOCK'S LAWN & GARDEN	269	815-5415	8008 M139	BERRIEN SPRINGS	MI	49103	
OCEANA IRRIGATION SYSTEMS							
INC	231	873-5437	3338 W ABBEY RD	HART	MI	49420	
HDR SMALL ENGINE REPAIR	231	715-1349	905 HASTINGS ST	TRAVERSE CITY	MI	49686	
LOZON TRUE VALUE							
HARDWARE	313	841-2940	10563 WEST JEFFERSON	RIVER ROUGE	MI	48218	
GRAYLING POWER EQUIPMENT	989	348-9621	PO BOX 417	GRAYLING	MI	49738	
MCMOWER PARTS & MORE	586	899-3694	33830 GROESBECK HIGHWAY	CLINTON TOWNSHIP	MI	48035	
GREAT LAKES ACE	517	787-1570	1711 SPRING ARBOR RD	JACKSON	MI	49203	
NORTHSHORE HARDWARE	231	744-1280	605 WHITEHALL RD	NORTH MUSKEGON	MI	49445	
SPRATTS TRADING POST INC.	517	437-3773	3000 STATE RD	HILLSDALE	MI	49242	
GRASS DIRT SNOW	231	584-2868	5868 ALBA HWY	ALBA	MI	49611	
COUNTYLINE EQUIPMENT & TRAILERS	989	401-6344	22686 GRATIOT RD	MERRILL	MI	48637	
COUNTRY VILLAGE ACE	906	485-1870	1150 COUNTRY LANE	ISHPEMING	MI	49849	
T&J RICHARDSON, LLC	517	423-6088	3421 RUSSELL RD	TECUMSEH	MI	49286	
AJ RENTALS AND EQUIPMENT	989	846-4588	4433 S HURON RD	STANDISH	MI	48658	
KENSINGTON MOTORSPORTS, INC.	248	446-0000	56605 PONTIAC TRAIL	NEW HUDSON	MI	48165	
CAMPIONI'S TRUE VALUE	906	828-2404	104 N STEPHENSON AVE	IRON MOUNTAIN	MI	49801	
DICKINSON TRUE VALUE	269	561-4321	111 E MAIN ST	FENNVILLE	MI	49408	
REPAIRCLINIC, LLC	800	269-2609	48600 MICHIGAN AVE	CANTON	MI	48188	
WEINGARTZ SUPPLY CO., INC	586	731-7240	46061 VAN DYKE AVE	UTICA	MI	48317	
SELL'S EQUIPMENT	734	639-1230	2708 NORTH TELEGRAPH RD	MONROE	MI	48162	
ALPHA GROUP RETAIL LLC	616	754-8990	306 MAPLEWOOD STREET	GREENVILLE	MI	48838	
BANSKI SERVICES	989	732-1888	2307 S. OTSEGO AVE.	GAYLORD	MI	49735	
BEN'S SUPERCENTER INC.	810	346-2835	4436 WEST MAIN STREET	BROWN CITY	MI	48416	
ROGER'S OSCODA ENTERPRISES							
INC.	989	569-6304	5112 N US 23	OSCODA	MI	48750	
LEWISTON ACE HARDWARE	989	786-4910	4910 SALLING AVE	LEWISTON	MI	49756	
ACE HARDWARE OF CLARE	989	386-4000	10316 S. CLARE AVE.	CLARE	MI	48617	
COLOMA TRUE VALUE	269	468-3462	280 N. PAW PAW STREET	COLOMA	MI	49038	
JCL SNOWPLOW DEALER, INC	586	716-0116	10131 RADIANCE DR	FAIR HAVEN	MI	48023	

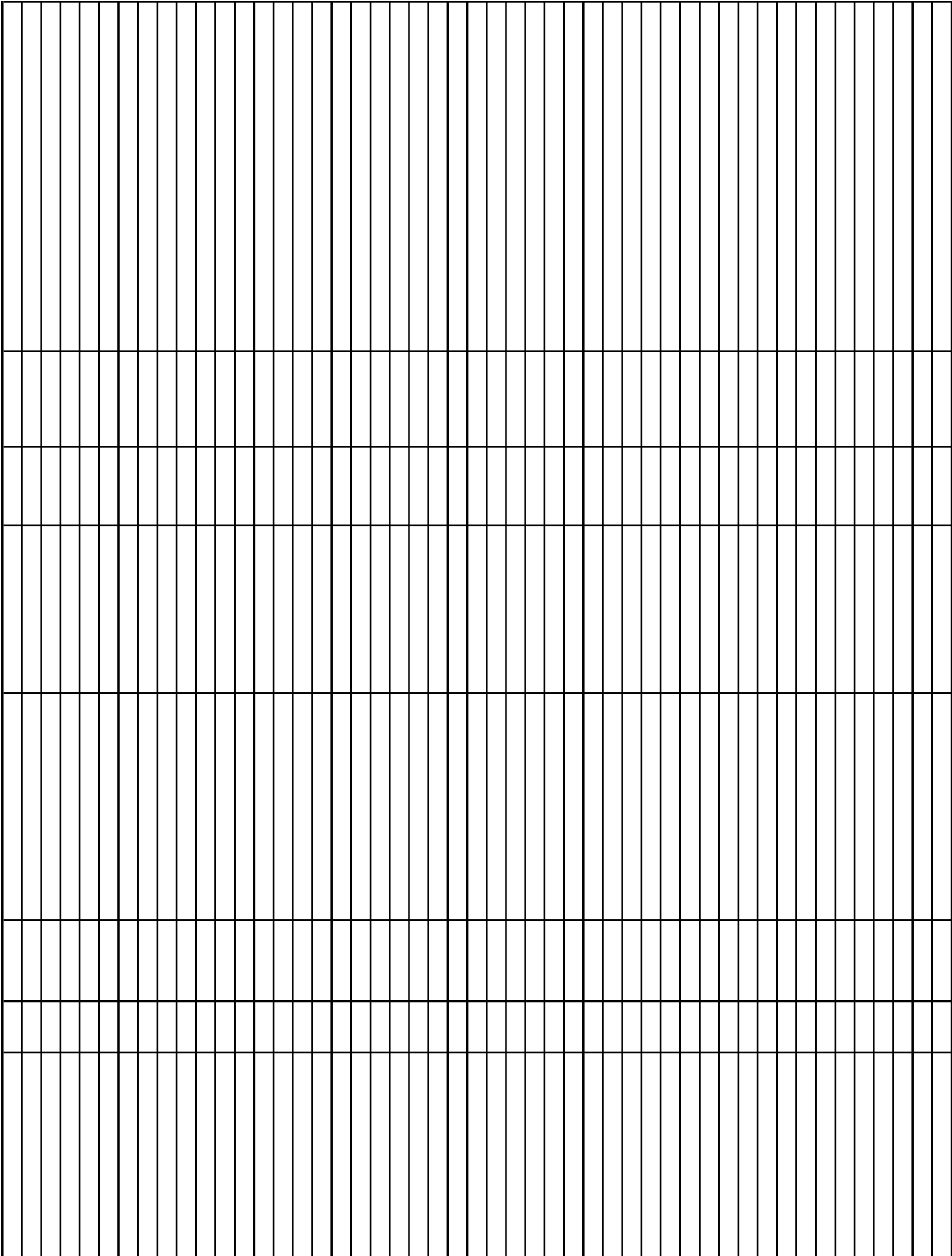

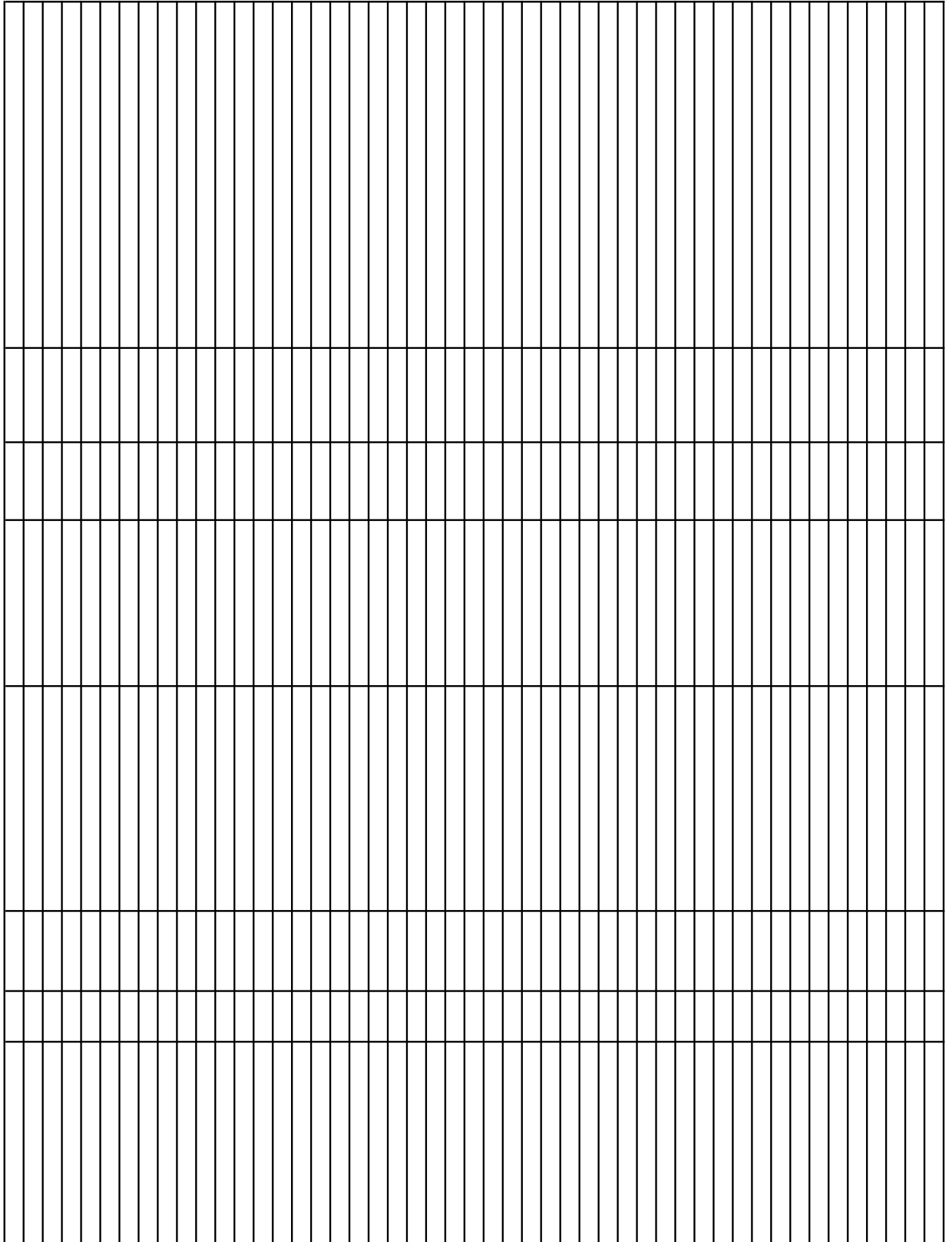



Association of Educational
PURCHASING AGENCIES

Part E – Signature Forms

AEPA IFB 020-E

Lawn & Groundskeeping Equipment, Supplies & Services

Instructions

Contained herein are forms that require a signature from an authorized person at your company. All items found within this document are **mandatory**. Failure to sign the required areas, sections, or signature lines will allow AEPA to consider your company's proposal as **non-responsive**.

To submit the required signed forms, follow these steps:

1. Read the documents in their entirety.
2. Complete all forms and sign when required.
3. Once signed, place notary stamp in the delegated area on the Bid Affidavit.
4. Return the forms and pages in their correct order and scan one (1) single PDF format titled "Part E - Signature Forms - Name of Bidding Company" (i.e. one PDF document for all signature forms).
5. Submit Part E, along with other required documents in Public Purchase.

AEPA does not allow electronic signatures.

*Note, a bid checklist has been provided to review with your submission.

The following sections will need to be completed prior to submission as one (1), single PDF titled "Part E - Signature Forms - Name of Bidding Company".

Uniform Guidance "EDGAR" Certification Form - **signature required*

Bid Affidavit - **signature required*

Acceptance of Bid & Contract Award - **signature required*

Uniform Guidance "EDGAR" Certification Form

2 CFR Part 200

When a purchasing agency seeks to procure goods and services using funds under a federal grant or contract, specific federal laws, regulations, and requirements may apply in addition to those under state law. This includes, but is not limited to, the procurement standards of the Uniform Administrative Requirements, Cost Principles and Audit Requirements for Federal Awards, 2 CFR 200, referred to as the "Uniform Guidance" or new "EDGAR". All bidders submitting proposals must complete this EDGAR Certification form regarding the bidder's willingness and ability to comply with certain requirements, which may be applicable to specific agency purchases using federal grant funds.

For each of the items below, the Bidder will certify its agreement and ability to comply, where applicable, by having the bidder's authorized representative check, initial the applicable boxes, and sign the acknowledgement at the end of this form. If a bidder fails to complete any item of this form, AEPA will consider and may list the response, as the bidders is unable to comply. A "No" response to any of the items below may influence the ability of a purchasing agency to purchase from the bidder using federal funds.

1. Violation of Contract Terms and Conditions

Provisions regarding bidder default are included in AEPA's terms and conditions. Any contract award will be subject to such terms and conditions, as well as any additional terms and conditions in any purchase order, ancillary agency contract, or construction contract agreed upon by the bidder and the purchasing agency, which must be consistent with and protect the purchasing agency at least to the same extent as AEPA's terms and conditions. The remedies under the contract are in addition to any other remedies that may be available under law or in equity.

2. Termination for Cause of Convenience

For a participating agency purchase or contract in excess of \$10,000 made using federal funds, you agree that the following term and condition shall apply:

The participating agency may terminate or cancel any purchase order under this contract at any time, with or without cause, by providing seven (7) business days in advance written notice to the bidder. If this agreement is terminated in accordance with this paragraph, the participating agency shall only be required to pay bidder for goods and services delivered to the participating agency prior to the termination and not otherwise returned in accordance with the bidder's return policy. If the participating agency has paid the bidder for goods and services provided as the date of termination, bidder shall immediately refund such payment(s).

If an alternate provision for termination of a participating agency's purchase for cause and convenience, including the manner by which it will be effected and the basis for settlement, is in the participating agency's purchase order, ancillary agreement or construction contract agreed to by the bidder, the participating agency's provision shall control.

3. Equal Employment Opportunity

Except as otherwise provided under 41 CFR Part 60, all participating agency purchases or contract that meet the definition of "federally assisted construction contract" in 41 CFR Part 60-1.3 shall be deemed to include the equal opportunity clause provided under 41 CFR 60-1.4(b), in accordance with Executive Order 11246, "Equal Employment Opportunity" (30 FR 12319, 12935, 3 CFR Part, 1964-1965 Comp., p. 339), as amended by Executive Order 11375, "Amending Executive Order 11246 Relating to Equal Employment Opportunity," and implementing regulations at 41 CFR Part 60, "Office of Federal Contract Compliance Programs, Equal Employment Opportunity, Department of Labor."

The equal opportunity clause provided under 41 CFR 60-1.4(b) is hereby incorporated by reference. Bidder agrees that such provision applies to any participating agency purchase or contract that meets the definition of "federally assisted construction contract" in 41 CFR Part 60-1.3 and bidder agrees that it shall comply with such provision.

4. Davis Bacon Act

When required by Federal program legislation, bidder agrees that, for all participating agency contracts for the construction, alteration, or repair (including painting and decorating) of public buildings or public works, in excess of \$2,000, bidder shall comply with the Davis-Bacon Act (40 U.S.C. 3141-3144, and 3146-3148) as supplemented by Department of Labor regulations (29 CFR Part 5, "Labor Standards Provisions Applicable to Contracts Covering Federally Financed and Assisted Construction"). In accordance with the statute, bidder is required to pay wages to laborers and mechanics at a rate not less than the prevailing wages specific in a wage determinate made by the Secretary of Labor. In addition, bidder shall pay wages not less than once a week.

Current prevailing wage determinations issued by the Department of Labor are available at www.wdol.gov. Bidder agrees that, for any purchase to which this requirement applies, the award of the purchase to the bidder is conditioned upon bidder's acceptance of wage determination.

Bidder further agrees that is shall also comply with the Copeland "Anti-Kickback" Act (40 U.S.C. 3145), as supplemented by Department of Labor regulations (29 CFR Part 3, "Contractors and Subcontractors on Public Building or Public Work Financed in Whole or in Part by Loans or Grants from the United States"). The Act provides that each construction completion, or repair of public work, to give up any part of the compensation to which he is otherwise entitled under his contract of employment, shall be defined under this titled or imprisoned not more than five (5) years, or both.

5. Contract Work Hours and Safety Standards Act

Where applicable, for all participating agency purchases in excess of \$100,000 that involve the employment of mechanics or laborers, bidder agrees to comply with 40 U.S.C. 3702 and 3704, as supplemented by Department of Labor regulations (29 CFR Part 5). Under 40 U.S.C. 3702 of the Act, bidder is required to compute the wages of every mechanic and laborer on the basis of a standard work week of 40 hours. Work in excess of the standard work week is permissible provided that the worker is compensated at a rate of not less than one and a half times the basic rate of pay for all hours worked in excess of 40 hours in the work week. The requirements of the 40 U.S.C. 3704 are applicable to construction work and provide that no laborer or mechanic must be required to work in surroundings or under working conditions that are unsanitary, hazardous or dangerous. These requirements do not apply to the purchase of supplies, materials or articles ordinarily available on the open market, or contracts for transportation or transmission of intelligence.

6. Right to Inventions Made Under a Contract or Agreement

If the participating agency's federal award meets the definition of "funding agreement" under 37 CFR 401.2(a) and the recipient or sub recipient wishes to enter into a contract with a small business firm or nonprofit organization regarding the substitution of parties, assignment or performance or experiments, developmental or research work under the "funding agreement," the recipient or sub recipient must comply with the requirements of 37 CFR Part 401, "Rights to Inventions Made by Nonprofit Organizations and Small Business Firms Under Government Grants, Contracts and Cooperative Agreements," and any implementing regulations issued by the awarding agency.

7. Clean Air Act and Federal Water Pollution Control Act

Clean Air Act (42 U.S.C. 7401-7671q.) and the Federal Water Pollution Control Act (33 U.S.C. 1251-1387), as amended, contracts and sub grants of amounts in excess of \$150,000 must contain a provision that requires the non-Federal award to agree to comply with all applicable standards, orders, or regulations issued pursuant to the Clean Air Act (42 U.S.C. 7401-7671q.) and the Federal Water Pollution Control Act, as amended (33 U.S.C. 1251-1387). Violations must be reported to the Federal awarding agency and the Regional Office of the Environmental Protection Agency (EPA). When required, bidder agrees to comply with all applicable standards, orders, or regulations issued pursuant to the Clean Air Act and the Federal Water Pollution Control Act.

8. Debarment and Suspension

Debarment and Suspension (Executive Orders 12549 and 12689), a contract award (see 2 CFR 180.222) must not be made to parties listed on the government-wide exclusions in the System for Award Management (SAM), in accordance with OMB guidelines at 2 CFR 180 that implement Executive Orders 12549 (3 CFR Part 1966 Comp. p. 189) and 12689 (3 CFR Part 1989 Comp. p. 235), "Debarment and Suspension." SAM exclusions contain the names of parties debarred, suspended, or otherwise excluded by agencies, as well as parties declared ineligible under statutory or regulatory authority other than Executive Order 12549. Bidder certifies that the bidder is not current listed and further agrees to immediately notify AEPA and all participating agencies with pending purchases or seeking to purchase from the bidder if bidder is later listed on the government-wide exclusions in SAM, or is debarred, suspended, or otherwise excluded by agencies or declared ineligible under statutory or regulatory authority other than Executive Order 12549.

9. Byrd Anti-Lobbying Amendment

Byrd Anti-Lobbying Amendment (31 U.S.C. 1352), bidders that apply or bid for an award exceeding \$100,000 must file the required certification. Each tier certifies to the tier above that it will not and has not used Federal appropriated funds to pay any person or organization for influencing or attempting to influence an officer or employee of any agency, a member of Congress, officer or employee of Congress, or an employee of a member of Congress in connection with obtaining any Federal contract, grant or any other award covered by 31 U.S.C. 1352. Each tier must also disclose any lobbying with non-Federal funds that take place in connection with obtaining any Federal award. Such disclosures are forwarded from tier to tier up to the non-Federal award.

10. Procurement of Recovered Materials

For participating agency purchases utilizing Federal funds, bidder agrees to comply with Section 6002 of the Solid Waste Disposal Act, as amended by the Resource Conservation and Recovery Act where applicable and provide such information and certifications as a participating agency may require to confirm estimates and otherwise comply. The requirements of Section 6002 include procuring only items designated in guidelines of the Environmental Protection Agency (EPA) at 40 CFR Part 247 that contain the highest percentage of recovered materials practicable, consistent with maintaining a satisfactory level of competition, where the purchase price of the item exceeds \$10,000 or the value of the quantity acquired during the preceding fiscal year exceeded \$10,000; procuring solid waste management services in a manner that maximizes energy and resource recover, and establishing an affirmative procurement program for procurement of recovered materials identified in the EPA guidelines.

11. Profit as a Separate Element of Price

For purchases using federal funds in excess of \$150,000, a participating agency may be required to negotiate profit as a separate element of the price. See 2 CFR 200.323(b). When required by a participating agency, bidder agrees to provide information and negotiate with the participating agency regarding profit as a separate element of the price for a particular purchase. However, bidder agrees that the total price, including profit, charged by the bidder to the participating agency shall not exceed the awarded pricing, including any applicable discount, under the bidders contract with AEPA.

12. General Compliance with Participating Agencies

In addition to the foregoing specific requirements, bidder agrees, in accepting any purchase order from a participating agency, it shall make a good faith effort to work with participating agency to provide such information and to satisfy requirements as may apply to a particular purchase or purchases including, but not limited to, applicable record keeping and record retention requirements as noted in the Federal Acquisition Regulation, FAR 4.703(a).

By initialing the table (1-12) and signing below, I certify that the information in this form is true, complete and accurate and that I am authorized by my business to make this certification and all consents and agreements contained herein.

Bidder Certification (By Item)	Bidder Certification: YES, I agree or NO, I do NOT agree	Initial
1. Violation of Contract Terms and Conditions	Yes	JD
2. Termination for Cause of Convenience	Yes	JD
3. Equal Employment Opportunity	Yes	JD
4. Davis-Bacon Act	Yes	JD
5. Contract Work Hours and Safety Standards Act	Yes	JD
6. Right to Inventions Made Under a Contract or Agreement	Yes	JD
7. Clean Air Act and Federal Water Pollution Control Act	Yes	JD
8. Debarment and Suspension	Yes	JD
9. Byrd Anti-Lobbying Amendment	Yes	JD
10. Procurement of Recovered Materials	No Yes	JD
11. Profit as a Separate Element of Price	Yes	JD
12. General Compliance with Participating Agencies	Yes	JD

Husquarna Professional Products Inc.

Name of Business

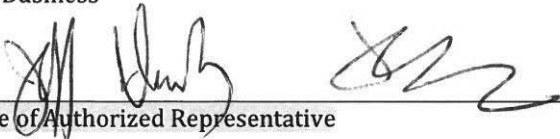

Signature of Authorized Representative

Jeff Dwosky Jill Jackson

Printed Name

9-12-19

Date

Bid Affidavit

Instructions: This form must be signed by the business's authorized representative and notarized below. If awarded, the Bidder is required to produce a copy of this document for each Member Agency with which it contracts.

1. The undersigned, is duly authorized to represent the persons, business and corporations joining and participating in the submission of the foregoing bid (such persons, business and corporations hereinafter being referred to as the bidder), being duly sworn, on his/her oath, states that to the best of his/her belief and knowledge no person, business or corporation, nor any person duly representing the same joining and participating in the submission of the foregoing bid, has directly or indirectly entered into any agreement or arrangement with any other bidders, or with any official of the **Member Agency**, or any employee thereof, or any person, business or corporation under contract with the **Member Agency** whereby the bidder, in order to induce the acceptance of the foregoing bid by the **Member Agency**, has paid, or is to pay to any other bidder, or to any of the aforementioned persons, anything of value whatever, and that the bidder has not, directly nor indirectly entered into any arrangement, or agreement, with any other bidder or bidders which tends to or does lessen or destroy free competition in the letting of the contract sought for by the foregoing bid.
2. This is to certify that the bidder, or any person on his/her behalf, has not agreed, connived, or colluded to produce a deceptive show of competition in the manner of the bidding, or award of the referenced contract.
3. This is to certify that neither I, nor to the best of my knowledge, information and belief, the bidder, nor any officer, director, partner, member or associate of the bidder, nor any of its employees directly involved in obtaining contracts with the **Member Agency**, or any subdivision of the state has been convicted of false pretenses, attempted false pretenses, or conspiracy to commit false pretenses, bribery, attempted bribery or conspiracy to bribe under the laws of any state or federal government for acts or omissions after January 1, 1985.
4. This is to certify that the bidder, or any person on his behalf has examined and understands the terms, conditions, scope of work and specifications, and other documents of this solicitation and that any and all exceptions have been noted in writing and have been included with the bid submittal.
5. This is to certify that if awarded a contract, the bidder will provide the equipment, commodities, and/or services to members and affiliate members of the Agency in accordance with the terms, conditions, scope of work and specifications and other documents of this solicitation in the following pages of this bid.
6. This is to certify that the bidder is authorized by the manufacturer(s) to sell all proposed products on a national basis.
7. This is to certify that we have completed, reviewed, approved and have included all information that is required of these bid forms.

<u>Jeff Dewosky</u> Authorized Representative (Please print or type)	<u>Jill Jacobson</u>	<u>9335 Harris Corners Pkwy, Suite 500</u> Mailing Address
<u>Vice President - Sales</u> Title (Please print or type)	<u>VP</u>	<u>Charlotte, NC, 28269</u> City, State, Zip
<u>[Signature]</u> Signature of Authorized Representative	<u>[Signature]</u>	<u>9-12-19</u> Date

Subscribed and sworn to before me this 12th day of September, 2019
Notary Public in and for County of Mecklenburg State of North Carolina
My commission expires on 9-29-2021 Signature [Signature]

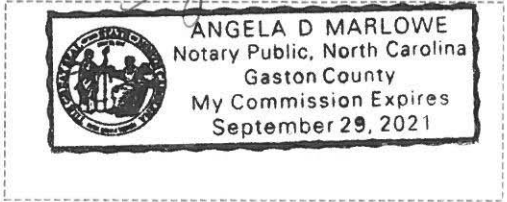

Enter Notary Stamp



Acceptance of Bid & Contract Award

Instructions: PART I of this form is to be completed by the Bidder and signed by its Authorized Representative. PART II will be completed by the AEPA Member Agency only upon the occasion of the bid award. If approved by AEPA, the Bidder is required to produce a copy of the document for each of the AEPA Member Agency with which it contracts.

PART I: BIDDER

In compliance with the Invitation for Bid (IFB), the undersigned warrants that I/we have examined all Instructions to Bidders, associated documents, and being familiar with all of the conditions of the bid, hereby offer and agree to furnish all labor, materials, supplies and equipment incurred in compliance with all terms, conditions, specifications and amendments associated with this IFB and any written exceptions to the bid. Signature also certifies understanding and compliance with the certification requirements of the AEPA Member Agency's Terms and Conditions and/or Special Terms and Conditions. The undersigned understands that their competence, ability, capacity and obligations to offer and provide the proposed tangible personal property, professional services, construction services and other services on behalf of the Bidder Partner as well as other factors of interest to the AEPA Member Agency as stated in the evaluation section, will be a consideration in making the award.

Business Name	<u>Husquarna Professional Products</u>	Date	<u>9/12/2019</u>
Address	<u>9335 Harris Corners Pkwy #500</u>	City, State Zip	<u>Charlotte, NC, 28269</u>
Contact Person	<u>Jacob Breig</u>	Title	<u>Government Sales Manager</u>
Authorized Signature	<u>[Signature]</u>	Title	<u>VP Sales VP</u>
Email	<u>jake.breig@husquarnagroup.com</u>	Phone	<u>704-340-7367</u>

PART II: AWARDING MEMBER AGENCY

Your bid response for the above identified bid is hereby accepted. As a Bidder Partner you are now bound to offer and provide the products and services identified within this IFB, your response and approved by AEPA, including all terms, conditions, specifications, exceptions and amendments. As Bidder Partner, you are hereby not to commence any billable work or provide any products or services under this contract until an executed purchase order is received from the AEPA Member Agency or Participating Entities. The intent of this contract is to constitute the final and complete agreement between the AEPA Member Agency and Bidder Partner, and no other agreements, oral or otherwise, regarding the subject matter of this contract, shall bind any of the parties hereto. No change or modification of this contract shall be valid unless in writing and signed by both parties to this contract. If any provision of this contract is deemed invalid or illegal by any appropriate court of law, the remainder of this contract shall not be affected thereby. The initial term of this contract shall be for up to fifteen (15) months and will commence on the date indicated below and continue until February 28, 2021, unless terminated, canceled or extended. By mutual written agreement as warranted, the contract may be extended month by month up to six (6) months or for three (3) additional 12-month periods.

Awarding Agency _____

Authorized Representative _____

Awarded this	day of	Contract Number
Contract to commence		
(Member Agency to select)		Or March 1, 2020

Bid Checklist

Instructions: Utilize the checklist below, reviewing to confirm that all the required documents have been uploaded to Public Purchase, in their specified/required format, by the due date and time listed for this IFB. Bid submissions not following the specified/required format may result as being marked non-responsive and may not be considered for evaluation. Bidders are reminded that failure to follow, comply with, and adhere to the enclosed instructions of this solicitation may result in their response being deemed non-responsive. AEPA, its Member Agencies, affiliate agencies and authorized representatives are not responsible for bid proposals that are incomplete, unreadable, or received after the IFB deadline submission date.

"X"	Document Title, Uploaded to Public Purchase <i>(Bidder must submit documents in the required title/format)</i>	Format of Uploaded Document	Notes
	Bid Bond – if Required, see Part B if applicable.	Upload PDF copy. The original <u>must be</u> received by Oakland Public Schools by due date and time.	Send to Oakland Public Schools.
X	Part C – State Specific Forms – <i>Name of Bidding Company</i>	Single, Scanned PDF	Required. Signatures Required.
X	Part D - Questionnaire – <i>Name of Bidding Company</i> Includes: <ul style="list-style-type: none"> • Company Information • Service Questionnaire • Exceptions • Deviations 	Single, Scanned PDF	Required.
X	Part E – Signature Forms – <i>Name of Bidding Company</i> Includes: <ul style="list-style-type: none"> • Uniform Guidance “EDGAR” Certification • Bid Affidavit • Acceptance of Bid & Contract Award 	Single, Scanned PDF	Required. Signatures required.
X	Part F – Pricing Schedule – <i>Name of Bidding Company</i>	Excel Workbook	Required.
X	Exhibit A – Annual Report/Letter of Credit – <i>Name of Bidding Company</i>	Scanned PDF	Required. Not provided by AEPA, Bidder Created
X	Exhibit B – Marketing Plan – <i>Name of Bidding Company</i>	Scanned PDF	Optional. Not provided by AEPA, Bidder Created
X	Exhibit C – Warranties, Additional Services – <i>Name of Bidding Company</i>	Scanned PDF	Optional. Not provided by AEPA, Bidder Created
	Exhibit D – Additional Discounts – <i>Name of Bidding Company</i>	Scanned PDF	Optional. Not provided by AEPA, Bidder Created



Part F.1 – Catalog Discount for Items in a Commercially Available Catalog

AEPA #020-E Lawn & Groundskeeping Equipment

Bidding Company Name:

Husqvarna Professional Products Inc.

Name of Catalog:

(This must be the catalog in effect as of the bid date)

Husqvarna Catalog 9.16.19

Note: Groupings to be defined by Bidder and can be by sub-category, manufacturer, etc.

Part F.1 is a REQUIRED FORM

No.	Grouping of Discount	Discount Offered for This Grouping	Comments
1	Z500 Zero Turn Mowers	30%	Z500 Series Zero Turn Mowers
2	Zero Turn Mowers	20%	Z100, Z200, Z400 (Commercial), MZ, and MZ-T (Commercial) Zero Turn Mowers
3	Lawn Tractors	20%	All lawn tractors included in Non-Core Price Schedule



**Part F.2A – Core List Price Schedule
AEPA #020-E Lawn & Groundskeeping Equipment**

INSTRUCTIONS: Complete the following information for all core items listed below. These are higher usage items and it is anticipated that deeper discounts will be bid for these items. In the event a new catalog or manufacturer's price list changes during the contract term, the Bid Discount Percentage would not exceed the bid discount percentage.
Please be sure to set the 'Print Area' PRIOR to submitting your bid response.

NOTE: The Net Effective Price MUST be consistent with the percentage discounts listed on the F.1 tab. Failure to have price correspond may be cause for rejection of your offer.

Part F.2A is a REQUIRED FORM

Bidding Company Name:		Husqvarna Professional Products Inc.					Catalog Name:			Core List	
No.	Product Category	Product Description	Manufacturer	Manufacturer SKU	Vendor SKU	Unit of Measure	Catalog List Price	Bid Discount Percentage	Net Effective Bid Price	Comments	No.
1	Turf Vehicles & Attachments	Utility Vehicle/Tractor: A gas or diesel-powered all-purpose conveyance, capable of accepting multiple types of attachments for turf management and landscaping tasks. Uses drop-bar, pivot-pin, or three-point hitches for attachments. Engine strength of approximately 60 hp. Fuel capacity of approximately 15 gallons. Forward ground speed of approximately 20 mph. Includes hydraulics and lift capacity for approximately 2,200 pounds. Configured as base-vehicle, stock without any options. An example of a machine meeting these specifications would be the Toro Outcross 960 Turf Utility Vehicle or equivalent.				Each			\$ -		1
2	Turf Vehicles & Attachments	Light Utility Vehicle: A gas-powered grounds and turf crossover vehicle, capable of accepting attachments and multiple types of configurations, such as cabs, beds, seat extensions, lifts, and racks. Powered by an engine, sized approximately at 430cc with a fuel tank of approximately five gallons. Forward ground speed of approximately 16 mph. Towing capacity of approximately 1,500 pounds. Hydraulic disk brakes. Provide pricing for a vehicle configured with four-person bench seating, windshield, and four-foot flat bed, no canopy. An example of a machine meeting these specifications would be the Toro Gas-Powered Workman GTX or equivalent.				Each			\$ -		2
3	Turf Vehicles & Attachments	Reel Mower Gang Attachment with Seven Blades: Mowing width of approximately 14 feet. Variable height adjustments. Capable of mowing approximately 10.5 acres per hour for semi-formal cuts. An example of a machine meeting these specifications would be the Toro Reelmaster Model 01007, configured as 16" diameter w/ Semi-pneumatic Wheels, Model 01304 or equivalent.				Each			\$ -		3

Bidding Company Name:		Husqvarna Professional Products Inc.					Catalog Name:				Core List	
No.	Product Category	Product Description	Manufacturer	Manufacturer SKU	Vendor SKU	Unit of Measure	Catalog List Price	Bid Discount Percentage	Net Effective Bid Price	Comments	No.	
4	Turf Vehicles & Attachments	Pull-Behind, Leaf and Debris Blower. Powered by an air-cooled engine with approximately 25 hp. Multi-directional blower chute. Axial flow, turbine-type fan assembly with blades approximately 14-inches wide. Category One, lawn-tractor style hitch. An example of a machine meeting these specifications would be the Toro CPro Force Series Debris Blower Model 4455Z or equivalent.				Each			\$ -		4	
5	Wide-Area Mowers	Large Area, Sit-On Reel Mower: Minimum Cut Swath of Seven Feet Wide: Suitable for sports fields and golf greens. Constructed with steel, steel tube framing, and/or welded steel. Powered by a diesel engine of approximately 21 hp with a fuel tank of approximately seven gallons. Forward mow speed of approximately six mph. Hydraulic reel drive. Accepts attachments. An example of a machine meeting these specifications would be the Toro Reelmaster 2400-D or equivalent.				Each			\$ -		5	
6	Wide-Area Mowers	Large Area, Sit-On Rotary Mower, Minimum Cut Swath of 11 Feet Wide: Suitable for rougher cut on fields, playgrounds, and greenscapes. Deck constructed with welded steel. Powered by a diesel engine of approximately 55 hp with a fuel tank of approximately 20 gallons. Forward mow speed of approximately eight mph. Multiple blades and decks. Four-wheel drive. Safe for hills. Open air seating; no cab. An example of a machine meeting these specifications would be the Toro Groundmaster Model 4000-D or equivalent.				Each			\$ -		6	
7	Walk-Behind Mowers	Walk-Behind, Floating Deck, Cut Swath between 50 and 55 inches: Cutting swath between 50 and 55 inches. Twin lever steering controls. Two to three rotary blades. Steel deck construction. Powered by a gas engine of approximately 18 hp with a fuel tank of approximately five gallons. Forward groundspeed of approximately six mph. An example of a machine meeting these specifications would be the 52-inch Toro Floating Deck Hydro Drive Twin-Lever Model 30489 or equivalent.				Each			\$ -		7	

Bidding Company Name:			Husqvarna Professional Products Inc.				Catalog Name:				Core List	
No.	Product Category	Product Description	Manufacturer	Manufacturer SKU	Vendor SKU	Unit of Measure	Catalog List Price	Bid Discount Percentage	Net Effective Bid Price	Comments	No.	
8	Walk-Behind Mowers	Walk-Behind, Fixed Deck, T-Bar Steering, Cut Swath between 48 and 52-Inches: Cutting swath between 48 to 52 inches. Preferred T-bar steering controls. Three rotary blades. Steel deck construction. Powered by a gas engine of approximately 14 hp with fuel tank of approximately five gallons. Forward groundspeed of approximately six mph. An example of a machine meeting these specifications would be the 48-inch Toro Fixed Deck Gear Drive T-Bar Model 39678 or equivalent.				Each			\$ -		8	
9	Walk-Behind Mowers	Walk-Behind, Fixed Deck, Cut Swath of 35 inches, California Compliant: Cutting swath of approximately 35 inches. Two rotary blades. Pistol grip steering. Recoil starter. Powered by a gas engine of approximately 14 hp with a fuel tank of approximately five gallons. Forward groundspeed of approximately six mph. Compliant with California Air Resource Board emission requirements. An example of a machine meeting these specifications would be the Toro Fixed Deck Hydro Drive Pistol Grip Model 39934 or equivalent.				Each			\$ -		9	
10	Stand-On Mowers	Stand-On, Low Gravity, EFI, Cut Swath of 60 Inches: Low enter of gravity making machine suitable and safe on hills and slopes. Cutting swath of approximately 60 inches. Zero-turn capability. Rotary blades. Steel or welded-steel deck construction. Twin-lever steering. Powered by a fuel-injection, gas engine of approximately 25 hp with fuel tank of approximately 10 gallons. Forward groundspeed of approximately 10 mph. An example of a machine meeting these specifications would be the Toro GrandStand 60" EFI Model 74513 or equivalent.	Husqvarna V554, 24.5 HP Kawasaki FX751V, 54", 7 Ga. Fab, 12cc Parker	967672601	N/A	Each	\$ 8,999.99	20%	\$ 7,199.99		10	
11	Stand-On Mowers	Economy, Stand-On, Narrow Cut Swath of 36 Inches, California Compliant: Cutting swath of approximately 36 inches. Rotary blades. Steel deck construction. Twin-lever steering controls. Powered by a gas engine of approximately 15 hp with fuel tank of approximately eight gallons. Forward groundspeed of approximately eight mph. Compliant with California Air Resources Board emission requirements. An example of a machine meeting these specifications would be the Toro GrandStand 36" Model 74534 CARB or equivalent.	Husqvarna V548, 24.5 HP Kawasaki FX751V, 48", 7 Ga. Fab, 12cc Parker	967672501	N/A	Each	\$ 8,899.99	20%	\$ 7,119.99		11	

Bidding Company Name:			Husqvarna Professional Products Inc.					Catalog Name:			Core List		
No.	Product Category	Product Description	Manufacturer	Manufacturer SKU	Vendor SKU	Unit of Measure	Catalog List Price	Bid Discount Percentage	Net Effective Bid Price	Comments	No.		
12	Zero-Turn Mowers	Zero-Turn, Sit-On, Cut Swath of 48 to 50 inches; Heavy Duty Deck: Cutting swath of approximately 48 to 50 inches. Rotary blades. Extra heavy-duty steel deck construction, such as 10-gauge steel. Pro-controlled damper steering controls. Powered by a gas engine of approximately 22 hp with fuel tank of approximately five gallons. Forward groundspeed of approximately eight mph. An example of a machine meeting these specifications would be the Toro TimeCutter HD Zero Turn Mower Model 75201 or equivalent.	Husqvarna Z448, 22 HP Kawasaki FS, 48" FAB	967984601	N/A	Each	\$ 5,999.99	20%	\$ 4,799.99		12		
13	Zero-Turn Mowers	Zero-Turn, Sit-On, Cut Swath of 60-inches: Cutting swath of 60 inches or more. Rotary blades. Steel deck construction. Steering controls to be standard to brand. Powered by a gas engine of approximately 25 hp with fuel tank of approximately seven gallons. Forward groundspeed of approximately eight mph. An example of a machine meeting these specifications would be the Toro TITAN® 1500 Series Zero Turn Mower, Model 74452 or equivalent.	Husqvarna Z560, 25.5 HP Kawasaki FX751V, 60in/10ga Fab, ZT4400	967678401	N/A	Each	\$ 9,299.99	30%	\$ 6,509.99		13		
14	Zero-Turn Mowers	Zero-Turn, Sit-On with Collection Apparatus, Cut Swath of 48 to 50 inches: Cutting Swath of approximately 48 inches. Rotary blades. Steel or welded-steel deck. Hand-controlled steering levers. Powered by a gas engine of approximately 25 hp with a fuel tank of approximately seven gallons. Forward groundspeed of approximately seven mph. Includes a rear discharge and collection apparatus to collect clippings of at least nine bushels. An example of a machine meeting these specifications would be the Toro 8000 Series Model 74313 or equivalent.	Husqvarna Z554X, 27.5 HP Yamaha MX825V, 54in/7ga Fab, ZT5400, Susp Seat, with Z554X 9 Bushel Collection System	967930001, 967322401	N/A	Each	\$ 13,398.99	27%	\$ 9,739.14	Pricing is reflective of 30% off the Z554X (Zero Turn), and 15% off the Collection System (Attachments & Accessories)	14		
15	Small Mowers & Grounds Tools	Narrow-Width, Push Mower, Narrow Cut Swath of 21 inches: Cutting swath of approximately 21 inches. Single rotary blade. Aluminum alloy or steel construction. Manual push driven. Powered by a small gas motor with a fuel tank of approximately one-half gallon. Either blade brake control or zone start. Rear discharge and bagging capability to ensure narrow-space mowing capability. An example of a machine meeting these specifications would be the Toro Heavy Duty, Zone Start, Toro OHV Engine, Model 22289 or equivalent.				Each			\$ -		15		

Bidding Company Name:			Husqvarna Professional Products Inc.					Catalog Name:			
No.	Product Category	Product Description	Manufacturer	Manufacturer SKU	Vendor SKU	Unit of Measure	Catalog List Price	Bid Discount Percentage	Net Effective Bid Price	Comments	No.
16	Small Mowers & Grounds Tools	<p>Narrow Width, Self-Propelled Mower, California Compliant: Cutting swath of approximately 21 inches. Single rotary blade. Aluminum alloy or steel construction. Three-speed, self-propelled drive. Blade brake control. Powered by a small gas motor with a one-gallon fuel tank. Top forward ground speed of approximately four mph. Compliant with California Air Resources Board emission requirements. An example of a machine meeting these specifications would be the Toro Heavy Duty, Self-Propelled, BBC, with Kawasaki Engine Model 22298 or equivalent.</p>				Each			\$ -		16
17	Small Mowers & Grounds Tools	<p>Light-Duty, Battery-Powered Chain Saw: Suitable for large-trunked brush and tree branch trimming. Chain bar length for cutting swath of at least 14 inches. Brushless DC motor. Battery rating of 40v maximum & 36v nominal. Recharge time of approximately 60 minutes. No-pull start. An example of a machine meeting these specifications would be the Toro PowerPlex 40V MAX 14" Chainsaw Model 51880 or equivalent.</p>	Husqvarna - 120j, 14", 3/8 pitch, .043 gauge Batt Chainsaw kit w/batt & charger	967098102	N/A	Each	\$ 259.99	20%	\$ 207.99		17
18	Small Mowers & Grounds Tools	<p>Gas-Powered, String Trimmer: Suitable for turf edging, low-lying branches, and small shrubs. Cutting width of 18 inches. Dual-Line, bump feed cutting head. Supports minimum cord-line thickness of 2mm; straight handle. Extended reach is desirable. Powered by a small two-cycle, full-crank gas engine. Compliant with California Air Resources Board emission standards. An example of a machine meeting these specifications would be the Toro Straight Shaft Gas Trimmer Model 51978 or equivalent.</p>	Husqvarna 129LK, 28cc detachable shaft trimmer, LK attachments (power head single pac)	967680502	N/A	Each	\$ 169.99	20%	\$ 135.99		18
19	Small Mowers & Grounds Tools	<p>Gas Powered Leaf Blower: Suitable for clearing sidewalks, parking lots, planters, and small lawns. Air-power speed of approximately 150 mph. Powered by a small, commercial-grade two-cycle engine, capable of being hand carried. Motor integrated with handle; not on a backpack. Recoil starting mechanism. Includes vacuum and shredding capabilities. An example of a machine meeting these specifications would be the Toro Gas Blower Vac Model 51988 or equivalent.</p>	Husqvarna 125BVX, 28 cc handheld blower with vac kit, 1.1 hp., 425 cfm/170 mph	952711902	N/A	Each	\$ 199.99	20%	\$ 159.99		19



Part F.2-B – Non-Core Price Schedule AEPA #020-E Lawn & Groundskeeping Equipment

INSTRUCTIONS: Download the Net Effective Bid Price and respective information for all line items, except the core items (listed on F.2A) in the entire catalog. Use a separate spreadsheet for each catalog. Please be sure to set the 'Print Area' PRIOR to submitting your bid response.

NOTE: The Net Effective Price MUST be consistent with the percentage discounts listed on the F.1 tab. Failure to have price correspond may be cause for rejection of your offer.

Part F.2-B is a REQUIRED FORM

Bidding Company Name:			Husqvarna Professional Products Inc			Catalog Name:			Non-Core Catalog		
No.	Product Category	Product Description	Manufacturer	Manufacturer SKU	Vendor SKU	Unit of Measure	Catalog List Price	Bid Discount Percentage	Net Effective Bid Price	Comments	No.
4	2500 Zero Turn Mowers	Z554X	Husqvarna	967930101		Each	\$ 11,299.99	30.0%	\$ 7,909.99	29 HP Yamaha MX775V EFI, 54in/7ga F	4
5	2500 Zero Turn Mowers	Z554X	Husqvarna	967930001		Each	\$ 10,999.99	30.0%	\$ 7,699.99	27.5 HP Yamaha MX825V, 54in/7ga Fa	5
6	2500 Zero Turn Mowers	Z560X	Husqvarna	967878401		Each	\$ 9,299.99	30.0%	\$ 6,509.99	26.5 HP Kawasaki FX751V, 60in/10ga	6
7	2500 Zero Turn Mowers	Z560X	Husqvarna	967930301		Each	\$ 11,899.99	30.0%	\$ 8,329.99	27.5 HP Yamaha MX825V, 60in/7ga Pal	7
8	2500 Zero Turn Mowers	Z572X	Husqvarna	967930501		Each	\$ 13,399.99	30.0%	\$ 9,379.99	33 HP Yamaha MX825V EFI, 72in/7ga F	8
9	2500 Zero Turn Mowers	Z560X	Husqvarna	967930401		Each	\$ 12,599.99	30.0%	\$ 8,819.99	31 HP Yamaha MX800V EFI, 60in/7ga F	10
10	2500 Zero Turn Mowers	Z572X	Husqvarna	967669801		Each	\$ 13,299.99	30.0%	\$ 9,309.99	31 HP Kawasaki FX921V, 72in/7ga Pab	11
11	2500 Zero Turn Mowers	Z560X	Husqvarna	967669701		Each	\$ 12,499.99	30.0%	\$ 8,749.99	31 HP Kawasaki FX921V, 60in/7ga Pab	12
12	Zero Turn Mowers	Z448	Husqvarna	967984601		Each	\$ 5,999.99	20.0%	\$ 4,799.99	22 HP Kawasaki FS, 48" FAB	13
13	Zero Turn Mowers	Z454 50ST	Husqvarna	967984701		Each	\$ 6,499.99	20.0%	\$ 5,199.99	22 HP Kawasaki FS, 54" FAB, 50 STATE	14
14	Zero Turn Mowers	Z460	Husqvarna	967984801		Each	\$ 6,999.99	20.0%	\$ 5,599.99	23 HP Kawasaki FS, 60" FAB	15
15	Zero Turn Mowers	Z454X	Husqvarna	967985001		Each	\$ 8,499.99	20.0%	\$ 6,799.99	22 HP Kawasaki FX, 54" FAB	16
16	Zero Turn Mowers	Z460X	Husqvarna	967985101		Each	\$ 8,999.99	20.0%	\$ 7,199.99	23.5 HP Kawasaki FX, 60" FAB	17
17	Zero Turn Mowers	Z254F Intek	Husqvarna	967988001		Each	\$ 2,699.99	20.0%	\$ 2,159.99	22 HP Intek, 54" Stamped/Reinforced	18
18	Zero Turn Mowers	Z254F	Husqvarna	967954002		Each	\$ 2,399.99	20.0%	\$ 1,919.99	23 HP Kawasaki, 54 ClearCut, 6" Caster	19
19	Zero Turn Mowers	Z242F	Husqvarna	967953802		Each	\$ 2,799.99	20.0%	\$ 2,239.99	18 HP Kawasaki FR, 42 ClearCut, 6" Cast	20
20	Zero Turn Mowers	Z142	Husqvarna	967924801		Each	\$ 2,599.99	20.0%	\$ 2,079.99	17 HP Kohler, 42" Stamped, 2 Blade	21
21	Zero Turn Mowers	Z248F	Husqvarna	967924901		Each	\$ 2,899.99	20.0%	\$ 2,319.99	21.5 HP Kawasaki FR, 48 ClearCut @ 6"	22
22	Zero Turn Mowers	Z242F CARB	Husqvarna	967953803		Each	\$ 2,899.99	20.0%	\$ 2,319.99	18 HP Kawasaki FR, 42 ClearCut, 6" Cast	23
23	Zero Turn Mowers	Z254	Husqvarna	967324101		Each	\$ 2,799.99	20.0%	\$ 2,239.99	24 HP Endurance, 54" Stamped/Reinfor	24
24	Zero Turn Mowers	Z246	Husqvarna	967271501		Each	\$ 2,699.99	20.0%	\$ 2,159.99	20 HP Endurance, 46" Stamped / Reinfor	25
25	Zero Turn Mowers	Z254	Husqvarna	967844601		Each	\$ 2,899.99	20.0%	\$ 2,319.99	26 HP Kohler 7000, 54" Stamped / Reinf	26
26	Zero Turn Mowers	Z248F CARB	Husqvarna	967953903		Each	\$ 2,999.99	20.0%	\$ 2,399.99	21.5 HP Kawasaki FR, 48 ClearCut @ 6"	27
27	Zero Turn Mowers	Z254F	Husqvarna	967844901		Each	\$ 3,299.99	20.0%	\$ 2,639.99	26 HP Kohler 7000, 54 ClearCut, 6" Cast	28
28	Zero Turn Mowers	Z248F	Husqvarna	967844801		Each	\$ 3,199.99	20.0%	\$ 2,559.99	26 HP Kohler 7000, 48 ClearCut @ 6" C	29
29	Zero Turn Mowers	M254	Husqvarna	967696001		Each	\$ 4,999.99	20.0%	\$ 3,999.99	23 HP Kohler Confidant, 54" ClearCut, 3	30
30	Zero Turn Mowers	M254+ROPS	Husqvarna	967953701		Each	\$ 5,299.99	20.0%	\$ 4,239.99	24 HP Kawasaki, 54" ClearCut @ deck, 31	31
31	Zero Turn Mowers	M261+ROPS	Husqvarna	967262801		Each	\$ 4,699.99	20.0%	\$ 3,759.99	23 HP Kohler 7000 H/D Filter, 48" Clear	32
32	Zero Turn Mowers	M261	Husqvarna	967277503		Each	\$ 5,499.99	20.0%	\$ 4,399.99	24 HP Kawasaki FR, 61" Fabricated dec	33
33	Zero Turn Mowers	M261	Husqvarna	967277501		Each	\$ 5,199.99	20.0%	\$ 4,159.99	27 HP Endurance, 61" Fabricated deck	34
34	Zero Turn Mowers	M248	Husqvarna	967262701		Each	\$ 4,799.99	20.0%	\$ 3,839.99	23 HP Kohler 7000 H/D Filter, 48" Clear	35
35	Zero Turn Mowers	Z246	Husqvarna	967665401		Each	\$ 3,999.99	20.0%	\$ 3,199.99	18.5 HP Kawasaki FR600V, 46" Stamp	36
36	Zero Turn Mowers	Z248F	Husqvarna	967665801		Each	\$ 4,999.99	20.0%	\$ 3,999.99	23 HP Kawasaki FR691V, 48" ClearCut	37
37	Zero Turn Mowers	Z242F	Husqvarna	967665701		Each	\$ 4,999.99	20.0%	\$ 3,999.99	21.5HP Kawi FR651V, 42" ClearCut dec	38
38	Zero Turn Mowers	Z242E	Husqvarna	967665601		Each	\$ 4,999.99	20.0%	\$ 3,999.99	21.5 HP Kawi FR651V, Cast Aluminum	39
39	Lawm Tractors	TS 348D	Husqvarna	960430285		Each	\$ 3,299.99	20.0%	\$ 2,639.99	24 Kohler, 48" ClearCut™ @ w/GI Spind	40
40	Lawm Tractors	TS 354XD	Husqvarna	960430290		Each	\$ 3,799.99	20.0%	\$ 3,039.99	26HP Kohler w/Smart Choke, 54" Clear	41
41	Lawm Tractors	TS 348X	Husqvarna	960430295		Each	\$ 3,599.99	20.0%	\$ 2,879.99	26HP Kohler w/Smart Choke, 54" Clear	42
42	Lawm Tractors	TS 354D	Husqvarna	960430282		Each	\$ 3,599.99	20.0%	\$ 2,879.99	26HP Kohler w/Smart Choke, 48" Clear	43
43	Lawm Tractors	TS 354D	Husqvarna	960450066		Each	\$ 3,699.99	20.0%	\$ 2,959.99	25HP Kohler, 54" ClearCut™, Elec PTO	44
44	Lawm Tractors	YTH185-42	Husqvarna	960430256		Each	\$ 1,699.99	20.0%	\$ 1,359.99	18.5HP B&S Intek single, 42" Reinforced	47
45	Lawm Tractors	YTH185-42 CARB	Husqvarna	960450060		Each	\$ 1,799.99	20.0%	\$ 1,439.99	18.5HP B&S 42" Reinforced deck, Man H	48
46	Lawm Tractors	YTH24V48 CARB	Husqvarna	960450068		Each	\$ 2,099.95	20.0%	\$ 1,679.96	24HP B&S Intek, 48" Reinforced deck, H	49
47	Lawm Tractors	YTH22V48	Husqvarna	960430258		Each	\$ 1,899.99	20.0%	\$ 1,519.99	22HP B&S Intek, 46" Reinforced Hydro	50
48	Lawm Tractors	YTH24V48 CARB	Husqvarna	960450062		Each	\$ 1,999.99	20.0%	\$ 1,599.99	22HP B&S Intek, 46" Reinforced deck, H	51
49	Lawm Tractors	YTH24V54	Husqvarna	960430255		Each	\$ 2,199.95	20.0%	\$ 1,759.96	24HP B&S, 54" Reinforced deck, Hydro, S	52
50	Lawm Tractors	YTH24V54 CARB	Husqvarna	960450069		Each	\$ 2,299.95	20.0%	\$ 1,839.96	24HP B&S, 54" Reinforced deck, Hydro, S	53
51	Lawm Tractors	TS 242	Husqvarna	960430306		Each	\$ 2,599.99	20.0%	\$ 2,079.99	22HP Kohler w/SC, 42" ClearCut™, del	54
52	Lawm Tractors	LGT48DXL	Husqvarna	960450065		Each	\$ 2,699.95	20.0%	\$ 2,159.96	25HP Kohler, 48" ClearCut™, Elec PTO	55

Bidding Company Name:			Catalog Name:		Non-Core Catalog						
No.	Product Category	Product Description	Manufacturer	Manufacturer SKU	Vendor/SKU	Unit of Measure	Catalog List Price	Bid Discount Percentage	Net Effective Bid Price	Comments	No.
56	Stand-On Zero Turn Units	V548	Husqvarna	967672501		Each	\$ 8,999.99	20.0%	\$ 7,199.99	24.5 HP Kawasaki FX751V, 48", 7 Ga. Fe	57
57	Stand-On Zero Turn Units	V554	Husqvarna	967672601		Each	\$ 8,999.99	20.0%	\$ 7,199.99	24.5 HP Kawasaki FX751V, 54", 7 Ga. Fe	58
58	Handheld Equipment	572XP	Husqvarna	966733108		Each	\$ 1,019.99	20.0%	\$ 815.99	24", 3/8 pitch, 050 ga. 70.7cc chainsaw	59
59	Handheld Equipment	572XP	Husqvarna	966733109		Each	\$ 1,019.99	20.0%	\$ 815.99	24", 3/8 pitch, 058 ga. 70.7cc chainsaw	60
60	Handheld Equipment	572XP	Husqvarna	966733113		Each	\$ 1,029.99	20.0%	\$ 823.99	28", 3/8 pitch, 063 ga. 70.7cc chainsaw	61
61	Handheld Equipment	572XP	Husqvarna	966733111		Each	\$ 1,029.99	20.0%	\$ 823.99	28", 3/8 pitch, 050 ga. 70.7cc chainsaw	62
62	Handheld Equipment	572XP	Husqvarna	966733112		Each	\$ 1,029.99	20.0%	\$ 823.99	28", 3/8 pitch, 058 ga. 70.7cc chainsaw	63
63	Handheld Equipment	390XP	Husqvarna	965060720		Each	\$ 1,179.99	20.0%	\$ 943.99	20", 3/8 pitch, 050 ga. 88cc chainsaw	64
64	Handheld Equipment	390XP	Husqvarna	965060730		Each	\$ 1,179.99	20.0%	\$ 943.99	20", 3/8 pitch, 058 ga. 88cc chainsaw	65
65	Handheld Equipment	390XP	Husqvarna	965060734		Each	\$ 1,199.99	20.0%	\$ 959.99	24", 3/8 pitch, 050 ga. 88cc chainsaw	66
66	Handheld Equipment	390XP	Husqvarna	965060734		Each	\$ 1,199.99	20.0%	\$ 959.99	24", 3/8 pitch, 058 ga. 88cc chainsaw	67
67	Handheld Equipment	390XP	Husqvarna	965060749		Each	\$ 1,199.99	20.0%	\$ 959.99	24", 3/8 pitch, 063 ga. 88cc chainsaw	68
68	Handheld Equipment	572XP	Husqvarna	966451907		Each	\$ 1,059.99	20.0%	\$ 847.99	32", 3/8 pitch, 063 ga. 70.7cc chainsaw	69
69	Handheld Equipment	555	Husqvarna	966451907		Each	\$ 699.99	20.0%	\$ 559.99	20", 3/8 pitch, 058 ga. 59.8cc chainsaw	70
70	Handheld Equipment	555	Husqvarna	966451906		Each	\$ 699.99	20.0%	\$ 559.99	20", 3/8 pitch, 050 ga. 59.8cc chainsaw	71
71	Handheld Equipment	390XP	Husqvarna	965060728		Each	\$ 1,229.99	20.0%	\$ 983.99	28", 3/8 pitch, 058 ga. 88cc chainsaw	72
72	Handheld Equipment	390XP	Husqvarna	965060738		Each	\$ 1,229.99	20.0%	\$ 983.99	28", 3/8 pitch, 058 ga. 88cc chainsaw	73
73	Handheld Equipment	390XP	Husqvarna	965060750		Each	\$ 1,249.99	20.0%	\$ 999.99	32", 3/8 pitch, 050 ga. 88cc chainsaw	74
74	Handheld Equipment	390XP	Husqvarna	965060732		Each	\$ 1,249.99	20.0%	\$ 999.99	32", 3/8 pitch, 063 ga. 88cc chainsaw	75
75	Handheld Equipment	390XP	Husqvarna	965060714		Each	\$ 1,249.99	20.0%	\$ 999.99	32", 3/8 pitch, 063 ga. 88cc chainsaw	76
76	Handheld Equipment	555	Husqvarna	966451908		Each	\$ 719.99	20.0%	\$ 575.99	24", 3/8 pitch, 050 ga. 59.8cc chainsaw	77
77	Handheld Equipment	545 II	Husqvarna	9667690640		Each	\$ 579.99	20.0%	\$ 463.99	20", 325 pitch, 050 ga. 50.1cc chainsaw	78
78	Handheld Equipment	390XP	Husqvarna	965060751		Each	\$ 1,279.99	20.0%	\$ 1,023.99	36", 3/8 pitch, 063 ga. 88cc chainsaw	79
79	Handheld Equipment	535XP	Husqvarna	967893874		Each	\$ 429.99	20.0%	\$ 343.99	14", 3/8 pitch, 043 gauge XP batt chain	80
80	Handheld Equipment	17535IXP	Husqvarna	967893972		Each	\$ 429.99	20.0%	\$ 343.99	12", 3/8 pitch, 043 gauge Top Handle B	81
81	Handheld Equipment	525HF3S	Husqvarna	967207501		Each	\$ 459.99	20.0%	\$ 367.99	25.4cc 10 foot reach pro fixed hedge tri	82
82	Handheld Equipment	1435	Husqvarna	966997232		Each	\$ 329.99	20.0%	\$ 263.99	12", 3/8 pitch, 050 ga. 35.2cc top handl	83
83	Handheld Equipment	1435	Husqvarna	966997234		Each	\$ 349.99	20.0%	\$ 279.99	14", 3/8 pitch, 050 ga. 35.2cc top handl	84
84	Handheld Equipment	520HFE3	Husqvarna	967915812		Each	\$ 449.99	20.0%	\$ 359.99	40v 10 foot reach battery articulating h	85
85	Handheld Equipment	565	Husqvarna	966733906		Each	\$ 939.99	20.0%	\$ 751.99	20", 3/8 pitch, 050 ga. 70.7cc chainsaw	86
86	Handheld Equipment	565	Husqvarna	966733907		Each	\$ 939.99	20.0%	\$ 751.99	20", 3/8 pitch, 058 ga. 70.7cc chainsaw	87
87	Handheld Equipment	565	Husqvarna	966733908		Each	\$ 949.99	20.0%	\$ 759.99	24", 3/8 pitch, 050 ga. 70.7cc chainsaw	88
88	Handheld Equipment	565	Husqvarna	966733909		Each	\$ 949.99	20.0%	\$ 759.99	24", 3/8 pitch, 058 ga. 70.7cc chainsaw	89
89	Handheld Equipment	565	Husqvarna	966733910		Each	\$ 959.99	20.0%	\$ 767.99	28", 3/8 pitch, 050 ga. 70.7cc chainsaw	90
90	Handheld Equipment	525BES	Husqvarna	966733911		Each	\$ 959.99	20.0%	\$ 767.99	28", 3/8 pitch, 058 ga. 70.7cc chainsaw	91
91	Handheld Equipment	325HE3	Husqvarna	967176001		Each	\$ 319.99	20.0%	\$ 255.99	25.4cc flex drive, curved shaft, stick edg	92
92	Handheld Equipment	522L	Husqvarna	967343601		Each	\$ 499.99	20.0%	\$ 399.99	25.4cc 10 foot reach pro articulating he	93
93	Handheld Equipment	522L	Husqvarna	967343601		Each	\$ 379.99	20.0%	\$ 303.99	16", 3/8 pitch, 050 ga. 35.2cc top handl	94
94	Handheld Equipment	545 II	Husqvarna	967690601		Each	\$ 489.99	20.0%	\$ 391.99	POWERHEAD	95
95	Handheld Equipment	545 II	Husqvarna	967690636		Each	\$ 539.99	20.0%	\$ 431.99	16", 325 pitch, 050 ga. 50.1cc chainsaw	96
96	Handheld Equipment	545 II	Husqvarna	967690616		Each	\$ 539.99	20.0%	\$ 431.99	16", 325 pitch, 058 ga. 50.1cc chainsaw	97
97	Handheld Equipment	545 II	Husqvarna	967690638		Each	\$ 549.99	20.0%	\$ 439.99	18", 325 pitch, 050 ga. 50.1cc chainsaw	98
98	Handheld Equipment	530HP4	Husqvarna	967884610		Each	\$ 399.99	20.0%	\$ 319.99	40v fixed battery pole saw w/o battery	99
99	Handheld Equipment	520HDD60	Husqvarna	967915601		Each	\$ 449.99	20.0%	\$ 359.99	40V double side batt hedge trimmer, 24	100
100	Handheld Equipment	325HE4	Husqvarna	966787701		Each	\$ 549.99	20.0%	\$ 439.99	25.4cc 13 foot reach pro articulating he	101
101	Handheld Equipment	524LX	Husqvarna	967327001		Each	\$ 449.99	20.0%	\$ 359.99	25cc four stroke trimmer, detachable,	102
102	Handheld Equipment	525ES	Husqvarna	967175901		Each	\$ 399.99	20.0%	\$ 319.99	25.4cc steel drive, straight shaft stick e	103
103	Handheld Equipment	520HXL	Husqvarna	967916112		Each	\$ 299.99	20.0%	\$ 239.99	40V straight shaft battery trimmer w/o	104
104	Handheld Equipment	525L	Husqvarna	966781701		Each	\$ 299.99	20.0%	\$ 239.99	25.4cc professional trimmer, steel drive	105
105	Handheld Equipment	545 II	Husqvarna	967690618		Each	\$ 549.99	20.0%	\$ 439.99	18", 325 pitch, 058 ga. 50.1cc chainsaw	106
106	Handheld Equipment	570BFS	Husqvarna	966629501		Each	\$ 499.99	20.0%	\$ 399.99	65 cc frame throttle b/p blower, 770 cfm	107
107	Handheld Equipment	570BFS	Husqvarna	966629502		Each	\$ 499.99	20.0%	\$ 399.99	65 cc frame throttle b/p blower, 770 cfm	108
108	Handheld Equipment	525LSL	Husqvarna	966629402		Each	\$ 499.99	20.0%	\$ 399.99	65 cc tube throttle b/p blower, 770 cfm	109
109	Handheld Equipment	550KPG II	Husqvarna	967670601		Each	\$ 319.99	20.0%	\$ 255.99	25.4cc pro trimmer, steel dr. shaft, bickl	110
110	Handheld Equipment	550KPG II	Husqvarna	967690936		Each	\$ 669.99	20.0%	\$ 535.99	16", 325 pitch, 050 ga. 50.1cc heated h	111
111	Handheld Equipment	550XP II	Husqvarna	967690836		Each	\$ 599.99	20.0%	\$ 479.99	16", 325 pitch, 050 ga. 50.1cc chainsaw	112
112	Handheld Equipment	550XP II	Husqvarna	967690816		Each	\$ 599.99	20.0%	\$ 479.99	16", 325 pitch, 058 ga. 50.1cc chainsaw	113
113	Handheld Equipment	550KPG II	Husqvarna	967690938		Each	\$ 679.99	20.0%	\$ 543.99	18", 325 pitch, 050 ga. 50.1cc chainsaw	114
114	Handheld Equipment	560BFS	Husqvarna	966631201		Each	\$ 459.99	20.0%	\$ 367.99	65 cc frame throttle b/p blower, 632 cfm	115
115	Handheld Equipment	550XP II	Husqvarna	967690838		Each	\$ 609.99	20.0%	\$ 487.99	18", 325 pitch, 050 ga. 50.1cc chainsaw	116
116	Handheld Equipment	550XP II	Husqvarna	967690818		Each	\$ 609.99	20.0%	\$ 487.99	18", 325 pitch, 058 ga. 50.1cc chainsaw	117
117	Handheld Equipment	550XP II	Husqvarna	967690820		Each	\$ 619.99	20.0%	\$ 495.99	20", 325 pitch, 058 ga. 50.1cc chainsaw	118

Bidding Company Name:				Husqvarna Professional Products Inc				Catalog Name:				Non-Core Catalog			
No.	Product Category	Product Description	Manufacturer	Manufacturer SKU	Vendor SKU	Unit of Measure	Catalog List Price	Bid Discount Percentage	Net Effective Bid Price	Comments	No.				
118	Handheld Equipment	525LST	Husqvarna	967670701		Each	\$ 339.99	20.0%	\$ 271.99	25.4cc pro trimmer, hi torque steel dr.	119				
119	Handheld Equipment	560BTS	Husqvarna	966631102		Each	\$ 459.99	20.0%	\$ 367.99	65 cc tube throttle b/p blower, 632 cfm	120				
120	Handheld Equipment	530PPT5	Husqvarna	967885010		Each	\$ 495.99	20.0%	\$ 399.99	40v telescopic battery pole saw w/o bat	121				
121	Handheld Equipment	525RKT	Husqvarna	967175701		Each	\$ 399.99	20.0%	\$ 319.99	25.4cc bike handle steel drive brushcut	122				
122	Handheld Equipment	580BFS II	Husqvarna	967851401		Each	\$ 569.99	20.0%	\$ 455.99	76 cc frame throttle b/p blower, 936 cfm	123				
123	Handheld Equipment	580BFS II	Husqvarna	967851301		Each	\$ 569.99	20.0%	\$ 455.99	76 cc tube throttle b/p blower, 936 cfm	124				
124	Handheld Equipment	525LTK	Husqvarna	967148403		Each	\$ 399.99	20.0%	\$ 319.99	25.4cc detachable pro trimmer, 1.3hp.	125				
125	Handheld Equipment	535LTK	Husqvarna	967688102		Each	\$ 499.99	20.0%	\$ 399.99	34.6cc detachable pro trimmer.	126				
126	Handheld Equipment	525PFS	Husqvarna	967329201		Each	\$ 579.99	20.0%	\$ 463.99	25.4cc 16 foot reach split boom profess	127				
127	Handheld Equipment	525P4S	Husqvarna	967680203		Each	\$ 449.99	20.0%	\$ 359.99	40V Li-Ion handheld blower, 388cfm/1	128				
128	Handheld Equipment	430L5	Husqvarna	967329101		Each	\$ 299.99	20.0%	\$ 239.99	25.4cc 13 foot reach professional pole s	129				
129	Handheld Equipment	430L5	Husqvarna	966482501		Each	\$ 399.99	20.0%	\$ 319.99	29.5 cc professional trimmer, steel driv	130				
130	Handheld Equipment	543XP	Husqvarna	967146202		Each	\$ 529.99	20.0%	\$ 423.99	16", .325 pitch, .050 ga. 4.3.1cc chainsaw	131				
131	Handheld Equipment	545PR	Husqvarna	967637902		Each	\$ 849.99	20.0%	\$ 679.99	45.7cc bike handle pro brushcutter w/1	132				
132	Handheld Equipment	525BX	Husqvarna	967284202		Each	\$ 269.99	20.0%	\$ 215.99	25.4cc pro handheld blower, 459 cfm/1	133				
133	Handheld Equipment	543XP	Husqvarna	967146201		Each	\$ 499.99	20.0%	\$ 399.99	POWERHEAD	134				
134	Handheld Equipment	555	Husqvarna	966451909		Each	\$ 719.99	20.0%	\$ 575.99	24", 3/8 pitch, .058 ga. 59.8cc chainsaw	135				
135	Handheld Equipment	555	Husqvarna	966451901		Each	\$ 629.99	20.0%	\$ 503.99	POWERHEAD	136				
136	Handheld Equipment	562XP	Husqvarna	966570302		Each	\$ 749.99	20.0%	\$ 599.99	18", 3/8 pitch, .050 ga. 59.8cc chainsaw	137				
137	Handheld Equipment	562XP	Husqvarna	966570303		Each	\$ 749.99	20.0%	\$ 599.99	18", 3/8 pitch, .058 ga. 59.8cc chainsaw	138				
138	Handheld Equipment	7540XP	Husqvarna	967287614		Each	\$ 649.99	20.0%	\$ 519.99	14", 3/8 pitch, .050 ga. 37.7cc top handl	139				
139	Handheld Equipment	525R1X	Husqvarna	967175801		Each	\$ 449.99	20.0%	\$ 359.99	25.4cc loop handle steel drive brushcut	140				
140	Handheld Equipment	562XP	Husqvarna	966570304		Each	\$ 769.99	20.0%	\$ 615.99	20", 3/8 pitch, .050 ga. 59.8cc chainsaw	141				
141	Handheld Equipment	562XP	Husqvarna	966570305		Each	\$ 769.99	20.0%	\$ 615.99	20", 3/8 pitch, .058 ga. 59.8cc chainsaw	142				
142	Handheld Equipment	562XPG	Husqvarna	966570101		Each	\$ 779.99	20.0%	\$ 623.99	POWERHEAD	143				
143	Handheld Equipment	562XP	Husqvarna	966570306		Each	\$ 789.99	20.0%	\$ 631.99	24", 3/8 pitch, .050 ga. 59.8cc chainsaw	144				
144	Handheld Equipment	562XP	Husqvarna	966570315		Each	\$ 789.99	20.0%	\$ 631.99	24", 3/8 pitch, .058 ga. 59.8cc chainsaw	145				
145	Handheld Equipment	562XP	Husqvarna	966570322		Each	\$ 809.99	20.0%	\$ 647.99	28", 3/8 pitch, .050 ga. 59.8cc chainsaw	146				
146	Handheld Equipment	562XP	Husqvarna	966570323		Each	\$ 809.99	20.0%	\$ 647.99	28", 3/8 pitch, .058 ga. 59.8cc chainsaw	147				
147	Handheld Equipment	562XP	Husqvarna	966570328		Each	\$ 809.99	20.0%	\$ 647.99	28", 3/8 pitch, .063 ga. 59.8cc chainsaw	148				
148	Handheld Equipment	7540XP	Husqvarna	967287616		Each	\$ 679.99	20.0%	\$ 543.99	16", 3/8 pitch, .050 ga. 37.7cc top handl	149				
149	Handheld Equipment	565	Husqvarna	966733901		Each	\$ 869.99	20.0%	\$ 695.99	POWERHEAD	150				
150	Handheld Equipment	572XPG	Husqvarna	966733401		Each	\$ 1,029.99	20.0%	\$ 823.99	POWERHEAD	151				
151	Handheld Equipment	525PFS	Husqvarna	967329301		Each	\$ 629.99	20.0%	\$ 503.99	25.4cc 16 foot reach telescopic profess	152				
152	Handheld Equipment	562XP	Husqvarna	966570301		Each	\$ 719.99	20.0%	\$ 575.99	POWERHEAD	153				
153	Handheld Equipment	322HD60	Husqvarna	966568901		Each	\$ 399.99	20.0%	\$ 319.99	23" double sided hedge trimmer PGE	154				
154	Handheld Equipment	572XP	Husqvarna	966733101		Each	\$ 949.99	20.0%	\$ 759.99	POWERHEAD	155				
155	Handheld Equipment	555FX	Husqvarna	966629102		Each	\$ 1,349.99	20.0%	\$ 1,079.99	53.3cc forestry clearing saw with XT Ba	156				
156	Handheld Equipment	522HS75S	Husqvarna	967659302		Each	\$ 559.99	20.0%	\$ 447.99	30" single sided coarse cut hedge trim	157				
157	Handheld Equipment	522HD60S	Husqvarna	967658801		Each	\$ 529.99	20.0%	\$ 423.99	23" double sided hedge trimmer pro	158				
158	Handheld Equipment	522HD860S	Husqvarna	967658501		Each	\$ 529.99	20.0%	\$ 423.99	23" double sided hedge trimmer pro	159				
159	Handheld Equipment	522HD875S	Husqvarna	967658601		Each	\$ 559.99	20.0%	\$ 447.99	30" double sided coarse cut hedge trim	160				
160	Handheld Equipment	395XP	Husqvarna	965902709		Each	\$ 1,299.99	20.0%	\$ 1,039.99	32", 3/8 pitch, .050 ga. 94cc chainsaw	161				
161	Handheld Equipment	395XP	Husqvarna	965902735		Each	\$ 1,299.99	20.0%	\$ 1,039.99	32", 3/8 pitch, .063 ga. 94cc chainsaw	162				
162	Handheld Equipment	395XP	Husqvarna	965902772		Each	\$ 1,299.99	20.0%	\$ 1,039.99	32", 3/8 pitch, .058 ga. 94cc chainsaw	163				
163	Handheld Equipment	395XP	Husqvarna	965902710		Each	\$ 1,319.99	20.0%	\$ 1,055.99	36", 3/8 pitch, .063 ga. 94cc chainsaw	164				
164	Handheld Equipment	395XP	Husqvarna	965902720		Each	\$ 1,319.99	20.0%	\$ 1,055.99	36", 3/8 pitch, .058 ga. 94cc chainsaw	165				
165	Handheld Equipment	395XP	Husqvarna	965902739		Each	\$ 1,279.99	20.0%	\$ 1,023.99	28", 3/8 pitch, .050 ga. 94cc chainsaw	166				
166	Handheld Equipment	395XP	Husqvarna	965902765		Each	\$ 1,279.99	20.0%	\$ 1,023.99	28", 3/8 pitch, .058 ga. 94cc chainsaw	167				
167	Handheld Equipment	395XP	Husqvarna	965902763		Each	\$ 1,259.99	20.0%	\$ 1,007.99	24", 3/8 pitch, .058 ga. 94cc chainsaw	168				
168	Handheld Equipment	395XP	Husqvarna	965902737		Each	\$ 1,259.99	20.0%	\$ 1,007.99	24", 3/8 pitch, .050 ga. 94cc chainsaw	169				
169	Handheld Equipment	395XP	Husqvarna	965902771		Each	\$ 1,279.99	20.0%	\$ 1,023.99	28", 3/8 pitch, .063 ga. 94cc chainsaw	170				
170	Handheld Equipment	395XP	Husqvarna	965902762		Each	\$ 1,239.99	20.0%	\$ 991.99	20", 3/8 pitch, .058 ga. 94cc chainsaw	171				
171	Handheld Equipment	395XP	Husqvarna	965902749		Each	\$ 1,239.99	20.0%	\$ 991.99	20", 3/8 pitch, .050 ga. 94cc chainsaw	172				
172	Handheld Equipment	390XP	Husqvarna	965060701		Each	\$ 1,149.99	20.0%	\$ 919.99	POWERHEAD	173				
173	Handheld Equipment	395XP	Husqvarna	965902770		Each	\$ 1,299.99	20.0%	\$ 1,039.99	24", 3/8 pitch, .063 ga. 94cc chainsaw	174				
174	Handheld Equipment	395XP	Husqvarna	965902701		Each	\$ 1,199.99	20.0%	\$ 959.99	POWERHEAD	175				
175	Handheld Equipment	3120XP	Husqvarna	965960701		Each	\$ 1,849.99	20.0%	\$ 1,479.99	119cc chainsaw, powerhead only (404)	176				
176	Handheld Equipment	336PR	Husqvarna	966604702		Each	\$ 599.99	20.0%	\$ 479.99	34.6cc bike handle pro brushcutter w/1	177				
177	Handheld Equipment	129CD	Husqvarna	967146701		Each	\$ 179.99	20.0%	\$ 143.99	28cc detachable, curved shaft trimmer, 177	178				
178	Handheld Equipment	1201	Husqvarna	967098102		Each	\$ 259.99	20.0%	\$ 207.99	14", 3/8 pitch, .043 gauge Batt Chainsaw	179				
179	Handheld Equipment	320IB	Husqvarna	967094202		Each	\$ 229.95	20.0%	\$ 183.96	40V Li-Ion handheld blower, 412cfm/1	179				

Non-Core Catalog

Husqvarna Professional Products Inc

Bidding Company Name:

Bidding Company Name: Husqvarna Professional Products Inc					Catalog Name:			Non-Core Catalog			
No.	Product Category	Product Description	Manufacturer	Manufacturer SKU	Vendor SKU	Unit of Measure	Catalog List Price	Bid Discount Percentage	Net Effective Bid Price	Comments	No.
180	Handheld Equipment	115HD55	Husqvarna	967098604		Each	\$ 229.99	20.0%	\$ 183.99	40v double sided battery hedge trimmer	180
181	Handheld Equipment	115H1	Husqvarna	967098702		Each	\$ 229.99	20.0%	\$ 183.99	40V straight shaft battery trimmer kit v	181
182	Handheld Equipment	120i	Husqvarna	967098101		Each	\$ 199.99	20.0%	\$ 159.99	14", 3/8 pitch, 043 gauge, Batt, Chainsaw	182
183	Handheld Equipment	320IB	Husqvarna	967094201		Each	\$ 169.95	20.0%	\$ 135.96	40V Li-Ion handheld blower, 412cfm/1	183
184	Handheld Equipment	115HD55	Husqvarna	967098601		Each	\$ 169.99	20.0%	\$ 135.99	40v double sided battery hedge trimmer	184
185	Handheld Equipment	115PT4	Husqvarna	967867902		Each	\$ 229.99	20.0%	\$ 183.99	40v pole saw, 10" bar, w/ batt & charge	185
186	Handheld Equipment	324L	Husqvarna	967055801		Each	\$ 339.99	20.0%	\$ 271.99	25cc four stroke trimmer, flex drive sha	186
187	Handheld Equipment	322L	Husqvarna	967175201		Each	\$ 249.95	20.0%	\$ 199.96	22.5cc semi professional trimmer, flex c	187
188	Handheld Equipment	1291LK	Husqvarna	967680502		Each	\$ 169.99	20.0%	\$ 135.99	28cc detachable shaft trimmer, LK attac	188
189	Handheld Equipment	128CD	Husqvarna	952711952		Each	\$ 179.99	20.0%	\$ 143.99	28cc detachable, curved shaft trimmer,	189
190	Handheld Equipment	150BT	Husqvarna	965877601		Each	\$ 299.99	20.0%	\$ 239.99	50cc backpack blower, 2.2 hp, 434.cfm	190
191	Handheld Equipment	1291LK	Husqvarna	967680501		Each	\$ 229.99	20.0%	\$ 183.99	28cc detachable shaft trimmer, LK attac	191
192	Handheld Equipment	115H1	Husqvarna	967098701		Each	\$ 229.99	20.0%	\$ 183.99	40V straight shaft battery trimmer w/o	192
193	Handheld Equipment	3508BF	Husqvarna	965877701		Each	\$ 349.99	20.0%	\$ 279.99	50 cc frame throttle b/p blower, 494.cfm	193
194	Handheld Equipment	435e II	Husqvarna	967650801		Each	\$ 279.99	20.0%	\$ 223.99	16", 325 pitch, 050 ga. 40.9cc chainsaw	194
195	Handheld Equipment	435e II	Husqvarna	967650802		Each	\$ 279.99	20.0%	\$ 223.99	16", 325 pitch, 050 ga. 40.9cc chainsaw	195
196	Handheld Equipment	129DJX	Husqvarna	967680601		Each	\$ 279.99	20.0%	\$ 223.99	28cc detach, st. aff. trimmer, LK attachm	196
197	Handheld Equipment	128LD	Husqvarna	952711953		Each	\$ 219.99	20.0%	\$ 175.99	28cc detachable, straight shaft trimmer	197
198	Handheld Equipment	3508BT	Husqvarna	965877502		Each	\$ 349.99	20.0%	\$ 279.99	50 cc tube throttle b/p blower, 494.cfm	198
199	Handheld Equipment	360BT	Husqvarna	967144301		Each	\$ 449.99	20.0%	\$ 359.99	65 cc tube throttle b/p blower, 632.cfm	199
200	Handheld Equipment	440e II	Husqvarna	967650901		Each	\$ 319.99	20.0%	\$ 255.99	18", 325 pitch, 050 ga. 40.9cc chainsaw	200
201	Handheld Equipment	440e II	Husqvarna	967650902		Each	\$ 319.99	20.0%	\$ 255.99	16", 325 pitch, 050 ga. 40.9cc fully assd	201
202	Handheld Equipment	450e II	Husqvarna	967651104		Each	\$ 399.99	20.0%	\$ 319.99	18", 325 pitch, 050 ga. 50.2cc chainsaw	202
203	Handheld Equipment	445e II	Husqvarna	967651103		Each	\$ 359.99	20.0%	\$ 287.99	16", 325 pitch, 050 ga. 50.2cc chainsaw	203
204	Handheld Equipment	445e II	Husqvarna	967651002		Each	\$ 359.99	20.0%	\$ 287.99	16", 325 pitch, 050 ga. 50.2cc chainsaw	204
205	Handheld Equipment	445e II	Husqvarna	967651003		Each	\$ 369.99	20.0%	\$ 295.99	18", 325 pitch, 050 ga. 50.2cc chainsaw	205
206	Handheld Equipment	445e II	Husqvarna	967651004		Each	\$ 379.99	20.0%	\$ 303.99	18", 325 pitch, 050 ga. 50.2cc chainsaw	206
207	Handheld Equipment	450e II	Husqvarna	967651102		Each	\$ 379.99	20.0%	\$ 303.99	18", 325 pitch, 050 ga. 50.2cc chainsaw	207
208	Handheld Equipment	450e II	Husqvarna	967651101		Each	\$ 379.99	20.0%	\$ 303.99	18", 325 pitch, 050 ga. 50.2cc chainsaw	208
209	Handheld Equipment	445e II	Husqvarna	967651005		Each	\$ 459.99	20.0%	\$ 367.99	18", 3/8 pitch, 050 ga. 55.5cc Rancher r	209
210	Handheld Equipment	455 RANCHER	Husqvarna	965030296		Each	\$ 399.99	20.0%	\$ 319.99	20", 325 pitch, 050 ga. 50.2cc saw, assd	210
211	Handheld Equipment	450e Rancher II	Husqvarna	967651201		Each	\$ 469.99	20.0%	\$ 375.99	20", 3/8 pitch, 050 ga. 55.5cc Rancher c	211
212	Handheld Equipment	455 RANCHER	Husqvarna	966037320		Each	\$ 469.99	20.0%	\$ 375.99	20", 3/8 pitch, 050 ga. 55.5cc Rancher c	212
213	Handheld Equipment	455 RANCHER	Husqvarna	965030292		Each	\$ 459.99	20.0%	\$ 367.99	18", 3/8 pitch, 050 ga. 55.5cc Rancher r	213
214	Handheld Equipment	455 RANCHER	Husqvarna	965030298		Each	\$ 469.99	20.0%	\$ 375.99	20", 3/8 pitch, 050 ga. 55.5cc Rancher r	214
215	Handheld Equipment	455 RANCHER	Husqvarna	965030290		Each	\$ 459.99	20.0%	\$ 367.99	18", 3/8 pitch, 058 ga. 55.5cc Rancher r	215
216	Handheld Equipment	450e II	Husqvarna	967651103		Each	\$ 399.99	20.0%	\$ 319.99	20", 325 pitch, 050 ga. 50.2cc chainsaw	216
217	Handheld Equipment	455 RANCHER	Husqvarna	966048594		Each	\$ 469.99	20.0%	\$ 375.99	20", 3/8 pitch, 050 ga. 55.5cc Rancher r	217
218	Handheld Equipment	455 RANCHER	Husqvarna	965030254		Each	\$ 469.99	20.0%	\$ 375.99	20", 3/8 pitch, 058 ga. 55.5cc Rancher r	218
219	Handheld Equipment	460 RANCHER	Husqvarna	966048324		Each	\$ 539.99	20.0%	\$ 431.99	24", 3/8 pitch, 050 ga. 60.3cc Rancher r	219
220	Handheld Equipment	460 RANCHER	Husqvarna	966048334		Each	\$ 539.99	20.0%	\$ 431.99	24", 3/8 pitch, 050 ga. 60.3cc Rancher r	220
221	Handheld Equipment	460 RANCHER	Husqvarna	966048318		Each	\$ 519.99	20.0%	\$ 415.99	18", 3/8 pitch, 050 ga. 60.3cc Rancher r	221
222	Handheld Equipment	115PT4	Husqvarna	967867901		Each	\$ 169.99	20.0%	\$ 135.99	40v pole saw, 10" bar, w/o batt & charg	222
223	Handheld Equipment	460 RANCHER	Husqvarna	966048328		Each	\$ 519.99	20.0%	\$ 415.99	18", 3/8 pitch, 058 ga. 60.3cc Rancher r	223
224	Handheld Equipment	460 RANCHER	Husqvarna	966048320		Each	\$ 529.99	20.0%	\$ 423.99	20", 3/8 pitch, 050 ga. 60.3cc Rancher r	224
225	Handheld Equipment	460 RANCHER	Husqvarna	966048330		Each	\$ 529.99	20.0%	\$ 423.99	20", 3/8 pitch, 058 ga. 60.3cc Rancher r	225
226	Handheld Equipment	125BVX	Husqvarna	952711902		Each	\$ 199.99	20.0%	\$ 159.99	28 cc handheld blower with vac kit, 1.1 hp, 425	226
227	Robotic Mowers	550	Husqvarna	967650205		Each	\$ 3,499.99	10.0%	\$ 3,149.99	Robotic mower, 1.25 acre capacity, Prof	227
228	Robotic Mowers	550H	Husqvarna	967853205		Each	\$ 3,499.99	10.0%	\$ 3,149.99	Robotic mower, 1.25 acre capacity, Prof	228
229	Robotic Mowers	450X	Husqvarna	967853005		Each	\$ 3,499.99	10.0%	\$ 3,149.99	Robotic mower, 1.25 acre capacity, X-lin	229
230	Robotic Mowers	450XH	Husqvarna	967853105		Each	\$ 3,499.99	10.0%	\$ 3,149.99	Robotic mower, 1.25 acre capacity, X-lin	230
231	Robotic Mowers	430X	Husqvarna	967852805		Each	\$ 2,699.99	10.0%	\$ 2,429.99	Robotic mower, 0.8 acre capacity, X-lin	231
232	Robotic Mowers	430XH	Husqvarna	967852905		Each	\$ 2,699.99	10.0%	\$ 2,429.99	Robotic mower, 0.8 acre capacity, X-lin	232
233	Robotic Mowers	315X	Husqvarna	967852705		Each	\$ 1,999.99	10.0%	\$ 1,799.99	Robotic mower, 0.4 acre capacity, X-lin	233
234	Attachments/ Accessories	QC30	Husqvarna	967091403		Each	\$ 99.99	15.0%	\$ 84.99	330W Quick Charge battery charger	234
235	Attachments/ Accessories	BLJ950X	Husqvarna	967093202		Each	\$ 949.99	15.0%	\$ 807.49	40V Li-Ion battery backpack, 31.1Ah, 1	235
236	Attachments/ Accessories	V1600F	Husqvarna	967628504		Each	\$ 229.99	15.0%	\$ 195.49	Voltage Inverter for in field battery cha	236
237	Attachments/ Accessories	V1600F	Husqvarna	967628504		Each	\$ 229.99	15.0%	\$ 195.49	Voltage Inverter for in field battery cha	237
238	Attachments/ Accessories	SR6000-2	Husqvarna	967294401		Each	\$ 319.99	15.0%	\$ 271.99	DX SWEEPER ATTACHMENT (solid sha	238
239	Attachments/ Accessories	SR6000-2	Husqvarna	967294401		Each	\$ 319.99	15.0%	\$ 271.99	DX SWEEPER ATTACHMENT (solid sha	239
240	Attachments/ Accessories	DT600	Husqvarna	967296901		Each	\$ 299.99	15.0%	\$ 254.99	DX Dethatcher Attachment (solid shaft)	240
241	Attachments/ Accessories	DT600	Husqvarna	967296901		Each	\$ 299.99	15.0%	\$ 254.99	DX Dethatcher Attachment (solid shaft)	240

Bidding Company Name:			Husqvarna Professional Products Inc			Catalog Name:			Non-Core Catalog		
No.	Product Category	Product Description	Manufacturer	Manufacturer SKU	Vendor SKU	Unit of Measure	Catalog List Price	Bid Discount Percentage	Net Effective Bid Price	Comments	No.
242	Attachments/ Accessories	BLI300	Husqvarna	967071902		Each	\$ 299.99	15.0%	\$ 254.99	40V Li-Ion professional battery, 9Ah, 3.2	241
243	Attachments/ Accessories	BR600	Husqvarna	967296701		Each	\$ 279.99	15.0%	\$ 237.99	DX Bristle Brush Attachment (solid shaft)	242
244	Attachments/ Accessories	BR600	Husqvarna	967296701		Each	\$ 279.99	15.0%	\$ 237.99	DX Bristle Brush Attachment (solid shaft)	243
245	Attachments/ Accessories	CA230	Husqvarna	967091702		Each	\$ 149.99	15.0%	\$ 127.49	40V Li-Ion homeowner battery, 4.0Ah, 1.4	244
246	Attachments/ Accessories	CA230	Husqvarna	967294201		Each	\$ 199.99	15.0%	\$ 169.99	LK CULTIVATOR ATTACHMENT (solid shaft)	245
247	Attachments/ Accessories	CA230	Husqvarna	967294201		Each	\$ 199.99	15.0%	\$ 169.99	LK CULTIVATOR ATTACHMENT (solid shaft)	246
248	Attachments/ Accessories	BA1200	Husqvarna	967091902		Each	\$ 199.99	15.0%	\$ 169.99	40V Li-Ion professional battery, 5Ah, 1.8	247
249	Attachments/ Accessories	BA101	Husqvarna	967286401		Each	\$ 129.99	15.0%	\$ 110.49	LK Blower Attachment, 530cfm, 148mp	248
250	Attachments/ Accessories	BA101	Husqvarna	967286401		Each	\$ 129.99	15.0%	\$ 110.49	LK Blower Attachment, 530cfm, 148mp	249
251	Attachments/ Accessories	BLI100	Husqvarna	967091802		Each	\$ 139.99	15.0%	\$ 118.99	40V Li-Ion professional battery, 2.5Ah, 1.2	250
252	Attachments/ Accessories	HA110	Husqvarna	590776704		Each	\$ 259.99	15.0%	\$ 220.99	Connector kit, including belt. Blt carrier	251
253	Attachments/ Accessories	HA110	Husqvarna	537196605		Each	\$ 259.99	15.0%	\$ 220.99	DX HEDGE TRIMMER ATTACHMENT 4"	252
254	Attachments/ Accessories	EX780	Husqvarna	967297101		Each	\$ 69.99	15.0%	\$ 59.49	DX Extension Attachment (solid shaft)	253
255	Attachments/ Accessories	EX780	Husqvarna	967297101		Each	\$ 69.99	15.0%	\$ 59.49	DX Extension Attachment (solid shaft)	254
256	Attachments/ Accessories	HA850	Husqvarna	537196606		Each	\$ 279.99	15.0%	\$ 237.99	DX HEDGE TRIMMER ATTACHMENT 3.3"	255
257	Attachments/ Accessories	HA850	Husqvarna	537196606		Each	\$ 279.99	15.0%	\$ 237.99	DX HEDGE TRIMMER ATTACHMENT 3.3"	256
258	Attachments/ Accessories	QC80F	Husqvarna	967628401		Each	\$ 59.99	15.0%	\$ 50.99	Battery charger for in vehicle charging	257
259	Attachments/ Accessories	QC80F	Husqvarna	967628401		Each	\$ 59.99	15.0%	\$ 50.99	Battery charger for in vehicle charging	258
260	Attachments/ Accessories	BCA850	Husqvarna	967185901		Each	\$ 99.99	15.0%	\$ 84.99	LK Brushcutter Attachment (solid shaft)	259
261	Attachments/ Accessories	PA1100	Husqvarna	537183325		Each	\$ 209.99	15.0%	\$ 178.49	DX POLE SAW ATTACHMENT 43" BOON	260
262	Attachments/ Accessories	PA1100	Husqvarna	537183325		Each	\$ 219.99	15.0%	\$ 186.99	DX POLE SAW ATTACHMENT 43" BOON	261
263	Attachments/ Accessories	Top Cover Gray (Fits 315X)	Husqvarna	590876910		Each	\$ 39.99	15.0%	\$ 33.99	Automower Accessories	262
264	Attachments/ Accessories	Top Cover White (Fits 315X)	Husqvarna	590876910		Each	\$ 39.99	15.0%	\$ 33.99	Automower Accessories	263
265	Attachments/ Accessories	AUTOMOWER CONNECT 3G/3G	Husqvarna	590876902		Each	\$ 79.99	15.0%	\$ 67.99	Automower Accessories	264
266	Attachments/ Accessories	(FITS 300-400-500 SERIES)	Husqvarna	586662405		Each	\$ 249.99	15.0%	\$ 212.49	Automower Accessories	265
267	Attachments/ Accessories	Signal Booster (Fits Z20AC, Z30ACX)	Husqvarna	522425801		Each	\$ 179.99	15.0%	\$ 152.99	Automower Accessories	266
268	Attachments/ Accessories	4 Gallon Backpack Sprayer	Husqvarna	596765901		Each	\$ 109.99	15.0%	\$ 93.49	Sprayer	267
269	Attachments/ Accessories	Twin Bagger, 42" Stamped Tractor	Husqvarna	960730004		Each	\$ 329.00	15.0%	\$ 279.65	Tractor Baggers	268
270	Attachments/ Accessories	Twin Bagger, 42" Stamped Tractor	Husqvarna	960730038		Each	\$ 449.00	15.0%	\$ 381.65	Tractor Baggers	269
271	Attachments/ Accessories	Twin Bagger, 42" Stamped Tractor	Husqvarna	960730024		Each	\$ 329.00	15.0%	\$ 279.65	Tractor Baggers	270
272	Attachments/ Accessories	Triple Bagger, 46"/48" Stamped Tractor	Husqvarna	960730037		Each	\$ 449.00	15.0%	\$ 381.65	Tractor Baggers	271
273	Attachments/ Accessories	Triple Bagger, 48" Stamped, CT frame	Husqvarna	960730025		Each	\$ 449.00	15.0%	\$ 381.65	Tractor Baggers	272
274	Attachments/ Accessories	Triple Bagger, 54" Stamped Tractor	Husqvarna	960730026		Each	\$ 349.00	15.0%	\$ 296.65	Tractor Baggers	273
275	Attachments/ Accessories	Twin Bagger w/ Blower 42/ 48" Estate Fab tractor	Husqvarna	966805002		Each	\$ 899.00	15.0%	\$ 764.15	Tractor Baggers	274
276	Attachments/ Accessories	Twin Bagger w/ Blower 52" Estate Fab tractor	Husqvarna	966805003		Each	\$ 899.00	15.0%	\$ 764.15	Tractor Baggers	275
277	Attachments/ Accessories	Twin Bagger, 42" ClearCut Tractor	Husqvarna	587412701		Each	\$ 399.00	15.0%	\$ 339.15	Tractor Baggers	276
278	Attachments/ Accessories	Triple Bagger, 48" ClearCut Tractor	Husqvarna	582559601		Each	\$ 449.00	15.0%	\$ 381.65	Tractor Baggers	277
279	Attachments/ Accessories	Triple Bagger, 54" ClearCut Tractor	Husqvarna	591111301		Each	\$ 449.00	15.0%	\$ 381.65	Tractor Baggers	278
280	Attachments/ Accessories	Twin Bagger, 42" Stamped Zero Turn Z142	Husqvarna	597279801		Each	\$ 349.00	15.0%	\$ 296.65	Zero Turn Baggers	279
281	Attachments/ Accessories	Twin Bagger, 46" Stamped Zero Turn Z200 RZ	Husqvarna	587960401		Each	\$ 499.00	15.0%	\$ 424.15	Zero Turn Baggers	280
282	Attachments/ Accessories	Triple Bagger, 54" Stamped Zero Z200 RZ54	Husqvarna	592620801		Each	\$ 549.00	15.0%	\$ 466.65	Zero Turn Baggers	281
283	Attachments/ Accessories	Triple Bagger, 54" Stamped Zero MZ5424	Husqvarna	966721201		Each	\$ 549.00	15.0%	\$ 466.65	Zero Turn Baggers	282
284	Attachments/ Accessories	Triple Bagger w/blower 48" Estate Fab, Zero Turn Z200/RZ	Husqvarna	587960201		Each	\$ 1,099.00	15.0%	\$ 934.15	Zero Turn Baggers	283
285	Attachments/ Accessories	Triple Bagger w/ Blower 52" MZ zero turn	Husqvarna	966793001		Each	\$ 1,099.00	15.0%	\$ 934.15	Zero Turn Baggers	284
286	Attachments/ Accessories	Triple Bagger w/Blower 61" MZ Zero Turn	Husqvarna	966793101		Each	\$ 1,099.00	15.0%	\$ 934.15	Zero Turn Baggers	285
287	Attachments/ Accessories	Twin Bagger, 42" ClearCut Zero Turn	Husqvarna	587412401		Each	\$ 499.00	15.0%	\$ 424.15	Zero Turn Baggers	286
288	Attachments/ Accessories	Twin Bagger, 42" ClearCut 42" Z200	Husqvarna	587412401		Each	\$ 499.00	15.0%	\$ 424.15	Zero Turn Baggers	287
289	Attachments/ Accessories	Triple Bagger, 48" ClearCut Zero Turn MZ48	Husqvarna	582559801		Each	\$ 499.00	15.0%	\$ 424.15	Zero Turn Baggers	288
290	Attachments/ Accessories	Triple Bagger, 48" ClearCut, Zero Turn Z200	Husqvarna	582559701		Each	\$ 499.00	15.0%	\$ 424.15	Zero Turn Baggers	289
291	Attachments/ Accessories	Triple Bagger, 54" ClearCut Z200	Husqvarna	591111401		Each	\$ 499.00	15.0%	\$ 424.15	Zero Turn Baggers	290
292	Attachments/ Accessories	Triple Bagger, 54" ClearCut MZ54	Husqvarna	591111501		Each	\$ 499.00	15.0%	\$ 424.15	Zero Turn Baggers	291
293	Attachments/ Accessories	Z400 60/54 Commercial OCDC and Z500 60/54	Husqvarna	966488701		Each	\$ 299.00	15.0%	\$ 254.15	Zero Turn Baggers	292
294	Attachments/ Accessories	Z400 60/54 Collection: 3 Bin / 9 bushels	Husqvarna	598390201		Each	\$ 1,899.00	15.0%	\$ 1,614.15	Zero Turn Baggers	293
295	Attachments/ Accessories	Z400 48 Clear Cut Collection: 3 Bin / 9 bushels	Husqvarna	598532802		Each	\$ 1,099.00	15.0%	\$ 934.15	Zero Turn Baggers	294
296	Attachments/ Accessories	Z400 54 Clear Cut Collection	Husqvarna	598532801		Each	\$ 1,099.00	15.0%	\$ 934.15	Zero Turn Baggers	295
297	Attachments/ Accessories	Z560X / Z560 / Z554X / Z554 / PZT48 / PZT54 / PZT60 Collection: 9 Bushel	Husqvarna	967322401		Each	\$ 2,399.00	15.0%	\$ 2,039.15	Zero Turn Baggers	296
298	Attachments/ Accessories	Z560X / PZ60 / PZ54 Collection: 13 Bushel	Husqvarna	967322601		Each	\$ 2,499.00	15.0%	\$ 2,124.15	Zero Turn Baggers	297

Bidding Company Name:			Husqvarna Professional Products Inc			Catalog Name:			Non-Core Catalog		
No.	Product Category	Product Description	Manufacturer	Manufacturer SKU	Vendor SKU	Unit of Measure	Catalog List Price	Bid Discount Percentage	Net Effective Bid Price	Comments	No.
299	Attachments/ Accessories	Z560X / Z560 / Z554X / Z554 / PZ54 / PZ60 Collection: 11 Bushel	Husqvarna	967322701		Each	\$ 3,199.00	15.0%	\$ 2,719.15	Zero Turn Baggers	298
300	Attachments/ Accessories	M-ZT 52 Collection	Husqvarna	966793002		Each	\$ 1,399.00	15.0%	\$ 1,189.15	Zero Turn Baggers	299
301	Attachments/ Accessories	M-ZT 61 Collection	Husqvarna	966793003		Each	\$ 1,399.00	15.0%	\$ 1,189.15	Zero Turn Baggers	300
302	Attachments/ Accessories	P-ZT 48, 54, 60 P-ZT Collection : 8 bushel	Husqvarna	967322501		Each	\$ 2,799.00	15.0%	\$ 2,379.15	Zero Turn Baggers	301
303	Attachments/ Accessories	V548 / V554 ODC	Husqvarna	592912101		Each	\$ 199.00	15.0%	\$ 169.15	Zero Turn Baggers	302
304	Attachments/ Accessories	V548 / V554 Collection	Husqvarna	592912001		Each	\$ 329.00	15.0%	\$ 279.65	Zero Turn Baggers	303
305	Attachments/ Accessories	Mulch Kit, 42" Stamped	Husqvarna	531309641		Each	\$ 49.99	15.0%	\$ 42.49	Mulch Kits	304
306	Attachments/ Accessories	Mulch Kit, 42" Stamped	Husqvarna	576682701		Each	\$ 49.99	15.0%	\$ 42.49	Mulch Kits	305
307	Attachments/ Accessories	Mulch Kit 46" Stamped	Husqvarna	525405001		Each	\$ 54.99	15.0%	\$ 46.74	Mulch Kits	306
308	Attachments/ Accessories	Mulch Kit 46" Stamped	Husqvarna	531309580		Each	\$ 49.99	15.0%	\$ 42.49	Mulch Kits	307
309	Attachments/ Accessories	Mulch Kit 48" Stamped	Husqvarna	531309642		Each	\$ 54.99	15.0%	\$ 46.74	Mulch Kits	308
310	Attachments/ Accessories	Mulch Kit 54" Stamped (O P P)	Husqvarna	531309643		Each	\$ 64.99	15.0%	\$ 55.24	Mulch Kits	309
311	Attachments/ Accessories	Mulch Kit 54" Stamped (O P P)	Husqvarna	531309626		Each	\$ 69.99	15.0%	\$ 59.49	Mulch Kits	310
312	Attachments/ Accessories	Mulch Kit, 42" ClearCut™	Husqvarna	587412301		Each	\$ 54.99	15.0%	\$ 46.74	Mulch Kits	311
313	Attachments/ Accessories	Mulch Kit, 48" ClearCut™ (Z200 and Tractor)	Husqvarna	582559901		Each	\$ 69.99	15.0%	\$ 59.49	Mulch Kits	312
314	Attachments/ Accessories	Mulch Kit, 54" ClearCut™	Husqvarna	591102101		Each	\$ 59.99	15.0%	\$ 50.99	Mulch Kits	313
315	Attachments/ Accessories	Mulch Kit, 42" Estate Fab deck (3 Blid)	Husqvarna	966412901		Each	\$ 139.99	15.0%	\$ 118.99	Mulch Kits	314
316	Attachments/ Accessories	Mulch Kit, 48" Estate Fab deck	Husqvarna	965894003		Each	\$ 179.99	15.0%	\$ 152.99	Mulch Kits	315
317	Attachments/ Accessories	Mulch Kit 52" Estate Fab Deck Tractor	Husqvarna	966515201		Each	\$ 169.99	15.0%	\$ 144.49	Mulch Kits	316
318	Attachments/ Accessories	Mulch Kit 54" Clear Cut Mulch Kit: MZ54	Husqvarna	591102101		Each	\$ 59.99	15.0%	\$ 50.99	Mulch Kits	317
319	Attachments/ Accessories	Mulch Kit 48" Clear Cut Mulch Kit: MZ48	Husqvarna	582560001		Each	\$ 64.99	15.0%	\$ 55.24	Mulch Kits	318
320	Attachments/ Accessories	Mulch Kit 54" Z400/Z500	Husqvarna	598390501		Each	\$ 279.00	15.0%	\$ 237.15	Mulch Kits	319
321	Attachments/ Accessories	Mulch Kit 60" Z400/Z500	Husqvarna	598390601		Each	\$ 279.00	15.0%	\$ 237.15	Mulch Kits	320
322	Attachments/ Accessories	Mulch Kit 54" Z554 / Z554X	Husqvarna	966050401		Each	\$ 279.00	15.0%	\$ 237.15	Mulch Kits	321
323	Attachments/ Accessories	Mulch Kit 60" Z560X / Z560	Husqvarna	966444701		Each	\$ 279.00	15.0%	\$ 237.15	Mulch Kits	322
324	Attachments/ Accessories	Mulch Kit 72" Z572X	Husqvarna	966051701		Each	\$ 299.00	15.0%	\$ 254.15	Mulch Kits	323
325	Attachments/ Accessories	Mulch Kit 52" : M-ZT 52	Husqvarna	965894001		Each	\$ 169.99	15.0%	\$ 144.49	Mulch Kits	324
326	Attachments/ Accessories	Mulch Kit 61" : M-ZT 61	Husqvarna	965894002		Each	\$ 169.99	15.0%	\$ 144.49	Mulch Kits	325
327	Attachments/ Accessories	Mulch Kit 48" :V500	Husqvarna	592810501		Each	\$ 149.99	15.0%	\$ 127.49	Mulch Kits	326
328	Attachments/ Accessories	Mulch Kit 54" :V500	Husqvarna	592809501		Each	\$ 159.99	15.0%	\$ 135.99	Mulch Kits	327
329	Attachments/ Accessories	PZ / P-ZT / Z560X / Z560 / Z554X / Z555 54" / 60" Drive Kit	Husqvarna	966407201		Each	\$ 149.99	15.0%	\$ 127.49	Drive Kits / Grass Blower Assembly (Zero Turn Mowers)	
330	Attachments/ Accessories	PZ-T / Z548 / CZT148X 48" (Serial Numbers 100112 and higher)	Husqvarna	966407102		Each	\$ 159.99	15.0%	\$ 135.99	Drive Kits / Grass Blower Assembly (Zero Turn Mowers)	
331	Attachments/ Accessories	Z400 60" Drive Kit	Husqvarna	598390301		Each	\$ 149.99	15.0%	\$ 127.49	Drive Kits / Grass Blower Assembly (Zero Turn Mowers)	
332	Attachments/ Accessories	Z400 54" Drive Kit	Husqvarna	598390401		Each	\$ 149.99	15.0%	\$ 127.49	Drive Kits / Grass Blower Assembly (Zero Turn Mowers)	
333	Attachments/ Accessories	PZ / P-ZT Grass Blower Assembly: 54" / 60"	Husqvarna	587251201		Each	\$ 899.00	15.0%	\$ 764.15	Drive Kits / Grass Blower Assembly (Zero Turn Mowers)	
334	Attachments/ Accessories	MZ / MZ-T Grass Blower Assembly: 54" / 60"	Husqvarna	966795702		Each	\$ 749.00	15.0%	\$ 636.65	Drive Kits / Grass Blower Assembly (Zero Turn Mowers)	
335	Attachments/ Accessories	Arm Rest Kit : RZ series	Husqvarna	582384601		Each	\$ 49.99	15.0%	\$ 42.49	Arm Rests, Light Kits, Seats, Hitch Kits (Zero Turn Mowers)	
336	Attachments/ Accessories	Battery Charger	Husqvarna	585445101		Each	\$ 49.99	15.0%	\$ 42.49	Arm Rests, Light Kits, Seats, Hitch Kits (Zero Turn Mowers)	
337	Attachments/ Accessories	Light Kit	Husqvarna	539132388		Each	\$ 139.99	15.0%	\$ 118.99	Arm Rests, Light Kits, Seats, Hitch Kits (Zero Turn Mowers)	
338	Attachments/ Accessories	Light Kit	Husqvarna	539131805		Each	\$ 99.99	15.0%	\$ 84.99	Arm Rests, Light Kits, Seats, Hitch Kits (Zero Turn Mowers)	
339	Attachments/ Accessories	Light Kit (ROPS)	Husqvarna	576809001		Each	\$ 139.99	15.0%	\$ 118.99	Arm Rests, Light Kits, Seats, Hitch Kits (Zero Turn Mowers)	
340	Attachments/ Accessories	Premium Suspension Seat (Seats Inc)	Husqvarna	576368601		Each	\$ 549.00	15.0%	\$ 466.65	Arm Rests, Light Kits, Seats, Hitch Kits (Zero Turn Mowers)	
341	Attachments/ Accessories	Roll Over Protection	Husqvarna	575274801		Each	\$ 449.00	15.0%	\$ 381.65	Arm Rests, Light Kits, Seats, Hitch Kits (Zero Turn Mowers)	
342	Attachments/ Accessories	Hitch Kit - RZ / Z200	Husqvarna	587481201		Each	\$ 24.99	15.0%	\$ 21.24	Arm Rests, Light Kits, Seats, Hitch Kits (Zero Turn Mowers)	
343	Attachments/ Accessories	Hitch Kit : MZ series	Husqvarna	588971201		Each	\$ 24.99	15.0%	\$ 21.24	Arm Rests, Light Kits, Seats, Hitch Kits (Zero Turn Mowers)	
344	Attachments/ Accessories	Tractor Seat Cover	Husqvarna	588208702		Each	\$ 84.00	15.0%	\$ 71.40	Covers and Shades	
345	Attachments/ Accessories	Tractor Seat Cover	Husqvarna	588208701		Each	\$ 39.99	15.0%	\$ 33.99	Covers and Shades	344
346	Attachments/ Accessories	Tractor Seat Cover w/ Armrest Holes	Husqvarna	588208703		Each	\$ 39.99	15.0%	\$ 33.99	Covers and Shades	345
347	Attachments/ Accessories	Tractor Sun Shade	Husqvarna	531308322		Each	\$ 149.99	15.0%	\$ 127.49	Covers and Shades	346
348	Attachments/ Accessories	Zero-Turn Mower Cover, up to 54" deck	Husqvarna	582846201		Each	\$ 84.00	15.0%	\$ 71.40	Covers and Shades	347
349	Attachments/ Accessories	Zero-Turn Sun Shade	Husqvarna	596542901		Each	\$ 149.99	15.0%	\$ 127.49	Covers and Shades	348
350	Attachments/ Accessories	48" Snow Blade	Husqvarna	588181302		Each	\$ 399.00	15.0%	\$ 339.15	Snow Blades	
351	Attachments/ Accessories	50" 2-Stage Snow Thrower with Electric Lift	Husqvarna	967343902		Each	\$ 2,199.00	15.0%	\$ 1,869.15	2-Stage Snow Thrower Attachments	
352	Attachments/ Accessories	42" 2-Stage Snow Thrower (Electric Lift)	Husqvarna	587293701		Each	\$ 1,899.00	15.0%	\$ 1,614.15	2-Stage Snow Thrower Attachments	351
353	Attachments/ Accessories	42" 2-Stage Snow Thrower (Manual Lift)	Husqvarna	967343901		Each	\$ 1,599.00	15.0%	\$ 1,359.15	2-Stage Snow Thrower Attachments	352
354	Attachments/ Accessories	Weight/Bracket and weight (TA321)	Husqvarna	505549201		Each	\$ 149.99	15.0%	\$ 127.49	Wheel Weights	
355	Attachments/ Accessories	Wheel Weights One pair (62 lbs.)	Husqvarna	954050501		Each	\$ 89.99	15.0%	\$ 76.49	Wheel Weights	354
356	Attachments/ Accessories	Wheel Weights One individual weight (50 lbs. each)	Husqvarna	954040102		Each	\$ 69.99	15.0%	\$ 59.49	Wheel Weights	355
357	Attachments/ Accessories	18" x 9.5" x 8"	Husqvarna	954050202		Each	\$ 99.99	15.0%	\$ 84.99	Tire Chains	

Non-Core Catalog

Husqvarna Professional Products Inc

Bidding Company Name:

Bidding Company Name:				Husqvarna Professional Products Inc				Catalog Name:				Non-Core Catalog			
No.	Product Category	Product Description	Manufacturer	Manufacturer SKU	Vendor SKU	Unit of Measure	Catalog List Price	Bid Discount Percentage	Net Effective Bid Price	Comments	No.				
358	Attachments/ Accessories	20" x 8" x 8"	Husqvarna	954050203		Each	\$ 99.99	15.0%	\$ 84.99	Tire Chains	357				
359	Attachments/ Accessories	20" x 10" x 8"	Husqvarna	954050201		Each	\$ 99.99	15.0%	\$ 84.99	Tire Chains	358				
360	Attachments/ Accessories	22" x 9.5" x 12"	Husqvarna	531307186		Each	\$ 99.99	15.0%	\$ 84.99	Tire Chains	359				
361	Attachments/ Accessories	23" x 10.5" x 12"	Husqvarna	954040111		Each	\$ 99.99	15.0%	\$ 84.99	Tire Chains	360				
362	Attachments/ Accessories	Tractor Snow Cab (4-sided)	Husqvarna	594008501		Each	\$ 329.00	15.0%	\$ 279.65	Tractor Snow Cab	361				
363	Attachments/ Accessories	2,000 lb. Loading Ramps	Husqvarna	585445501		Each	\$ 219.00	15.0%	\$ 186.15	Loading Ramps	363				
364	Attachments/ Accessories	Tractor Lift	Husqvarna	585445401		Each	\$ 219.00	15.0%	\$ 186.15	Tractor Lift	363				
365	Attachments/ Accessories	Tractor Bumper Kit	Husqvarna	531307007		Each	\$ 54.99	15.0%	\$ 46.74	Tractor Bumper and Brush Guard	365				
366	Attachments/ Accessories	LS Brush Guard	Husqvarna	505568813		Each	\$ 89.99	15.0%	\$ 76.49	Tractor Bumper and Brush Guard	366				
367	Specialty Turf Equipment	SG13	Husqvarna	970445401		Each	\$ 4,699.95	20.0%	\$ 3,759.96	Stump Grinder Honda GX390 11.7 HP	367				
368	Specialty Turf Equipment	TA48	Husqvarna	968999236		Each	\$ 1,849.95	20.0%	\$ 1,479.96	48" Trip Air Towable Aerator	367				
369	Specialty Turf Equipment	DT18	Husqvarna	966019501		Each	\$ 1,524.95	20.0%	\$ 1,219.96	18" Power Rake, Flail Briggs & Stratton	368				
370	Specialty Turf Equipment	SC18	Husqvarna	968999509		Each	\$ 4,899.95	20.0%	\$ 3,919.96	18" Sod Cutter Honda GX160 4.8 HP	369				
371	Specialty Turf Equipment	DT22	Husqvarna	966067101		Each	\$ 1,624.95	20.0%	\$ 1,299.96	22" Power Rake, Flail Briggs & Stratton	370				
372	Specialty Turf Equipment	AR25	Husqvarna	968982105		Each	\$ 3,899.95	20.0%	\$ 3,119.96	25.5" Aerator Honda GX120 3.5 HP	371				
373	Specialty Turf Equipment	DT22H	Husqvarna	966068501		Each	\$ 1,849.95	20.0%	\$ 1,479.96	22" Power Rake, Flail Honda GX160 4.8 HP	372				
374	Specialty Turf Equipment	SD22	Husqvarna	966067801		Each	\$ 1,624.95	20.0%	\$ 1,299.96	22" Power Rake, NO REEL Honda GX160 4.8 HP	373				
375	Specialty Turf Equipment	AR19H	Husqvarna	968982102		Each	\$ 1,949.95	20.0%	\$ 1,559.96	22" Seeder Briggs & Stratton 900 Series	374				
376	Specialty Turf Equipment	BE650	Husqvarna	967657901		Each	\$ 3,299.95	20.0%	\$ 2,639.96	19" Aerator Honda GX120 3.5 HP	375				
377	Specialty Turf Equipment	SD22H	Husqvarna	966068701		Each	\$ 3,499.95	20.0%	\$ 2,799.96	BE650 Bed Edger Honda GX200 5.5 HP	376				
378	Specialty Turf Equipment	AR19	Husqvarna	968999277		Each	\$ 2,174.95	20.0%	\$ 1,739.96	22" Seeder Honda GX160 4.8 HP	377				
379	Snow Equipment	ST124	Husqvarna	970449301		Each	\$ 3,099.95	20.0%	\$ 2,479.96	19" Aerator, Briggs & Stratton 900 Series	378				
380	Snow Equipment	ST 327	Husqvarna	961930123		Each	\$ 699.99	20.0%	\$ 559.99	24" / Dual Stage / 212cc	379				
381						Each	\$ 1,399.99	20.0%	\$ 1,119.99	27" / Power Steering / Dual Stage / Heated	380				
382											381				
383											382				
384											383				
385											384				
386											385				
387											386				
388											387				
389											388				
390											389				
391											390				
392											391				
393											392				
394											393				
395											394				
396											395				
397											396				
398											397				
399											398				
400											399				
401											400				
402											401				
403											402				
404											403				
405											404				
406											405				
407											406				
408											407				
409											408				
410											409				
411											410				
412											411				
413											412				
414											413				
415											414				
416											415				
417											416				
418											417				
											418				



Association of Educational
PURCHASING AGENCIES

Part F.3 – Services Price Schedule

AEPA #020-E Lawn & Groundskeeping Equipment

Bidding Company Name:

Husqvarna Professional Products Inc.

NOTE: If your company provides any of the non-mandatory services listed below, please complete the price schedule.

Part F.3 is an OPTIONAL FORM

Description	Regular Price or Rates	Discounted Price or Rates	Per Diem Charges (if any)	Mileage Charges (if any)	*Additional Discount on Large Projects: Y/N

Description	Regular Price or Rates	Discounted Price or Rates	Per Diem Charges (if any)	Mileage Charges (if any)	*Additional Discount on Large Projects: Y/N
Installation of 315X Automower	\$ 550.00	No Discount			
Installation of 430X/430XH Automower	\$ 675.00	No Discount			
Installation of 450X/450XH Automower	\$ 1,050.00	No Discount			
Installation of 550/550H Automower	\$ 1,050.00	No Discount			

Description	Regular Price or Rates	Discounted Price or Rates	Per Diem Charges (if any)	Mileage Charges (if any)	*Additional Discount on Large Projects: Y/N

Description	Regular Price or Rates	Discounted Price or Rates	Per Diem Charges (if any)	Mileage Charges (if any)	*Additional Discount on Large Projects: Y/N

Description	Regular Price or Rates	Discounted Price or Rates	Per Diem Charges (if any)	Mileage Charges (if any)	*Additional Discount on Large Projects: Y/N

Exhibit B – Marketing Plan, Husqvarna Professional Products

Goal: Collaborate with the Association of Educational Purchasing Agencies to market and promote usage of the contract within territories/states who have elected to participate in the agreement.

In order to train our extensive salesforce (including dealers who represent Husqvarna), we utilize several different media to communicate new campaigns, promotions, and contracts secured. Below is a snapshot of the different medias used, with a description of how these would benefit usage of the AEPA contract.

Training Strategies:

1. Dealer-Exclusive Online Portal – Husqvarna Dealers have access to an exclusive online portal which allows Husqvarna to provide updates on promotions and specific marketing materials. Within this portal, Husqvarna can upload Advertising Support Materials created specifically for Husqvarna’s partnership with AEPA. These materials will help Husqvarna’s customer facing dealers promote usage of the contract in their daily interactions with end-users.
2. Quarterly Mailed Newsletters – Husqvarna creates and sends a Quarterly Newsletter to all of our authorized dealers. Upon award of the AEPA contract, our intent would be to create a piece within the newsletter to explain the new partnership and promote usage of the contract with all participating members.
3. Regularly Scheduled Conference/Sales Calls – Husqvarna hosts conference calls regularly with our authorized dealer network. Utilizing this platform, Husqvarna could provide updates to the group as a whole once we have been awarded as an AEPA Vendor Partner.
4. Weekly Emails – Husqvarna regularly sends email communications to our dealer network to provide updates on programs and new activities within the organization.

In order to communicate directly with participating members and end users, Husqvarna anticipates utilizing several mediums to promote usage of the AEPA Contract.

Marketing Strategies:

1. Direct Mailers/Emails – Husqvarna will create Husqvarna and AEPA branded mailers/emails to be distributed directly to end users within the Participating Member states. From a high level, these communications will be intended to announce the new partnership between AEPA and Husqvarna, as well as provide details on where to get additional information to use the contract. Husqvarna has both in-house and contract graphic designers that produce content, advertisements, graphic materials, etc.
2. Government Webpage – Upon becoming a AEPA Vendor Partner, Husqvarna will begin to develop a webpage to be included on Husqvarna.com. The webpage will display the contract Husqvarna has been awarded, provide categories of equipment applicable to the contract, and provide additional details on how to participate in using the contract.

3. Outbound Calling – After becoming an AEPA Vendor Partner, Husqvarna intends to utilize our inside sales team to begin outbound calling to agencies within the AEPA participating states. The purpose of these calls will be to announce the partnership between Husqvarna and AEPA, understand agency's needs, and promote usage of the AEPA contract to fulfill these needs.
4. Attendance Trade Shows and Conferences – If Husqvarna is selected to be an AEPA Vendor Partner, we anticipate participating in the following meetings, conferences, and exhibitions. The goal of attendance will be to promote the Husqvarna and AEPA brands, and encourage usage of the contract for upcoming grounds maintenance equipment purchases.
 - a. AEPA Member and Vendor Meetings
 - b. Association of School Business Officials International Annual Conference & Expo
 - c. NIGP Forum & Products Exposition
 - d. National Association of Educational Procurement Annual Meeting

HUSQVARNA LIMITED WARRANTY

We warrant our product are free from defects in material or workmanship under normal use and maintenance. We will, at our option, repair or replace any defective product or defective part covered by the Limited Warranty, free of charge at any authorized Servicing Dealer/Center using OEM replacement parts, subject to the limitations and exclusions described below.

Limited Warranty period. We will warrant the product to the original purchaser from the date of purchase for the applicable period of time shown on the chart below.

What is NOT covered. This Limited Warranty does not cover:

(a) Normal wear parts (parts and items that normally wear out with use). including without limitation spark plugs, bulbs, filters, lubricants, starter cords, belts, blades, and blade adapters are covered if they are defective. However, if such parts need replacement simply because they have worn out. then such replacement is not covered by this warranty, nor is damage due to normal wear, such as abrasion to mower decks, tires punctured by an external source, natural discoloration of materials, or dulling or damage to blades due to contact with abrasives, rocks, rods, or other foreign objects.

(b) Engine or component damage caused by mismatched pitch or gauge of bar, chain or sprockets, or by improper chain filing, maintenance procedures, chain adjustments, or cutting habits

(c) Emissions control equipment and components to the extent regulated by the U.S. Environmental Protection Agency or similar government agencies. These are covered by a separate emission control warranty contained in the operator's manual packet.

(d) Depending on the product, there is either NO WARRANTY or a reduced warranty if the product is used for commercial, nonresidential, or rental purposes and, in such circumstances, this Limited Warranty is offered instead of and replaces any warranty regime provided by law. Please refer to the chart below.

(e) Damage, malfunctions or failures resulting from abuse or neglect of the product related to or including any of the following:

- 1. Failure to provide or perform required maintenance services as prescribed in the owner's manual.**
- 2. Abuse, misuse, neglect, modifications, alterations, normal wear, improper servicing, use of unauthorized attachments, lack of lubrication or engine failure, due to the use of oils that do not meet Engine manufacturer's specifications.**
- 3. Use of gasohol (fuel containing ethanol). containing methanol (fuel containing wood alcohol). Ethanol fuel E15 or E85 is NOT approved for use in Husqvarna products. Using E15 or E85 fuel will cause major engine damage which is NOT covered by this Husqvarna warranty. Note: Gasohol (fuel containing ethanol), which contains a maximum 10% ethanol (grain alcohol) is approved. The prescribed mixing ratio of gasoline to oil is 50:1 and is listed on the Husqvarna oil label and covered in your owner's manual.**
- 4. Damage caused by old fuel, stale fuel, or bad fuel.**

5. **Use of ether or any starting fluids.**
6. **Pressure cleaning or steam cleaning the product.**
7. **Use of spark plugs other than those meeting emission performance requirements listed in the owner's manual.**
8. **Tampering with engine speed governor or emission components, or running engines above specified and recommended engine speeds as in your owner's manual.**
9. **Operation of the unit with improperly installed, removed, or modified cutting shields, guards or safety devices.**
10. **Any removed, damaged air filter, excessive dirt, abrasives, salt water, moisture, corrosion, rust, varnish, stale fuel, or any adverse reaction due to incorrect storage procedures ...**

(f) Damage or failures due to improper set up, pre-delivery service or repair service by anyone other than an authorized servicing dealer during the warranty period.

(g) Damage caused by use of gasoline containing more than 10% (E10) ethanol content (e.g. E15, E25, E30, E50, E85), use of ether or similar starting fluids, or stale fuel.

(h) Damage caused by dirt contaminated grease or oil, use of incorrect type of grease or oils, failure to comply with regular greasing intervals, water or moisture damage, and, or improper storage

(i) Sprayers pumping or spraying caustic or flammable materials, lack of broken strainers, or continued use of product after initial operational problem or failure occurs.

O) First-sale units with a date of manufacture greater than 12 months will NOT carry a battery warranty.

(k) Riding mowers, Zero Turn Mowers, and Walk Mowers that have batteries for starting purposes, the battery is not covered under warranty if the battery is discharged.

(l) Scratch & Dent purchases and prior model year sales including discounted units (from Husqvarna directly or transferred from Dealer to Dealer) there is no battery warranty provided on scratch & dent units.

Your Responsibilities. To preserve your rights under this Limited Warranty, you must exercise reasonable care and use of the product, including following the preventive maintenance, storage, and fuel and oil usages as prescribed in the operator's manual. Any adjustment (e.g. to the throttle cable or belt guides) after the first thirty days of purchase and any preventive maintenance as outlined in the operator's manual are NOT covered. In addition, you must cease using the product immediately upon any failure or damage, and take the product to an authorized servicing dealer prior to any further use.

WARRANTY EXCLUSIONS, DISCLAIMERS, AND LIMITED RIGHTS. WE WILL NOT BE LIABLE FOR ANY INCIDENTAL OR CONSEQUENTIAL DAMAGES. YOUR REMEDY IS LIMITED TO REPAIR OR REPLACEMENT OF THE PRODUCT OR PART, AT OUR DISCRETION. THERE ARE NO EXPRESS WARRANTIES OTHER THAN THOSE SET FORTH HEREIN. ANY WARRANTY IMPLIED BY STATE LAW (WHETHER OF MERCHANTABILITY OR FITNESS FOR A PARTICULAR USE OR OTHERWISE) IS HEREBY DISCLAIMED; WHERE

SUCH A DISCLAIMER IS NOT PERMITTED BY LAW, THEN SUCH IMPLIED WARRANTY IS LIMITED FOR THE DURATION OF THE APPLICABLE LIMITED WARRANTY PERIOD LISTED IN THE CHART BELOW. SOME LOCALITIES, INCLUDING THE PROVINCE OF QUEBEC, DO NOT ALLOW EXCLUSIONS OF INCIDENTAL OR CONSEQUENTIAL DAMAGES OR LIMITATIONS ON HOW LONG AN IMPLIED WARRANTY LASTS, SO THE ABOVE EXCLUSIONS AND LIMITATIONS MAY NOT APPLY TO YOU.

THIS LIMITED WARRANTY GIVES YOU SPECIFIC LEGAL RIGHTS, AND YOU MAY ALSO HAVE OTHER RIGHTS BASED ON YOUR LOCALITY.

How to obtain service. To obtain warranty service, you must contact one of our authorized Servicing Dealers/Centers (see the IFB submitted materials) or the Husqvarna representative identified in the IFB submitted materials, who will provide instructions on how to return a damaged or defective product/part or how to purchase a replacement part.

Husqvarna® Wheeled Warranty 2019		
<i>Wheeled Products Specific</i>	<i>Consumer</i> <i>(personal, household use)</i>	<i>Professional</i> <i>(any commercial, professional, agricultural, institutional or income producing use)</i>
Z200 Series	Bumper to Bumper 3 Years	No Warranty
Riding Lawn Mowers, Riding Lawn Tractors	Bumper to Bumper 3 Years	No Warranty
Lawn Mowers (Push or Walk, including Battery powered), Tiller	Bumper to Bumper 3 Years	No Warranty

Snowthrowers	Bumper to Bumper 3 Years	90 Days
Swedish Riders	3 Years	No Warranty
Log Splitter / Pressure Washers - PW-3200	2 Years	No Warranty
	Consumer (personal, household use)	Professional (any commercial, professional, agricultural, institutional or income producing use)
Robotic Mower	2 Years (includes Mower Battery)	2 Years (includes Mower Battery)
V500 - Stand-on Mowers	5 Years or 1500 hours	5 Years or 1500 hours
Z500X; PZ - Zero Turn Mowers	5 Years or 1500 hours	5 Years or 1500 hours
Z500; P-ZT - Zero Turn Mowers	5 Years or 1250 hours	5 Years or 1250 hours
M-ZT - Zero Turn Mowers	4 Years or 750 hours	4 Years or 750 hour
MZ - Zero Turn Mowers	4 Years or 400 hours	4 Years or 400 hour
Commercial W436, W448, W548, W552, L421P, Specialty Turf Care: Aerator, Bed Edger,	2 Years	2 Years

Dethatcher, Sodcutter, & Stumpgrinder.		
<p>Transferrable Warranty: This warranty may only be assigned or transferred to a second (or third) owner by an authorized Husqvarna dealer. The warranty period commences upon the date of the original retail purchase. Specifically for our Z500, V500 and W400, W500 series mowers only.</p>		
<p>Zero Turn Mowers - MZ, M-ZT, P-ZT, Z500, PZ, Z500X, V500: Warranty period is limited to whichever limit occurs first, years of operation or hours of operation.</p>		
<p>Husqvarna® Handheld Warranty 2019</p>		
<p>Battery Powered Handheld Products (Including corresponding Battery & Charger)</p>	<p>Consumer (personal, household use)</p>	<p>Professional (any commercial, professional, agricultural, institutional or income producing use)</p>
<p>535iXP, T535iXP, 520iHD60, 520iHE3, 520iLX, 530iP4, 530iPT5, 536LiLX, 536LiHD60X, 536LiXP, T536Li XP, 436LiB, 536LiP4, 536LiPT5</p> <p>Professional batteries: BLi80, BLi100, BLi150, BLi200, BLi300, BLi520X, BLi550X, BLi940X BLi950X</p> <p>Charger: QC330, QC500</p>	<p>3 Years</p>	<p>2 Years</p>
<p>115iL, 120i, 136Li, 136LiL, 136LiHD45, 115iHD55, 320iB, 336LiC</p> <p>Consumer batteries:BLi10, BLi20</p> <p>Charger: QC80</p>	<p>3 Years</p>	<p>90 Days</p>
<p>Handheld Products Specific (Gas Powered)</p>	<p>Consumer (personal, household use)</p>	<p>Professional (any commercial, professional, agricultural, institutional or income producing use)</p>

Chain Saws XP models including 365, 545, 555 and 565	2 Years	1 Year
Chain Saws non - XP models includes T435 and Electrical-corded models	2 Years	90 Days
200 and 300 Series Line Trimmers and Attachments (LK split boom attachments). Excludes the 345FR brushcutter.	2 Years	1 Year
100 Series Line Trimmers, 122 Series Hedgetrimmers, 125 Series Blowers, and Attachments (LD split boom attachments) and 130BT and 150BT blowers	2 Years	90 Days
All other handheld products (Includes 226 Hedgetrimmer, 345FR, 325HE3, 325HE4 & 430LS)	2 Years	2 Years
Power cutter	1 Year	1 Year
Husqvarna® Warranty 2019		
Other Products, Parts, and Accessories	Consumer (personal, household use)	Professional (any commercial, professional, agricultural, institutional or income producing use)
Composite Axes and Hatchets	Lifetime	Lifetime
Sprayers	5 Years / 1 Year on wear parts	5 Years / 1 Year on wear parts
Dump Carts, Snow Cabs, Push/Tow Spreaders,	2 Years	90 Days

Other Wheeled Attachments		
Baggers and Collection Systems	1 Year	90 Days
Wooden Axes and Hatchets	90 Days	30 Days
All other accessories (e.g., bars, chains, carrying cases, folding hand pruning saws, fixed hand pruning saws, personnel protective equipment, tools, toys, trimmer heads, trimmer guards, etc.)	90 Days	30 Days
Parts (e.g., belts, blades, starter covers, starter springs, etc.)	90 Days	90 Days
Reconditioned or Refurbished Products	30 Days	No Warranty

Husqvarna Warranty 2019 587 70 46-02 IR

Warranty information: Additional warranty information can be located on our website at www.husqvarna.com; click on Support; click on Warranty Coverage. Scroll down to the bottom of the page. Or use this link in a browser; husqvarna.custhelp.com/app/answers/detail/a_id/62/

Product Registration: Please register your product at www.husqvarna.com/us or www.husqvarna.com/ca. Thank you for choosing Husqvarna.

Additional Warranty Information - 2019

Battery: Lead Acid Batteries only: 180 days

Composite axe/hatchet: Limited Lifetime Warranty - defined as seven (7) years from Date of Purchase. Limited Lifetime warranty applies to the composite axe/hatchet only. The composite sheath is not covered under warranty.

Engines (4 stroke): Briggs & Stratton, Honda, Kawasaki, and Kohler engines are warranted by the engine manufacturer.

All other engines are warranted by Husqvarna as follows:

Snowthrowers and Tillers - 5 years.

Riding Mowers, Push or Walk Mowers, Zero Turn Mowers - 3 years.

Zero Turn Mowers with Yamaha Engines - 3 years.

Handheld and Tiller products: Handheld ignition modules, tiller tines, fabricated decks, and trimmer shafts all have a "Limited Lifetime Warranty," and are warranted for the life of the product or seven (7) years after the product's final production run, whichever comes first. Pole Saws and Pole Hedge Trimmers are excluded from the Shaft "Limited Lifetime Warranty."

Lawn Tractors: frame, chassis, and cast iron front axle have a five year consumer warranty.

Pressure Washers: Pressure Washer - PW3200 - All warranty is through Briggs and Stratton Power Products.

PZ / Z500 and P-ZT / Z500X / V500 products: Limited Lifetime Warranty on PZ / Z500 / P-ZT / Z500X / V500 Frame, PZ / Z500X / V500 only Spindle Housing, & PZ / Z500X / V500 only Leading Edge of Deck is for the life of the product or seven (7) years after the last date of the complete unit's final production, whichever comes first.

Residential Zero-Turn Mower and Tractor Decks:

Steel reinforced stamped deck shell only - 10 Year Limited Warranty.

Fabricated deck shell and Steel Guard deck shell - Limited Lifetime Warranty.

Limited to the original purchaser and is non-transferable. Replacement is limited to a maximum of two (2) deck shells. Parts and labor are included during the standard Product warranty period (see above). Labor is excluded after the standard Product warranty expires.

Mechanical components are not covered. Damage to cutting equipment by way of contact with rocks, sand or other objects, rust & corrosions, and natural discoloration of paint or other materials due to ultraviolet light are not covered.

Rental Warranty:

All Handheld Products (Battery / Electrical / Gas) the rental warranty time period is 90 days.

Tillers & Snowthrowers the rental warranty time period is 90 days. W436 & W448, Specialty Turf Care, Stump grinder, Aerator, Dethatcher, Sod cutter, Bed Edger the rental warranty time period is 1 year.

All other products do not have a rental warranty coverage.

Snow Throwers:

Aluminum auger gear box has a 5 year warranty.

Cast iron impeller and cast iron gear box has a 10 year warranty.

Transmissions: Hydro-Gear warrants transmission for three (3) years consumer use, parts and labor.

Transmissions: (Warranty period is limited to whichever limit occurs first, years of operation or hours of operation)

RZ, Z200 - (EZT Integrated transmission): Hydro-Gear warrants transmission for three (3) years consumer use, parts and labor.

MZ - (ZT3100 transmission): Hydro-Gear warrants transmission for two (2) year commercial use and three (3) years consumer use, parts and labor. M-ZT / P-ZT / Z500 - (ZT3400 transmission): Hydro-Gear warrants transmission for three (3) years, parts and labor.

PZ / Z500X - (Pump & Wheel Motor or ZT5400 transmission): Hydro-Gear warrants transmission for three (3) years, parts and labor.

V500 - Parker Pumps & Wheel Motors - (3) year warranty, as follows: Husqvarna warrants the first (1) year and second (2) year - parts and labor. Husqvarna the third (3) year - parts only, no labor.

Snow Throwers and Tractors: Hydro-Gear warrants transmission for three (3) years consumer use, parts and labor.

All other transmissions are warranted by Husqvarna as follows:

Peerless - three (3) years.

General Transmission - two (2) years. General Transmission CVT belt - ten (10) years.

Tuff Torq - three (3) years.

Returns

If you are not happy with your Husqvarna purchase for any reason, Husqvarna is happy to offer a convenient refund on all products identified below, minus any applicable shipping and/or restocking fees.

We will accept returns up to 30 days after delivery for all products shown in the table below provided they are:

- In new, fully functional, and undamaged condition
- In the original box, and include packing materials, manuals, and accessories
- For gas products, fuel has NEVER been put into the tank (even if it was drained)

Product	Models
Automower	ALL 100, 200 and 300 series models
Battery	ALL 100 and 300 series models
Blowers	All 100 and 300 series models
Brushcutters	All 200 and 300 series models
Chainsaws	All 100, 200 and 400 series models, excluding T435
Edgers	All 300 series models and LE475 Wheeled Edger
Hedge Trimmers	All 100 series models
Pole Saws	All 300 series models
Pressure Washers	All Models
Reel Mowers	Husqvarna 64
Snow Throwers	All models excluding 400 series models
String Trimmers	All 100, 200 and 300 series models
Tillers	All models
Tractors	All models excluding TS300 series and LS models, other than GTH52XLS, TS 348, and TS 354D
Walk Mowers	All models excluding commercial walk mowers and L421P
Zero-Turn Mowers	All Z100, Z200 and MZ models

*Collection Systems (Baggers) | Non - Blower Assist Collection Systems Only

Once gas has been put in an item, it is considered used and not returnable.

Some product categories due to their size and complexity will be subject to a restocking fee equal to a percentage of the pre-tax purchase price based on the below table.

Restocking Percentage			
Category	Percentage	Category	Percentage
Automower	30%	Snow Throwers	15%
Zero Turn Mowers	15%	Baggers	15%
Tractors	15%	Tractor Attachments	15%
Lawn Mowers	15%	Zero Turn Attachments	15%

For items that arrived damaged, defective, or not-working, we will be glad to send a replacement, refund or can refer you to one of our professional servicing centers to have it repaired. Replacement items and refunds will be sent at Husqvarna's discretion.

Shipping and handling charges are only refundable if the item was shipped in error on behalf of Husqvarna or if an item is damaged and a refund is given. Otherwise, shipping and handling charges are considered non-refundable.

Customers are responsible for all return shipping charges except when returning due to damage or defects. We suggest shipping the package with a carrier that can provide tracking and insurance, as Husqvarna is unable to provide credit for packages lost during shipment if proof of delivery is unavailable. For damaged or defective returns, Husqvarna will provide the appropriate shipping labels for your return.

All return requests need to be submitted to our Customer Care team through our website or phone call. When reaching out to Customer Care, please have your order number on hand and reason for your return, e.g. does not work, broken, do not want, etc. It is extremely important that a return authorization number be assigned for all returns prior to being shipped back. Equipment returned without a return authorization number prior to shipment may be rejected for refund consideration.

Please allow 10 – 15 business days from the date we receive the product for your refund to be credited to the credit card used for the original purchase.

All returns are subject to inspection by Husqvarna personnel as to identify possible use, misuse, missing components, damage or abuse. Refunds may be denied, or only partial credit given because of failure to pass a return inspection.

Return Location

All purchases will be returned to our Charlotte facility at:

Attn: Returns Dept
Husqvarna
7600 Statesville RD
Charlotte, NC 28269

Tax Policy

All purchases will be charged applicable state and local taxes. Sales tax will be calculated based on the ship-to address and the sales tax rate in effect at the time of shipping. If no sales tax is charged, purchaser may still be responsible for paying the sales tax where required. The purchase is not tax-exempt because the seller is not required to collect sales tax. Purchasers should check their respective state's tax website for additional information or seek advice from a tax or legal professional.



Association of Educational
PURCHASING AGENCIES

Recommendation for New Contracts

AEPA IFB Click or tap here to enter text.

Instructions

Send this completed, signed recommendation, with supporting documents attached, to Tammy Hurst, AEPA President, George Wilson, AEPA Executive Director and Jane Eastes, AEPA Bid Chair no later than **Friday, October 11, 2019**.

Signatures:

Committee Chair: Ted Witt

Committee Member: Andrew Pickins

Committee Member: Rob Naughton

Committee Member: Steve Griggs

Methodology Used by the Committee for Determination:

XX Low responsive and responsible bidder(s) based on the attached price tabulation. (Each bidder was the sole low bidder in their respective categories.)

 Low responsive and responsive bidder(s) based on the attached market basket study tabulation.

 Responsive and responsible bidder(s) based on the highest catalog discount.

Bids received that were rejected PRIOR to evaluation with cause for rejection:

N/A

Bids received that were rejected DURING evaluation with cause for rejection:

SMG, non-responsive due to unanswered co-op marketing questions, narrow dealer network, no evidence of financial viability, and bid for a single product instead of catalog.

Vendors recommended with reason for recommendation:

- Bobcat: Lowest Responsive Responsible Bidder in the category of Utility Vehicles and Turf Tractors
- Husqvarna: Lowest Responsive, Responsible Bidder in the categories of stand-on mowers, zero turn mowers, small mowers and grounds tools

Proposed Motion:

It is recommended by the Category Committee that AEPA reject the bids from SMG.

Proposed Motion:

It is recommended by the Category Committee that AEPA approve the bids from

- Husqvarna
- Bobcat

for a recommended contract by our participating member agencies.

Lanscaping and Grounds Equipment

Evaluation Factors	Bobcat	SMG	Husvarna
Cost Evaluation	Lowest, responsive, responsible bidder in categories of Utility Vehicles and Turf Tractors	Non-responsive because it only bid one item	Lowest, responsive, responsible bidder in categories of Stand-On mowers, Zero Turn Mowers, Small mowers and Grounds Tools
Complete Response to Bid	Responsive	Non-responsive because it only bid one item	Responsive
Conformance to Bid Terms and Conditions	Exceptions; non-conforming to price schedule	Non-conforming to price schedule, to local service	Has exceptions
Pricing Equal to or Better Than That Offered to Individual Entities or Cooperatives With Equal or Lesser Volume	Equal to	3% lower	Equal to
Quality and Suitability of Products Offered	Satisfactory	Satisfactory	Satisfactory
Marketing Plan	Satisfactory	No responsive to cooperative marketing section	Satisfactory
Financial Viability	Satisfactory Annual Report Provided	No evidence in hand to committee	Satisfactory, annual report provided, normal corporate lawsuits
Demonstrated Track Record of Performance in the Public Marketplace	Satisfactory	Only 1.2 million for all sectors including private	Satisfactory; big in cities & counties, room to grow in education
Value Added Attributes	Large Dealer Base	Tiny Dealer Base	Large Dealer Base

Bobcat Catalog Discounts		
Bobcat® Compact Utility Tractors	20%	Factory installed options receive 20% off MSRP. All Attachments receive 24% off MSRP
Bobcat® Toolcats	20%	Factory installed options receive 20% off MSRP. All Attachments receive 24% off MSRP
Bobcat® Utility Vehicles	20%	Factory installed options receive 20% off MSRP. All Attachments receive 24% off MSRP
Bobcat® Mini-Track Loaders	20%	Factory installed options receive 20% off MSRP. All Attachments receive 24% off MSRP

Bobcat Equivalent Core and Non-Core Pricing

Bobcat® Compact Utility Tractor	CT1021HST COMPACT UTILITY TRACTOR	Bobcat Company	M1601	EA	\$ 11,527.00	20.0%	\$ 9,221.60	20% off Published MSRP of all factory installed options. 24% off attachments
Bobcat® Compact Utility Tractor	CT1025HST COMPACT UTILITY TRACTOR	Bobcat Company	M1602	EA	\$ 13,922.00	20.0%	\$11,137.60	20% off Published MSRP of all factory installed options. 24% off attachments
Bobcat® Compact Utility Tractor	CT2025HST COMPACT TRACTOR	Bobcat Company	M1603	EA	\$ 16,560.00	20.0%	\$13,248.00	20% off Published MSRP of all factory installed options. 24% off attachments
Bobcat® Compact Utility Tractor	CT2025MST COMPACT TRACTOR	Bobcat Company	M1604	EA	\$ 15,284.00	20.0%	\$12,227.20	20% off Published MSRP of all factory installed options. 24% off attachments
Bobcat® Compact Utility Tractor	CT2035HST COMPACT TRACTOR	Bobcat Company	M1605	EA	\$ 20,797.00	20.0%	\$16,637.60	20% off Published MSRP of all factory installed options. 24% off attachments
Bobcat® Compact Utility Tractor	CT2035MST COMPACT TRACTOR	Bobcat Company	M1606	EA	\$ 19,485.00	20.0%	\$15,588.00	20% off Published MSRP of all factory installed options. 24% off attachments
Bobcat® Compact Utility Tractor	CT2040HST COMPACT TRACTOR	Bobcat Company	M1607	EA	\$ 21,343.00	20.0%	\$17,074.40	20% off Published MSRP of all factory installed options. 24% off attachments
Bobcat® Compact Utility Tractor	CT2040MST COMPACT TRACTOR	Bobcat Company	M1608	EA	\$ 20,008.00	20.0%	\$16,006.40	20% off Published MSRP of all factory installed options. 24% off attachments
Bobcat® Compact Utility Tractor	CT2535HST COMPACT TRACTOR	Bobcat Company	M1609	EA	\$ 30,804.00	20.0%	\$24,643.20	20% off Published MSRP of all factory installed options. 24% off attachments
Bobcat® Compact Utility Tractor	CT2540HST COMPACT TRACTOR	Bobcat Company	M1611	EA	\$ 32,355.00	20.0%	\$25,884.00	20% off Published MSRP of all factory installed options. 24% off attachments
Bobcat® Compact Utility Tractor	CT4045HST COMPACT TRACTOR	Bobcat Company	M1613	EA	\$ 26,043.00	20.0%	\$20,834.40	20% off Published MSRP of all factory installed options. 24% off attachments
Bobcat® Compact Utility Tractor	CT4045SST COMPACT TRACTOR	Bobcat Company	M1614	EA	\$ 23,884.00	20.0%	\$19,107.20	20% off Published MSRP of all factory installed options. 24% off attachments
Bobcat® Compact Utility Tractor	CT4050HST COMPACT TRACTOR	Bobcat Company	M1615	EA	\$ 29,545.00	20.0%	\$23,636.00	20% off Published MSRP of all factory installed options. 24% off attachments
Bobcat® Compact Utility Tractor	CT4050SST COMPACT TRACTOR	Bobcat Company	M1616	EA	\$ 25,105.00	20.0%	\$20,084.00	20% off Published MSRP of all factory installed options. 24% off attachments
Bobcat® Compact Utility Tractor	CT4055SST COMPACT TRACTOR	Bobcat Company	M1617	EA	\$ 26,327.00	20.0%	\$21,061.60	20% off Published MSRP of all factory installed options. 24% off attachments
Bobcat® Compact Utility Tractor	CT4058SST COMPACT TRACTOR	Bobcat Company	M1618	EA	\$ 31,486.00	20.0%	\$25,188.80	20% off Published MSRP of all factory installed options. 24% off attachments
Bobcat® Compact Utility Tractor	CT5545E-HST COMPACT TRACTOR	Bobcat Company	M1619	EA	\$ 35,895.00	20.0%	\$28,716.00	20% off Published MSRP of all factory installed options. 24% off attachments
Bobcat® Compact Utility Tractor	CT5550E-HST COMPACT TRACTOR	Bobcat Company	M1620	EA	\$ 37,734.00	20.0%	\$30,187.20	20% off Published MSRP of all factory installed options. 24% off attachments
Bobcat® Compact Utility Tractor	CT5555E-HST COMPACT TRACTOR	Bobcat Company	M1621	EA	\$ 39,697.00	20.0%	\$31,757.60	20% off Published MSRP of all factory installed options. 24% off attachments
Bobcat® Compact Utility Tractor	CT5558E-HST COMPACT TRACTOR	Bobcat Company	M1622	EA	\$ 42,583.00	20.0%	\$34,066.40	20% off Published MSRP of all factory installed options. 24% off attachments
Bobcat® Mini-Track Loader	MT55 Mini Track Loader (Equipped with Tier 4 Engine)	Bobcat Company	M0045	EA	\$ 23,022.00	20.0%	\$18,417.60	20% off Published MSRP of all factory installed options. 24% off attachments
Bobcat® Mini-Track Loader	MT85 Mini Track Loader (Equipped with Tier 4 Engine)	Bobcat Company	M0113	EA	\$ 27,327.00	20.0%	\$21,861.60	20% off Published MSRP of all factory installed options. 24% off attachments

Bobcat® Toolcat™	5600 Turbo Utility Work Machine (Tier	Bobcat Company	M1221	EA	\$ 53,404.00	20.0%	\$42,723.20	20% off Published MSRP of all factory installed options. 24% off attachments
Bobcat® Toolcat™	5610 Turbo Utility Work Machine – Deluxe Version (Tier 4)	Bobcat Company	M1223	EA	\$ 67,554.00	20.0%	\$54,043.20	20% off Published MSRP of all factory installed options. 24% off attachments
Bobcat® Utility Vehicle	3400 Utility Vehicle - Gas	Bobcat Company	M1303	EA	\$ 13,420.00	20.0%	\$10,736.00	20% off Published MSRP of all factory installed options. 24% off attachments
Bobcat® Utility Vehicle	3400XL Utility Vehicle - Gasoline	Bobcat Company	M1307	EA	\$ 15,440.00	20.0%	\$12,352.00	20% off Published MSRP of all factory installed options. 24% off attachments
Bobcat® Utility Vehicle	UV34 Utility Vehicle- Diesel	Bobcat Company	M1501	EA	\$ 16,406.00	20.0%	\$13,124.80	20% off Published MSRP of all factory installed options. 24% off attachments
Bobcat® Utility Vehicle	UV34XL Utility Vehicle - Diesel	Bobcat Company	M1505	EA	\$ 17,886.00	20.0%	\$14,308.80	20% off Published MSRP of all factory installed options. 24% off attachments

Husqvarna Catalog Discounts

Z500 Zero Turn Mowers	30%	Z500 Series Zero Turn Mowers
Zero Turn Mowers	20%	Z100, Z200, Z400 (Commercial), MZ, and MZ-T (Commercial) Zero Turn Mowers
Lawn Tractors	20%	All lawn tractors included in Non-Core Price Schedule
Stand-On Zero Turn Units	20%	V500 Series Stand-On Mowers
Handheld Equipment	20%	Chainsaws, Blowers, String Trimmers, Edgers, Brushcutters, Edgers, and Pole Saws
Specialty Turf Equipment	20%	Stump Grinder, Aerator, Power Rake, Sod Cutter, Seeder, and Bed Edger
Snow Equipment	20%	Snow Throwers
Robotic Mowers	10%	For Automowers included in Non-Core Price Schedule
Attachments/ Accessories	15%	For items included in Non-Core Price Schedule
Installation Service for Robotic Mowers	0%	See Pricing below for installation pricing associated with each model of Automower

Husqvarna Equivalent Core and Non-Core Pricing

Husqvarna - 120i, 14", 3/8 pitch, .043 gauge Batt Chainsaw kit w/batt & charger	967098102	Each	\$ 259.99	20%	\$ 207.99
Husqvarna 125BVX, 28 cc handheld blower with vac kit, 1.1 hp., 425 cfm/170 mph	952711902	Each	\$ 199.99	20%	\$ 159.99
Husqvarna 129LK, 28cc detachable shaft trimmer, LK attachments (power head single pac)	967680502	Each	\$ 169.99	20%	\$ 135.99
Husqvarna V548, 24.5 HP Kawasaki FX751V, 48", 7 Ga. Fab, 12cc Parker	967672501	Each	\$ 8,899.99	20%	\$7,119.99
Husqvarna V554, 24.5 HP Kawasaki FX751V, 54", 7 Ga. Fab, 12cc Parker	967672601	Each	\$ 8,999.99	20%	\$7,199.99
Husqvarna Z448, 22 HP Kawasaki FS,	967984601	Each	\$ 5,999.99	20%	\$4,799.99
Husqvarna Z554X, 27.5 HP Yamaha MX825V, 54in/7ga Fab, ZT5400, Susp Seat, with Z554X 9 Bushel Collection System	967930001, 967322401	Each	\$ 13,398.99	27%	\$9,739.14
Husqvarna Z560, 25.5 HP Kawasaki FX751V, 60in/10ga Fab, ZT4400	967678401	Each	\$ 9,299.99	30%	\$6,509.99
Z500 Zero Turn Mowers	Z554X	Each	\$ 11,299.99	30.0%	\$7,909.99
Z500 Zero Turn Mowers	Z554X	Each	\$ 10,999.99	30.0%	\$7,699.99
Z500 Zero Turn Mowers	Z560	Each	\$ 9,299.99	30.0%	\$6,509.99
					29 HP Yamaha MX775V EFI, 54in/7ga Fab, ZT5400, Susp Seat
					27.5 HP Yamaha MX825V, 54in/7ga Fab, ZT5400, Susp Seat
					25.5 HP Kawasaki FX751V, 60in/10ga Fab, ZT4400

Z500 Zero Turn Mowers	Z560x	Each	\$ 11,899.99	30.0%	\$8,329.99	27.5 HP Yamaha MX825V, 60in/7ga Fab, ZT5400, Susp Seat
Z500 Zero Turn Mowers	Z560X 50 STATE	Each	\$ 11,999.99	30.0%	\$8,399.99	27.5 HP Yamaha MX825V, 60in/7ga Fab, ZT5400, Susp Seat, 50 State
Z500 Zero Turn Mowers	Z572X	Each	\$ 13,399.99	30.0%	\$9,379.99	33 HP Yamaha MX825V EFI, 72in/7ga Fab, ZT5400, Susp Seat
Z500 Zero Turn Mowers	Z560X	Each	\$ 12,599.99	30.0%	\$8,819.99	31 HP Yamaha MX800V EFI , 60in/7ga Fab, ZT5400, Susp Seat
Z500 Zero Turn Mowers	Z572X	Each	\$ 13,299.99	30.0%	\$9,309.99	31 HP Kawasaki FX921V, 72in/7ga Fab, ZT5400, Susp Seat
Z500 Zero Turn Mowers	Z560X	Each	\$ 12,499.99	30.0%	\$8,749.99	31 HP Kawasaki FX921V, 60in/7ga Fab, ZT5400, Susp Seat
Zero Turn Mowers	Z448	Each	\$ 5,999.99	20.0%	\$4,799.99	22 HP Kawasaki FS, 48" FAB
Zero Turn Mowers	Z454 50ST	Each	\$ 6,499.99	20.0%	\$5,199.99	22 HP Kawasaki FS, 54" FAB, 50 STATE
Zero Turn Mowers	Z460	Each	\$ 6,999.99	20.0%	\$5,599.99	23 HP Kawasaki FS, 60" FAB
Zero Turn Mowers	Z454X	Each	\$ 8,499.99	20.0%	\$6,799.99	22 HP Kawasaki FX, 54" FAB
Zero Turn Mowers	Z460X	Each	\$ 8,999.99	20.0%	\$7,199.99	23.5 HP Kawasaki FX, 60" FAB
Zero Turn Mowers	Z254 Intek	Each	\$ 2,699.99	20.0%	\$2,159.99	22 HP Intek , 54" Stamped/Reinforced deck, 3 blade 4" caster
Zero Turn Mowers	Z254F	Each	\$ 2,999.99	20.0%	\$2,399.99	23 HP Kawasaki, 54 ClearCut, 6" Caster
Zero Turn Mowers	Z242F	Each	\$ 2,799.99	20.0%	\$2,239.99	18 HP Kawasaki FR, 42 ClearCut, 6" Casters, Deluxe 15" Seat
Zero Turn Mowers	Z142	Each	\$ 2,599.99	20.0%	\$2,079.99	17 HP Kohler, 42" Stamped, 2 Blade
Zero Turn Mowers	Z248F	Each	\$ 2,899.99	20.0%	\$2,319.99	21.5 HP Kawasaki FR, 48 ClearCut®, 6" Casters
Zero Turn Mowers	Z242F CARB	Each	\$ 2,899.99	20.0%	\$2,319.99	18 HP Kawasaki FR, 42 ClearCut, 6" Casters, Deluxe 15" Seat CARB
Zero Turn Mowers	Z254	Each	\$ 2,799.99	20.0%	\$2,239.99	24 HP Endurance , 54" Stamped/Reinforced deck, 3 blade 6" caster
Zero Turn Mowers	Z246	Each	\$ 2,699.99	20.0%	\$2,159.99	20 HP Endurance, 46" Stamped / Reinforced, 2 blade, 4" Caster
Zero Turn Mowers	Z254	Each	\$ 2,899.99	20.0%	\$2,319.99	26 HP Kohler 7000 , 54" Stamped / Reinforced deck, 3 Blade, 6" Casters
Zero Turn Mowers	Z248F CARB	Each	\$ 2,999.99	20.0%	\$2,399.99	21.5 HP Kawasaki FR, 48 ClearCut®, 6" Casters, CARB
Zero Turn Mowers	Z254F	Each	\$ 3,299.99	20.0%	\$2,639.99	26 HP Kohler 7000, 54 ClearCut, 6" Caster, CI Spindle, LED + New SEAT + Armrests
Zero Turn Mowers	Z248F	Each	\$ 3,199.99	20.0%	\$2,559.99	26 HP Kohler 7000, 48 ClearCut®, 6" Casters, CI Spindle, LED + New SEAT + Armrests

Zero Turn Mowers	MZ54	Each	\$ 4,999.99	20.0%	\$3,999.99	23 HP Kohler Confidant, 54" ClearCut, 3 blade, ZT3100 (M-ZT seat)
Zero Turn Mowers	MZ54+ROPS	Each	\$ 5,299.99	20.0%	\$4,239.99	24 HP Kawasaki , 54" ClearCut® deck, 3 blade, ZT3100 ROPS
Zero Turn Mowers	MZ48 CARB	Each	\$ 4,699.99	20.0%	\$3,759.99	23 HP Kohler 7000 H/D filter, 48" ClearCut®, ZT3100 (M-ZT seat), CARB
Zero Turn Mowers	MZ61+ROPS	Each	\$ 5,499.99	20.0%	\$4,399.99	24 HP Kawasaki FR, 61" Fabricated deck, 3 blade, ZT3100 (M-ZT seat) ROPS
Zero Turn Mowers	MZ61	Each	\$ 5,199.99	20.0%	\$4,159.99	27 HP Endurance , 61" Fabricated deck, 3 blade, ZT3100 (M-ZT seat)
Zero Turn Mowers	MZ48	Each	\$ 4,799.99	20.0%	\$3,839.99	23 HP Kohler 7000 H/D filter, 48" ClearCut® ZT3100 (M-ZT seat)
Zero Turn Mowers	Z246	Each	\$ 3,999.99	20.0%	\$3,199.99	18.5 HP Kawasaki FR600V, 46" Stamped Reinforced Cutting Deck, 2 Blade, LED Headlight, Wide Casters
Zero Turn Mowers	Z248F	Each	\$ 4,999.99	20.0%	\$3,999.99	23 HP Kawasaki FR691V, 48" ClearCut deck, 3 blade, Cast Iron Spindles, 6" Wide Casters, Headlights, Armrest Kit
Zero Turn Mowers	Z242F	Each	\$ 4,999.99	20.0%	\$3,999.99	21.5HP Kawi FR651V, 42" ClearCut deck, 2 blade, wide casters, Cast Iron Spindles, Headlights, Armrest Kit
Zero Turn Mowers	Z242E	Each	\$ 4,999.99	20.0%	\$3,999.99	21.5 HP Kawi FR651V, Cast Aluminum Spindles, Narrow Yokes & Casters, ClearCut Deck
Lawn Tractors	TS 348D CARB	Each	\$ 3,299.99	20.0%	\$2,639.99	24 Kohler, 48" ClearCut™ w/CI Spindle, Hydro, MZ Seat, Tube Bumper, ELD, CARB\
Lawn Tractors	TS 348D	Each	\$ 3,299.99	20.0%	\$2,639.99	24 Kohler, 48" ClearCut™ w/CI Spindle, Hydro, MZ Seat, Tube Bumper, ELD
Lawn Tractors	TS 354XD	Each	\$ 3,799.99	20.0%	\$3,039.99	26HP Kohler w/Smart Choke, 54" ClearCut™ w/CI Spindle, Hydro, Deluxe 18" Seat, , , Brush Guard, Locking Diff
Lawn Tractors	TS 354X	Each	\$ 3,599.99	20.0%	\$2,879.99	26HP Kohler w/Smart Choke, 54" ClearCut™ w/CI Spindle, Fast Hydro, Deluxe 18" Seat, , Brush Guard
Lawn Tractors	TS 348XD	Each	\$ 3,599.99	20.0%	\$2,879.99	26HP Kohler w/Smart Choke, 48" ClearCut™ w/CI Spindle, Hydro, Deluxe 18" Seat, Locking Diff, , Brush Guard
Lawn Tractors	TS 354D	Each	\$ 3,699.99	20.0%	\$2,959.99	25HP Kohler , 54" ClearCut™, Elec PTO, Elec Diff, Pedal Auto, Brush Guard

Lawn Tractors	YTH18542	Each	\$ 1,699.99	20.0%	\$1,359.99	18.5HP B&S Intek single, 42" Reinforced deck, Hydro, Pedal
Lawn Tractors	YTH18542 CARB	Each	\$ 1,799.99	20.0%	\$1,439.99	18.5HP B&S 42" Reinforced deck, Man PTO, Pedal Hydro CARB
Lawn Tractors	YTH24V48 CARB	Each	\$ 2,099.95	20.0%	\$1,679.96	24HP B&S Intek, 48" Reinforced deck, Hydro, Pedal, LOWES, CARB
Lawn Tractors	YTH22V46	Each	\$ 1,899.99	20.0%	\$1,519.99	22HP B&S Intek, 46" Reinforced Hydro, Pedal
Lawn Tractors	YTH24V48	Each	\$ 2,099.99	20.0%	\$1,679.99	24HP B&S Intek, 48" Reinforced deck, Hydro, Pedal,
Lawn Tractors	YTH22V46 CARB	Each	\$ 1,999.99	20.0%	\$1,599.99	22HP B&S Intek, 46" Reinforced deck, Hydro, Pedal CARB
Lawn Tractors	YTH24V54	Each	\$ 2,199.95	20.0%	\$1,759.96	24HP B&S, 54" Reinforced deck, Hydro, Pedal
Lawn Tractors	YTH24V54 CARB	Each	\$ 2,299.95	20.0%	\$1,839.96	24HP B&S, 54" Reinforced deck, Hydro, Pedal CARB LOWES
Lawn Tractors	TS 242	Each	\$ 2,599.99	20.0%	\$2,079.99	22HP Kohler w/SC , 42" ClearCut™ deck, Dual Pedal Hydro, New Hood/GT Fender & Grips, 20x10, Tube Bumper
Lawn Tractors	LGT48DXL	Each	\$ 2,699.95	20.0%	\$2,159.96	25HP Kohler, 48" ClearCut™ , Elec PTO, Lever Hydro, Tube Bumper
Stand-On Zero Turn Units	V548	Each	\$ 8,899.99	20.0%	\$7,119.99	24.5 HP Kawasaki FX751V, 48", 7 Ga. Fab, 12cc Parker
Stand-On Zero Turn Units	V554	Each	\$ 8,999.99	20.0%	\$7,199.99	24.5 HP Kawasaki FX751V, 54", 7 Ga. Fab, 12cc Parker
Handheld Equipment	572XP	Each	\$ 1,019.99	20.0%	\$ 815.99	24", 3/8 pitch, .050 ga. 70.7cc chainsaw
Handheld Equipment	572XP	Each	\$ 1,019.99	20.0%	\$ 815.99	24", 3/8 pitch, .058 ga. 70.7cc chainsaw
Handheld Equipment	572XP	Each	\$ 1,029.99	20.0%	\$ 823.99	28", 3/8 pitch, .063 ga. 70.7cc chainsaw
Handheld Equipment	572XP	Each	\$ 1,029.99	20.0%	\$ 823.99	28", 3/8 pitch, .050 ga. 70.7cc chainsaw
Handheld Equipment	572XP	Each	\$ 1,029.99	20.0%	\$ 823.99	28", 3/8 pitch, .058 ga. 70.7cc chainsaw
Handheld Equipment	390XP	Each	\$ 1,179.99	20.0%	\$ 943.99	20", 3/8 pitch, .050 ga. 88cc chainsaw
Handheld Equipment	390XP	Each	\$ 1,179.99	20.0%	\$ 943.99	20", 3/8 pitch, .058 ga. 88cc chainsaw
Handheld Equipment	390XP	Each	\$ 1,199.99	20.0%	\$ 959.99	24", 3/8 pitch, .050 ga. 88cc chainsaw
Handheld Equipment	390XP	Each	\$ 1,199.99	20.0%	\$ 959.99	24", 3/8 pitch, .058 ga. 88cc chainsaw
Handheld Equipment	390XP	Each	\$ 1,199.99	20.0%	\$ 959.99	24", 3/8 pitch, .063 ga. 88cc chainsaw
Handheld Equipment	572XP	Each	\$ 1,059.99	20.0%	\$ 847.99	32", 3/8 pitch, .063 ga. 70.7cc chainsaw
Handheld Equipment	555	Each	\$ 699.99	20.0%	\$ 559.99	20", 3/8 pitch, .058 ga. 59.8cc chainsaw
Handheld Equipment	555	Each	\$ 699.99	20.0%	\$ 559.99	20", 3/8 pitch, .050 ga. 59.8cc chainsaw
Handheld Equipment	390XP	Each	\$ 1,229.99	20.0%	\$ 983.99	28", 3/8 pitch, .050 ga. 88cc chainsaw

Handheld Equipment	390XP	Each	\$ 1,229.99	20.0%	\$ 983.99	28", 3/8 pitch, .058 ga. 88cc chainsaw
Handheld Equipment	390XP	Each	\$ 1,229.99	20.0%	\$ 983.99	28", 3/8 pitch, .063 ga. 88cc chainsaw
Handheld Equipment	390XP	Each	\$ 1,249.99	20.0%	\$ 999.99	32", 3/8 pitch, .050 ga. 88cc chainsaw
Handheld Equipment	390XP	Each	\$ 1,249.99	20.0%	\$ 999.99	32", 3/8 pitch, .063 ga. 88cc chainsaw
Handheld Equipment	555	Each	\$ 719.99	20.0%	\$ 575.99	24", 3/8 pitch, .050 ga. 59.8cc chainsaw
Handheld Equipment	545 II	Each	\$ 579.99	20.0%	\$ 463.99	20", .325 pitch, .050 ga., 50.1cc chainsaw
Handheld Equipment	390XP	Each	\$ 1,279.99	20.0%	\$1,023.99	36", 3/8 pitch, .063 ga. 88cc chainsaw
Handheld Equipment	535IXP	Each	\$ 429.99	20.0%	\$ 343.99	14", 3/8 pitch, .043 gauge XP batt chainsaw, w/o batt & charger
Handheld Equipment	T535iXP	Each	\$ 429.99	20.0%	\$ 343.99	12", 3/8 pitch, .043 gauge Top Handle Batt saw, w/o batt & charger
Handheld Equipment	525HF3S	Each	\$ 459.99	20.0%	\$ 367.99	25.4cc 10 foot reach pro fixed hedge trimmer, 26", 13.2lbs.
Handheld Equipment	T435	Each	\$ 329.99	20.0%	\$ 263.99	12", 3/8 pitch, .050 ga. 35.2cc top handle chainsaw
Handheld Equipment	T435	Each	\$ 349.99	20.0%	\$ 279.99	14", 3/8 pitch, .050 ga. 35.2cc top handle chainsaw
Handheld Equipment	520IHE3	Each	\$ 449.99	20.0%	\$ 359.99	40v 10 foot reach battery articulating hedge trim w/o batt & charger
Handheld Equipment	565	Each	\$ 939.99	20.0%	\$ 751.99	20", 3/8 pitch, .050 ga. 70.7cc chainsaw
Handheld Equipment	565	Each	\$ 939.99	20.0%	\$ 751.99	20", 3/8 pitch, .058 ga. 70.7cc chainsaw
Handheld Equipment	565	Each	\$ 949.99	20.0%	\$ 759.99	24", 3/8 pitch, .050 ga. 70.7cc chainsaw
Handheld Equipment	565	Each	\$ 949.99	20.0%	\$ 759.99	24", 3/8 pitch, .058 ga. 70.7cc chainsaw
Handheld Equipment	565	Each	\$ 959.99	20.0%	\$ 767.99	28", 3/8 pitch, .050 ga. 70.7cc chainsaw
Handheld Equipment	565	Each	\$ 959.99	20.0%	\$ 767.99	28", 3/8 pitch, .058 ga. 70.7cc chainsaw
Handheld Equipment	525ECS	Each	\$ 319.99	20.0%	\$ 255.99	25.4cc flex drive, curved shaft stick edger
Handheld Equipment	325HE3	Each	\$ 499.99	20.0%	\$ 399.99	25.4cc 10 foot reach pro articulating hedge trimmer, 22"
Handheld Equipment	522L	Each	\$ 259.99	20.0%	\$ 207.99	22.5cc semi professional trimmer, steel drive shaft, 1.0hp, 9.0 lbs.
Handheld Equipment	T435	Each	\$ 379.99	20.0%	\$ 303.99	16", 3/8 pitch, .050 ga. 35.2cc top handle chainsaw
Handheld Equipment	545 II	Each	\$ 489.99	20.0%	\$ 391.99	POWERHEAD
Handheld Equipment	545 II	Each	\$ 539.99	20.0%	\$ 431.99	16", .325 pitch, .050 ga., 50.1cc chainsaw
Handheld Equipment	545 II	Each	\$ 539.99	20.0%	\$ 431.99	16", .325 pitch, .058 ga., 50.1cc chainsaw
Handheld Equipment	545 II	Each	\$ 549.99	20.0%	\$ 439.99	18", .325 pitch, .050 ga., 50.1cc chainsaw

Handheld Equipment	530IP4	Each	\$	399.99	20.0%	\$	319.99	40v fixed battery pole saw w/o battery & charger
Handheld Equipment	520IHD60	Each	\$	449.99	20.0%	\$	359.99	40V double side batt hedge trimmer, 24", w/o batt & chrgr
Handheld Equipment	325HE4	Each	\$	549.99	20.0%	\$	439.99	25.4cc 13 foot reach pro articulating hedge trimmer, 22"
Handheld Equipment	524LK	Each	\$	449.99	20.0%	\$	359.99	25cc four stroke trimmer, detachable, 1.1hp, 11.9lbs.
Handheld Equipment	525ES	Each	\$	399.99	20.0%	\$	319.99	25.4cc steel drive, straight shaft stick edger
Handheld Equipment	520ILX	Each	\$	299.99	20.0%	\$	239.99	40V straight shaft battery trimmer w/o batt & charger, blade capable
Handheld Equipment	525L	Each	\$	299.99	20.0%	\$	239.99	25.4cc professional trimmer, steel drive shaft, 1.2hp, 9.7lbs.
Handheld Equipment	545 II	Each	\$	549.99	20.0%	\$	439.99	18", .325 pitch, .058 ga., 50.1cc chainsaw
Handheld Equipment	570BFS	Each	\$	499.99	20.0%	\$	399.99	65 cc frame throttle b/p blower, 770 cfm/236 mph, 24.5 lbs.
Handheld Equipment	570BTS	Each	\$	499.99	20.0%	\$	399.99	65 cc tube throttle b/p blower, 770 cfm/236 mph, 24.5 lbs.
Handheld Equipment	525LS	Each	\$	319.99	20.0%	\$	259.99	25.4cc pro trimmer, steel dr. shaft, bikini guard, scaper handle, 1.3hp, 10.1lbs.
Handheld Equipment	550XPG II	Each	\$	669.99	20.0%	\$	535.99	16", .325 pitch, .050 ga., 50.1cc heated handle chainsaw
Handheld Equipment	550XP II	Each	\$	599.99	20.0%	\$	479.99	16", .325 pitch, .050 ga. 50.1cc chainsaw
Handheld Equipment	550XP II	Each	\$	599.99	20.0%	\$	479.99	16", .325 pitch, .058 ga. 50.1cc chainsaw
Handheld Equipment	550XPG II	Each	\$	679.99	20.0%	\$	543.99	18", .325 pitch, .050 ga., 50.1cc heated handle chainsaw
Handheld Equipment	560BFS	Each	\$	459.99	20.0%	\$	367.99	65 cc frame throttle b/p blower, 632 cfm/232 mph, 23.4 lbs.
Handheld Equipment	550XP II	Each	\$	609.99	20.0%	\$	487.99	18", .325 pitch, .050 ga. 50.1cc chainsaw
Handheld Equipment	550XP II	Each	\$	609.99	20.0%	\$	487.99	18", .325 pitch, .058 ga. 50.1cc chainsaw
Handheld Equipment	550XP II	Each	\$	619.99	20.0%	\$	495.99	20", .325 pitch, .058 ga. 50.1cc chainsaw
Handheld Equipment	525LST	Each	\$	339.99	20.0%	\$	271.99	25.4cc pro trimmer, hi torque steel dr. sftt, bikini grd, scaper handle, 1.3hp, 10.4lbs.
Handheld Equipment	560BTS	Each	\$	459.99	20.0%	\$	367.99	65 cc tube throttle b/p blower, 632 cfm/232 mph, 23.4 lbs.
Handheld Equipment	530IPT5	Each	\$	499.99	20.0%	\$	399.99	40v telescopic battery pole saw w/o battery & charger
Handheld Equipment	525RX	Each	\$	399.99	20.0%	\$	319.99	25.4cc bike handle steel drive brushcutter

Handheld Equipment	580BFS II	Each	\$	569.99	20.0%	\$	455.99	76 cc frame throttle b/p blower, 936 cfm/205 mph, 25.8 lbs.
Handheld Equipment	580BTS II	Each	\$	569.99	20.0%	\$	455.99	76 cc tube throttle b/p blower, 936 cfm/205 mph, 25.8 lbs.
Handheld Equipment	525LK	Each	\$	399.99	20.0%	\$	319.99	25.4cc detachable pro trimmer, 1.3hp,
Handheld Equipment	535LK	Each	\$	499.99	20.0%	\$	399.99	34.6cc detachable pro trimmer,
Handheld Equipment	525P5S	Each	\$	579.99	20.0%	\$	463.99	25.4cc 16 foot reach split boom professional pole saw
Handheld Equipment	436LiB	Each	\$	249.99	20.0%	\$	199.99	40V Li-Ion handheld blower, 388cfm/105mph, w/o batt & cger
Handheld Equipment	525P4S	Each	\$	499.99	20.0%	\$	399.99	25.4cc 13 foot reach professional pole saw
Handheld Equipment	430LS	Each	\$	399.99	20.0%	\$	319.99	29.5 cc professional trimmer, steel drive shaft, 1.3hp, 11.2lbs.
Handheld Equipment	543XP	Each	\$	529.99	20.0%	\$	423.99	16", .325 pitch, .050 ga. 43.1cc chainsaw
Handheld Equipment	545FR	Each	\$	849.99	20.0%	\$	679.99	45.7cc bike handle pro brushcutter w/line, brush & saw blade
Handheld Equipment	525BX	Each	\$	269.99	20.0%	\$	215.99	25.4cc pro handheld blower, 459 cfm/157mph
Handheld Equipment	543XP	Each	\$	499.99	20.0%	\$	399.99	POWERHEAD
Handheld Equipment	555	Each	\$	719.99	20.0%	\$	575.99	24", 3/8 pitch, .058 ga. 59.8cc chainsaw
Handheld Equipment	555	Each	\$	629.99	20.0%	\$	503.99	POWERHEAD
Handheld Equipment	562XP	Each	\$	749.99	20.0%	\$	599.99	18", 3/8 pitch, .050 ga. 59.8cc chainsaw
Handheld Equipment	562XP	Each	\$	749.99	20.0%	\$	599.99	18", 3/8 pitch, .058 ga. 59.8cc chainsaw
Handheld Equipment	T540XP	Each	\$	649.99	20.0%	\$	519.99	14", 3/8 pitch, .050 ga. 37.7cc top handle chainsaw
Handheld Equipment	525RJX	Each	\$	449.99	20.0%	\$	359.99	25.4cc loop handle steel drive brushcutter
Handheld Equipment	562XP	Each	\$	769.99	20.0%	\$	615.99	20", 3/8 pitch, .050 ga. 59.8cc chainsaw
Handheld Equipment	562XP	Each	\$	769.99	20.0%	\$	615.99	20", 3/8 pitch, .058 ga. 59.8cc chainsaw
Handheld Equipment	562XPG	Each	\$	779.99	20.0%	\$	623.99	POWERHEAD
Handheld Equipment	562XP	Each	\$	789.99	20.0%	\$	631.99	24", 3/8 pitch, .050 ga. 59.8cc chainsaw
Handheld Equipment	562XP	Each	\$	789.99	20.0%	\$	631.99	24", 3/8 pitch, .058 ga. 59.8cc chainsaw
Handheld Equipment	562XP	Each	\$	809.99	20.0%	\$	647.99	28", 3/8 pitch, .050 ga. 59.8cc chainsaw
Handheld Equipment	562XP	Each	\$	809.99	20.0%	\$	647.99	28", 3/8 pitch, .058 ga. 59.8cc chainsaw
Handheld Equipment	562XP	Each	\$	809.99	20.0%	\$	647.99	28", 3/8 pitch, .063 ga. 59.8cc chainsaw
Handheld Equipment	T540XP	Each	\$	679.99	20.0%	\$	543.99	16", 3/8 pitch, .050 ga. 37.7cc top handle chainsaw
Handheld Equipment	565	Each	\$	869.99	20.0%	\$	695.99	POWERHEAD

Handheld Equipment	572XPG	Each	\$ 1,029.99	20.0%	\$ 823.99	POWERHEAD
Handheld Equipment	525PT5S	Each	\$ 629.99	20.0%	\$ 503.99	25.4cc 16 foot reach telescopic professional pole saw
Handheld Equipment	562XP	Each	\$ 719.99	20.0%	\$ 575.99	POWERHEAD
Handheld Equipment	322HD60	Each	\$ 399.99	20.0%	\$ 319.99	23" double sided hedge trimmer PGE
Handheld Equipment	572XP	Each	\$ 949.99	20.0%	\$ 759.99	POWERHEAD
Handheld Equipment	555FX	Each	\$ 1,349.99	20.0%	\$1,079.99	53.3cc forestry clearing saw with XT Balance harness
Handheld Equipment	522HS75S	Each	\$ 559.99	20.0%	\$ 447.99	30" single sided coarse cut hedge trimmer pro
Handheld Equipment	522HD60S	Each	\$ 529.99	20.0%	\$ 423.99	23" double sided hedge trimmer pro
Handheld Equipment	522HDR60S	Each	\$ 529.99	20.0%	\$ 423.99	23" double sided coarse cut hedge trimmer pro
Handheld Equipment	522HDR75S	Each	\$ 559.99	20.0%	\$ 447.99	30" double sided coarse cut hedge trimmer pro
Handheld Equipment	395XP	Each	\$ 1,299.99	20.0%	\$1,039.99	32", 3/8 pitch, .050 ga. 94cc chainsaw
Handheld Equipment	395XP	Each	\$ 1,299.99	20.0%	\$1,039.99	32", 3/8 pitch, .063 ga. 94cc chainsaw
Handheld Equipment	395XP	Each	\$ 1,299.99	20.0%	\$1,039.99	32", 3/8 pitch, .058 ga. 94cc chainsaw
Handheld Equipment	395XP	Each	\$ 1,319.99	20.0%	\$1,055.99	36", 3/8 pitch, .063 ga. 94cc chainsaw
Handheld Equipment	395XP	Each	\$ 1,319.99	20.0%	\$1,055.99	36", 3/8 pitch, .058 ga. 94cc chainsaw
Handheld Equipment	395XP	Each	\$ 1,279.99	20.0%	\$1,023.99	28", 3/8 pitch, .050 ga. 94cc chainsaw
Handheld Equipment	395XP	Each	\$ 1,279.99	20.0%	\$1,023.99	28", 3/8 pitch, .058 ga. 94cc chainsaw
Handheld Equipment	395XP	Each	\$ 1,259.99	20.0%	\$1,007.99	24", 3/8 pitch, .058 ga. 94cc chainsaw
Handheld Equipment	395XP	Each	\$ 1,259.99	20.0%	\$1,007.99	24", 3/8 pitch, .050 ga. 94cc chainsaw
Handheld Equipment	395XP	Each	\$ 1,279.99	20.0%	\$1,023.99	28", 3/8 pitch, .063 ga. 94cc chainsaw
Handheld Equipment	395XP	Each	\$ 1,239.99	20.0%	\$ 991.99	20", 3/8 pitch, .058 ga. 94cc chainsaw
Handheld Equipment	395XP	Each	\$ 1,239.99	20.0%	\$ 991.99	20", 3/8 pitch, .050 ga. 94cc chainsaw
Handheld Equipment	390XP	Each	\$ 1,149.99	20.0%	\$ 919.99	POWERHEAD
Handheld Equipment	395XP	Each	\$ 1,299.99	20.0%	\$1,039.99	24", 3/8 pitch, .063 ga. 94cc chainsaw
Handheld Equipment	395XP	Each	\$ 1,199.99	20.0%	\$ 959.99	POWERHEAD
Handheld Equipment	3120XP	Each	\$ 1,849.99	20.0%	\$1,479.99	119cc chainsaw, powerhead only (.404)
Handheld Equipment	336FR	Each	\$ 599.99	20.0%	\$ 479.99	34.6cc bike handle pro brushcutter w/line, brush & saw blade
Handheld Equipment	129CD	Each	\$ 179.99	20.0%	\$ 143.99	28cc detachable, curved shaft trimmer, D attachments
Handheld Equipment	120i	Each	\$ 259.99	20.0%	\$ 207.99	14", 3/8 pitch, .043 gauge Batt Chainsaw kit w/batt & charger
Handheld Equipment	320iB	Each	\$ 229.95	20.0%	\$ 183.96	40V Li-Ion handheld blower, 412cfm/103mph kit w/batt & cger

Handheld Equipment	115IHD55	Each	\$	229.99	20.0%	\$	183.99	40v double sided battery hedge trimmer, 22" kit w/batt & charger
Handheld Equipment	115IL	Each	\$	229.99	20.0%	\$	183.99	40V straight shaft battery trimmer kit w/batt & charger
Handheld Equipment	120i	Each	\$	199.99	20.0%	\$	159.99	14", 3/8 pitch, .043 gauge Batt Chainsaw w/o batt & charger
Handheld Equipment	320IB	Each	\$	169.95	20.0%	\$	135.96	40V Li-Ion handheld blower, 412cfm/103mph, w/o batt & cger
Handheld Equipment	115IHD55	Each	\$	169.99	20.0%	\$	135.99	40v double sided battery hedge trimmer, 22" w/o batt & charger
Handheld Equipment	115IPT4	Each	\$	229.99	20.0%	\$	183.99	40v pole saw, 10" bar, w/ batt & charger
Handheld Equipment	324L	Each	\$	339.99	20.0%	\$	271.99	25cc four stroke trimmer, flex drive shaft, 1.1hp, 11.2lbs.
Handheld Equipment	322L	Each	\$	249.95	20.0%	\$	199.96	22.5cc semi professional trimmer, flex drive shaft, 1.0hp, 9.3 lbs.
Handheld Equipment	129LK	Each	\$	169.99	20.0%	\$	135.99	28cc detachable shaft trimmer, LK attachments (power head single pac)
Handheld Equipment	128CD	Each	\$	179.99	20.0%	\$	143.99	28cc detachable, curved shaft trimmer, D attachments
Handheld Equipment	150BT	Each	\$	299.99	20.0%	\$	239.99	50cc backpack blower, 2.2 hp., 434 cfm/251 mph, 22.5 lbs.
Handheld Equipment	129LK	Each	\$	229.99	20.0%	\$	183.99	28cc detachable shaft trimmer, LK attachments (single pack w. trimmer attachment)
Handheld Equipment	115IL	Each	\$	229.99	20.0%	\$	183.99	40V straight shaft battery trimmer w/o batt & charger
Handheld Equipment	350BF	Each	\$	349.99	20.0%	\$	279.99	50 cc frame throttle b/p blower, 494 cfm/180 mph, 22.5 lbs.
Handheld Equipment	435e II	Each	\$	279.99	20.0%	\$	223.99	16", .325 pitch, .050 ga. 40.9cc chainsaw fully assembled 2 pack
Handheld Equipment	435e II	Each	\$	279.99	20.0%	\$	223.99	16", .325 pitch, .050 ga. 40.9cc chainsaw fully assembled single pack
Handheld Equipment	129DIX	Each	\$	279.99	20.0%	\$	223.99	28cc detach, st.sft. trimmer, LK attachments w/blade (single pack)
Handheld Equipment	128LD	Each	\$	219.99	20.0%	\$	175.99	28cc detachable, straight shaft trimmer, D attachments
Handheld Equipment	350BT	Each	\$	349.99	20.0%	\$	279.99	50 cc tube throttle b/p blower, 494 cfm/180 mph, 22.5 lbs.
Handheld Equipment	360BT	Each	\$	449.99	20.0%	\$	359.99	65 cc tube throttle b/p blower, 632 cfm/232 mph, 23.4 lbs.

Handheld Equipment	440e II	Each	\$ 319.99	20.0%	\$ 255.99	18", .325 pitch, .050 ga. 40.9cc chainsaw fully assembled 2 pack
Handheld Equipment	440e II	Each	\$ 319.99	20.0%	\$ 255.99	16", .325 pitch, .050 ga. 40.9cc fully assembled saw
Handheld Equipment	450e II	Each	\$ 399.99	20.0%	\$ 319.99	18", .325 pitch, .050 ga. 50.2cc chainsaw fully assembled, single pack in POWERBOX
Handheld Equipment	445e II	Each	\$ 359.99	20.0%	\$ 287.99	16", .325 pitch, .050 ga. 50.2cc chainsaw fully assembled, single pack
Handheld Equipment	445e II	Each	\$ 359.99	20.0%	\$ 287.99	16", .325 pitch, .050 ga. 50.2cc chainsaw, single pre-pack
Handheld Equipment	445e II	Each	\$ 369.99	20.0%	\$ 295.99	18", .325 pitch, .050 ga. 50.2cc chainsaw fully assembled, single pack
Handheld Equipment	445e II	Each	\$ 369.99	20.0%	\$ 295.99	18", .325 pitch, .050 ga. 50.2cc chainsaw, single pre-pack
Handheld Equipment	450e II	Each	\$ 379.99	20.0%	\$ 303.99	18", .325 pitch, .050 ga. 50.2cc chainsaw fully assembled, single pack
Handheld Equipment	450e II	Each	\$ 379.99	20.0%	\$ 303.99	18", .325 pitch, .050 ga. 50.2cc chainsaw, single pre-pack
Handheld Equipment	445e II	Each	\$ 369.99	20.0%	\$ 295.99	18", .325 pitch, .050 ga. 50.2cc chainsaw fully assembled, twin pack
Handheld Equipment	455 RANCHER	Each	\$ 459.99	20.0%	\$ 367.99	18", 3/8 pitch, .050 ga. 55.5cc Rancher chainsaw, assembled
Handheld Equipment	450e Rancher II	Each	\$ 399.99	20.0%	\$ 319.99	20", .325 pitch, .050 ga. 50.2cc saw, assembled, FT bar, 2 pack
Handheld Equipment	455 RANCHER	Each	\$ 469.99	20.0%	\$ 375.99	20", 3/8 pitch, .050 ga. 55.5cc Rancher chainsaw, assembled, 2 pack
Handheld Equipment	455 RANCHER	Each	\$ 459.99	20.0%	\$ 367.99	18", 3/8 pitch, .050 ga. 55.5cc Rancher
Handheld Equipment	455 RANCHER	Each	\$ 469.99	20.0%	\$ 375.99	20", 3/8 pitch, .050 ga. 55.5cc Rancher chainsaw, assembled
Handheld Equipment	455 RANCHER	Each	\$ 459.99	20.0%	\$ 367.99	18", 3/8 pitch, .058 ga. 55.5cc Rancher
Handheld Equipment	450e II	Each	\$ 399.99	20.0%	\$ 319.99	20", .325 pitch, .050 ga. 50.2cc chainsaw, single pre-pack
Handheld Equipment	455 RANCHER	Each	\$ 469.99	20.0%	\$ 375.99	20", 3/8 pitch, .050 ga. 55.5cc Rancher
Handheld Equipment	455 RANCHER	Each	\$ 469.99	20.0%	\$ 375.99	20", 3/8 pitch, .058 ga. 55.5cc Rancher
Handheld Equipment	460 RANCHER	Each	\$ 539.99	20.0%	\$ 431.99	24", 3/8 pitch, .050 ga. 60.3cc Rancher
Handheld Equipment	460 RANCHER	Each	\$ 539.99	20.0%	\$ 431.99	24", 3/8 pitch, .050 ga. 60.3cc Rancher chainsaw, assembled
Handheld Equipment	460 RANCHER	Each	\$ 519.99	20.0%	\$ 415.99	18", 3/8 pitch, .050 ga. 60.3cc Rancher

Handheld Equipment	115IPT4	Each	\$ 169.99	20.0%	\$ 135.99	40v pole saw, 10" bar, w/o batt & charger
Handheld Equipment	460 RANCHER	Each	\$ 519.99	20.0%	\$ 415.99	18", 3/8 pitch, .058 ga. 60.3cc Rancher
Handheld Equipment	460 RANCHER	Each	\$ 529.99	20.0%	\$ 423.99	20", 3/8 pitch, .050 ga. 60.3cc Rancher
Handheld Equipment	460 RANCHER	Each	\$ 529.99	20.0%	\$ 423.99	20", 3/8 pitch, .058 ga. 60.3cc Rancher
Handheld Equipment	125BVX	Each	\$ 199.99	20.0%	\$ 159.99	28 cc handheld blower with vac kit, 1.1 hp., 425 cfm/170 mph
Robotic Mowers	550	Each	\$ 3,499.99	10.0%	\$3,149.99	Robotic mower, 1.25 acre capacity, Professional, Husqvarna Fleet System included (+Automower Connect), GPS navi, x3 Guide wires, Penta search, Weather timer, Professional Control, Terrain wheels, 2.4" cut
Robotic Mowers	550H	Each	\$ 3,499.99	10.0%	\$3,149.99	Robotic mower, 1.25 acre capacity, Professional, Husqvarna Fleet System included (+Automower Connect), GPS navi, x3 Guide wires, Penta search, Weather timer, Professional Control, Terrain wheels, 3.6" cut
Robotic Mowers	450X	Each	\$ 3,499.99	10.0%	\$3,149.99	Robotic mower, 1.25 acre capacity, X-line feature package (Automower Connect, GPS navi, LED lights), x3 Guide wires, Penta search, Weather timer, 2.4" cut height, No factory PIN code
Robotic Mowers	450XH	Each	\$ 3,499.99	10.0%	\$3,149.99	Robotic mower, 1.25 acre capacity, X-line feature package (Automower Connect, GPS navi, LED lights), x3 Guide wires, Penta search, Weather timer, 3.6" cut height, No factory PIN code
Robotic Mowers	430X	Each	\$ 2,699.99	10.0%	\$2,429.99	Robotic mower, 0.8 acre capacity, X-line feature package (Automower Connect, GPS navi, LED lights), x2 Guide wires, Quad search, Weather timer, 2.4" cut height, No factory PIN
Robotic Mowers	430XH	Each	\$ 2,699.99	10.0%	\$2,429.99	Robotic mower, 0.8 acre capacity, X-line feature package (Automower Connect, GPS navi, LED lights), x2 Guide wires, Quad search, Weather timer, 3.6" cut height, No factory PIN
Robotic Mowers	315X	Each	\$ 1,999.99	10.0%	\$1,799.99	Robotic mower, 0.4 acre capacity, X-line feature package (Automower Connect, GPS navi, LED lights), x1 Guide wire, Triple search, Weather timer, 2.4" cut height, No factory PIN

Attachments/ Accessories	QC330	Each	\$ 99.99	15.0%	\$ 84.99	330W Quick Charge battery charger
Attachments/ Accessories	BLI950X	Each	\$ 949.99	15.0%	\$ 807.49	40V Li-Ion battery backpack, 31.1Ah, 1120W
Attachments/ Accessories	VI600F	Each	\$ 229.99	15.0%	\$ 195.49	Voltage Inverter for in field battery charging using standard plug
Attachments/ Accessories	VI600F	Each	\$ 229.99	15.0%	\$ 195.49	Voltage Inverter for in field battery charging using standard plug
Attachments/ Accessories	SR600-2	Each	\$ 319.99	15.0%	\$ 271.99	DX SWEEPER ATTACHMENT (solid shaft)
Attachments/ Accessories	SR600-2	Each	\$ 319.99	15.0%	\$ 271.99	DX SWEEPER ATTACHMENT (solid shaft)
Attachments/ Accessories	DT600	Each	\$ 299.99	15.0%	\$ 254.99	DX Dethatcher Attachment (solid shaft)
Attachments/ Accessories	DT600	Each	\$ 299.99	15.0%	\$ 254.99	DX Dethatcher Attachment (solid shaft)
Attachments/ Accessories	BLI300	Each	\$ 299.99	15.0%	\$ 254.99	40V Li-Ion professional battery, 9Ah, 324W
Attachments/ Accessories	BR600	Each	\$ 279.99	15.0%	\$ 237.99	DX Bristle Brush Attachment (solid shaft)
Attachments/ Accessories	BR600	Each	\$ 279.99	15.0%	\$ 237.99	DX Bristle Brush Attachment (solid shaft)
Attachments/ Accessories	BLI20	Each	\$ 149.99	15.0%	\$ 127.49	40V Li-Ion homeowner battery, 4.0Ah, 144W
Attachments/ Accessories	CA230	Each	\$ 199.99	15.0%	\$ 169.99	LK CULTIVATOR ATTACHMENT (solid shaft)
Attachments/ Accessories	CA230	Each	\$ 199.99	15.0%	\$ 169.99	LK CULTIVATOR ATTACHMENT (solid shaft)
Attachments/ Accessories	BLI200	Each	\$ 199.99	15.0%	\$ 169.99	40V Li-Ion professional battery, 5Ah, 180W
Attachments/ Accessories	BA101	Each	\$ 129.99	15.0%	\$ 110.49	LK Blower Attachment, 530cfm, 148mph (solid shaft)
Attachments/ Accessories	BA101	Each	\$ 129.99	15.0%	\$ 110.49	LK Blower Attachment, 530cfm, 148mph (solid shaft)
Attachments/ Accessories	BLI100	Each	\$ 129.99	15.0%	\$ 110.49	40V Li-Ion professional battery, 2.5Ah, 90W
Attachments/ Accessories	Battery Belt	Each	\$ 139.99	15.0%	\$ 118.99	Connector kit, including belt, Bli carrier w. connector, accessory bag
Attachments/ Accessories	HA110	Each	\$ 259.99	15.0%	\$ 220.99	DX HEDGETRIMMER ATTACHMENT 4" BOOM (solid shaft)
Attachments/ Accessories	HA110	Each	\$ 259.99	15.0%	\$ 220.99	DX HEDGETRIMMER ATTACHMENT 4" BOOM (solid shaft)
Attachments/ Accessories	EX780	Each	\$ 69.99	15.0%	\$ 59.49	DX Extension Attachment (solid shaft)
Attachments/ Accessories	EX780	Each	\$ 69.99	15.0%	\$ 59.49	DX Extension Attachment (solid shaft)
Attachments/ Accessories	HA850	Each	\$ 279.99	15.0%	\$ 237.99	DX HEDGETRIMMER ATTACHMENT 33" BOOM (solid shaft)
Attachments/ Accessories	HA850	Each	\$ 279.99	15.0%	\$ 237.99	DX HEDGETRIMMER ATTACHMENT 33" BOOM (solid shaft)
Attachments/ Accessories	QC80F	Each	\$ 59.99	15.0%	\$ 50.99	Battery charger for in vehicle charging using 12 volt port

Attachments/ Accessories	QC80F	Each	\$	59.99	15.0%	\$	50.99	Battery charger for in vehicle charging using 12 volt port
Attachments/ Accessories	BCA850	Each	\$	99.99	15.0%	\$	84.99	LK Brushcutter Attachment (solid shaft)
Attachments/ Accessories	PA1100	Each	\$	209.99	15.0%	\$	178.49	DX POLE SAW ATTACHMENT 43" BOOM (solid shaft)
Attachments/ Accessories	PA1100	Each	\$	219.99	15.0%	\$	186.99	DX POLE SAW ATTACHMENT 43" BOOM (solid shaft)
Attachments/ Accessories	Top Cover Gray (Fits 315X)	Each	\$	39.99	15.0%	\$	33.99	Automower Accessories
Attachments/ Accessories	Top Cover White (Fits AUTOMOWER CONNECT 2G/3G (Fits 300, 400, 500 SERIES)	Each	\$	79.99	15.0%	\$	67.99	Automower Accessories
Attachments/ Accessories	SIGNAL BOOSTER (Fits 220AC, 230ACX)	Each	\$	249.99	15.0%	\$	212.49	Automower Accessories
Attachments/ Accessories	4 Gallon Backpack Sprayer	Each	\$	109.99	15.0%	\$	93.49	Sprayer
Attachments/ Accessories	Twin Bagger, 42" Stamped Tractor	Each	\$	329.00	15.0%	\$	279.65	Tractor Baggers
Attachments/ Accessories	Triple Bagger, 42" Stamped Tractor	Each	\$	449.00	15.0%	\$	381.65	Tractor Baggers
Attachments/ Accessories	Twin Bagger, 46" Stamped Tractor	Each	\$	329.00	15.0%	\$	279.65	Tractor Baggers
Attachments/ Accessories	Triple Bagger, 46"/48" Stamped	Each	\$	449.00	15.0%	\$	381.65	Tractor Baggers
Attachments/ Accessories	Triple Bagger 48" Stamped, GT frame	Each	\$	449.00	15.0%	\$	381.65	Tractor Baggers

Attachments/ Accessories	Triple Bagger, 54" Stamped Tractor	Each	\$ 349.00	15.0%	\$ 296.65	Tractor Baggers
Attachments/ Accessories	Twin Bagger w/ Blower 42/ 48" Estate Fab tractor	Each	\$ 899.00	15.0%	\$ 764.15	Tractor Baggers
Attachments/ Accessories	Twin Bagger w/ Blower 52" Estate Fab tractor	Each	\$ 899.00	15.0%	\$ 764.15	Tractor Baggers
Attachments/ Accessories	Twin Bagger, 42" ClearCut Tractor	Each	\$ 399.00	15.0%	\$ 339.15	Tractor Baggers
Attachments/ Accessories	Triple bagger, 48" ClearCut Tractor	Each	\$ 449.00	15.0%	\$ 381.65	Tractor Baggers
Attachments/ Accessories	Triple bagger, 54" ClearCut Tractor	Each	\$ 449.00	15.0%	\$ 381.65	Tractor Baggers
Attachments/ Accessories	Twin Bagger, 42" Stamped Zero Turn Z142	Each	\$ 349.00	15.0%	\$ 296.65	Zero Turn Baggers
Attachments/ Accessories	Twin Bagger, 46" Stamped Zero Turn Z200 RZ	Each	\$ 499.00	15.0%	\$ 424.15	Zero Turn Baggers
Attachments/ Accessories	Triple Bagger, 54" Stamped Zero Z200 RZ54	Each	\$ 549.00	15.0%	\$ 466.65	Zero Turn Baggers
Attachments/ Accessories	Triple Bagger, 54" Stamped Zero MZ5424	Each	\$ 549.00	15.0%	\$ 466.65	Zero Turn Baggers
Attachments/ Accessories	Triple Bagger w/blower 48" Estate Fab, Zero Turn Z200/RZ	Each	\$ 1,099.00	15.0%	\$ 934.15	Zero Turn Baggers

Attachments/ Accessories	Triple Bagger w/ Blower 52" MZ zero turn	Each	\$ 1,099.00	15.0%	\$ 934.15	Zero Turn Baggers
Attachments/ Accessories	Triple Bagger w/Blower 61" MZ Zero Turn	Each	\$ 1,099.00	15.0%	\$ 934.15	Zero Turn Baggers
Attachments/ Accessories	Twin Bagger, 42" ClearCut Zero Turn	Each	\$ 499.00	15.0%	\$ 424.15	Zero Turn Baggers
Attachments/ Accessories	Twin Bagger, 42" ClearCut 42" Z200	Each	\$ 499.00	15.0%	\$ 424.15	Zero Turn Baggers
Attachments/ Accessories	Triple bagger, 48" ClearCut Zero Turn MZ48	Each	\$ 499.00	15.0%	\$ 424.15	Zero Turn Baggers
Attachments/ Accessories	Triple Bagger 48" ClearCut, Zero Turn Z200	Each	\$ 499.00	15.0%	\$ 424.15	Zero Turn Baggers
Attachments/ Accessories	Triple bagger, 54" ClearCut Z200	Each	\$ 499.00	15.0%	\$ 424.15	Zero Turn Baggers
Attachments/ Accessories	Triple bagger, 54" ClearCut MZ54	Each	\$ 499.00	15.0%	\$ 424.15	Zero Turn Baggers
Attachments/ Accessories	Z400 60/54 Commercial OCDC and Z500 60/54	Each	\$ 299.00	15.0%	\$ 254.15	Zero Turn Baggers
Attachments/ Accessories	Z400 60/54 Collection: 3 Bin /9 bushel	Each	\$ 1,899.00	15.0%	\$1,614.15	Zero Turn Baggers
Attachments/ Accessories	Z400 48 Clear Cut Collection: 3 Bin / 9	Each	\$ 1,099.00	15.0%	\$ 934.15	Zero Turn Baggers
Attachments/ Accessories	Z400 54 Clear Cut Collection	Each	\$ 1,099.00	15.0%	\$ 934.15	Zero Turn Baggers

Attachments/ Accessories	Z560X / Z560 / Z554X / Z554 / PZT48 / PZT54 / PZT60 Collection: 9 Bushel	Each	\$ 2,399.00	15.0%	\$2,039.15	Zero Turn Baggers
Attachments/ Accessories	Z560X / PZ60 / PZ54 Collection: 13 Bushel	Each	\$ 2,499.00	15.0%	\$2,124.15	Zero Turn Baggers
Attachments/ Accessories	Z560X / Z560 / Z554X / Z554 / PZ54 / PZ60 Collection: 11 Bushel	Each	\$ 3,199.00	15.0%	\$2,719.15	Zero Turn Baggers
Attachments/ Accessories	M-ZT 52 Collection	Each	\$ 1,399.00	15.0%	\$1,189.15	Zero Turn Baggers
Attachments/ Accessories	M-ZT 61 Collection	Each	\$ 1,399.00	15.0%	\$1,189.15	Zero Turn Baggers
Attachments/ Accessories	P-ZT 48, 54, 60 P-ZT Collection : 8 bushel	Each	\$ 2,799.00	15.0%	\$2,379.15	Zero Turn Baggers
Attachments/ Accessories	V548 / V554 OCDC	Each	\$ 199.00	15.0%	\$ 169.15	Zero Turn Baggers
Attachments/ Accessories	V548 / V554 Collection	Each	\$ 329.00	15.0%	\$ 279.65	Zero Turn Baggers
Attachments/ Accessories	Mulch Kit, 42" Stamped	Each	\$ 49.99	15.0%	\$ 42.49	Mulch Kits
Attachments/ Accessories	Mulch Kit, 42" Stamped	Each	\$ 49.99	15.0%	\$ 42.49	Mulch Kits
Attachments/ Accessories	Mulch Kit 46" Stamped	Each	\$ 54.99	15.0%	\$ 46.74	Mulch Kits
Attachments/ Accessories	Mulch Kit 46" Stamped	Each	\$ 49.99	15.0%	\$ 42.49	Mulch Kits
Attachments/ Accessories	Mulch Kit 48" Stamped	Each	\$ 54.99	15.0%	\$ 46.74	Mulch Kits
Attachments/ Accessories	Mulch Kit 54" Stamped	Each	\$ 64.99	15.0%	\$ 55.24	Mulch Kits
Attachments/ Accessories	Mulch Kit 54" Stamped (OFP)	Each	\$ 69.99	15.0%	\$ 59.49	Mulch Kits

Attachments/ Accessories	Mulch Kit, 42" ClearCut™	Each	\$	54.99	15.0%	\$	46.74	Mulch Kits
Attachments/ Accessories	Mulch Kit, 48" ClearCut™ (Z200 and	Each	\$	69.99	15.0%	\$	59.49	Mulch Kits
Attachments/ Accessories	Mulch Kit, 54" ClearCut™	Each	\$	59.99	15.0%	\$	50.99	Mulch Kits
Attachments/ Accessories	Mulch Kit, 42" Estate Fab deck (3 Bld)	Each	\$	139.99	15.0%	\$	118.99	Mulch Kits
Attachments/ Accessories	Mulch Kit, 48" Estate Fab deck	Each	\$	179.99	15.0%	\$	152.99	Mulch Kits
Attachments/ Accessories	Mulch Kit 52" Estate Fab Deck Tractor	Each	\$	169.99	15.0%	\$	144.49	Mulch Kits
Attachments/ Accessories	Mulch Kit 54" Clear Cut Mulch Kit: MZ54	Each	\$	59.99	15.0%	\$	50.99	Mulch Kits
Attachments/ Accessories	Mulch Kit 48" Clear Cut Mulch kit: MZ48	Each	\$	64.99	15.0%	\$	55.24	Mulch Kits
Attachments/ Accessories	Mulch Kit 54": Z400/Z500	Each	\$	279.00	15.0%	\$	237.15	Mulch Kits
Attachments/ Accessories	Mulch Kit 60": Z400/Z500	Each	\$	279.00	15.0%	\$	237.15	Mulch Kits
Attachments/ Accessories	Mulch Kit 54": Z554 / Z554X	Each	\$	279.00	15.0%	\$	237.15	Mulch Kits
Attachments/ Accessories	Mulch Kit 60": Z560X / Z560	Each	\$	279.00	15.0%	\$	237.15	Mulch Kits
Attachments/ Accessories	Mulch Kit 72": Z572X	Each	\$	299.00	15.0%	\$	254.15	Mulch Kits
Attachments/ Accessories	Mulch Kit 52": M-ZT 52	Each	\$	199.00	15.0%	\$	169.15	Mulch Kits
Attachments/ Accessories	Mulch Kit 61": M-ZT 61	Each	\$	169.99	15.0%	\$	144.49	Mulch Kits
Attachments/ Accessories	Mulch Kit 48" :V500	Each	\$	149.99	15.0%	\$	127.49	Mulch Kits
Attachments/ Accessories	Mulch Kit 54" :V500	Each	\$	159.99	15.0%	\$	135.99	Mulch Kits

Attachments/ Accessories	PZ / P-ZT / Z560X / Z560 / Z554X/ Z555 54" / 60" Drive Kit	Each	\$ 149.99	15.0%	\$ 127.49	Drive Kits / Grass Blower Assembly (Zero Turn Mowers)
Attachments/ Accessories	PZ-T / Z548 / CZT48X 48" (Serial Numbers 100112 and higher)	Each	\$ 159.99	15.0%	\$ 135.99	Drive Kits / Grass Blower Assembly (Zero Turn Mowers)
Attachments/ Accessories	Z400 60" Drive Kit	Each	\$ 149.99	15.0%	\$ 127.49	Drive Kits / Grass Blower Assembly (Zero Turn Mowers)
Attachments/ Accessories	Z400 54" Drive Kit	Each	\$ 149.99	15.0%	\$ 127.49	Drive Kits / Grass Blower Assembly (Zero Turn Mowers)
Attachments/ Accessories	PZ / P-ZT Grass Blower Assembly: 54" / 60"	Each	\$ 899.00	15.0%	\$ 764.15	Drive Kits / Grass Blower Assembly (Zero Turn Mowers)
Attachments/ Accessories	MZ / MZ-T Grass Blower Assembly: 54" / 60"	Each	\$ 749.00	15.0%	\$ 636.65	Drive Kits / Grass Blower Assembly (Zero Turn Mowers)
Attachments/ Accessories	Arm Rest Kit : RZ series	Each	\$ 49.99	15.0%	\$ 42.49	Arm Rests, Light Kits, Seats, Hitch Kits (Zero Turn Mowers)
Attachments/ Accessories	Battery Charger	Each	\$ 49.99	15.0%	\$ 42.49	Arm Rests, Light Kits, Seats, Hitch Kits (Zero Turn Mowers)
Attachments/ Accessories	Light Kit	Each	\$ 139.99	15.0%	\$ 118.99	Arm Rests, Light Kits, Seats, Hitch Kits (Zero Turn Mowers)
Attachments/ Accessories	Light Kit	Each	\$ 99.99	15.0%	\$ 84.99	Arm Rests, Light Kits, Seats, Hitch Kits (Zero Turn Mowers)
Attachments/ Accessories	Light Kit (ROPS)	Each	\$ 139.99	15.0%	\$ 118.99	Arm Rests, Light Kits, Seats, Hitch Kits (Zero Turn Mowers)
Attachments/ Accessories	Premium Suspension Seat (Seats Inc)	Each	\$ 549.00	15.0%	\$ 466.65	Arm Rests, Light Kits, Seats, Hitch Kits (Zero Turn Mowers)
Attachments/ Accessories	Roll Over Protection	Each	\$ 449.00	15.0%	\$ 381.65	Arm Rests, Light Kits, Seats, Hitch Kits (Zero Turn Mowers)
Attachments/ Accessories	Hitch Kit : RZ / Z200	Each	\$ 24.99	15.0%	\$ 21.24	Arm Rests, Light Kits, Seats, Hitch Kits (Zero Turn Mowers)

Attachments/ Accessories	Hitch Kit : MZ series	Each	\$	24.99	15.0%	\$	21.24	Arm Rests, Light Kits, Seats, Hitch Kits (Zero Turn Mowers)
Attachments/ Accessories	Tractor Cover	Each	\$	84.00	15.0%	\$	71.40	Covers and Shades
Attachments/ Accessories	Tractor Seat Cover	Each	\$	39.99	15.0%	\$	33.99	Covers and Shades
Attachments/ Accessories	Tractor Seat Cover w/ Armrest Holes	Each	\$	39.99	15.0%	\$	33.99	Covers and Shades
Attachments/ Accessories	Tractor Sun Shade	Each	\$	149.99	15.0%	\$	127.49	Covers and Shades
Attachments/ Accessories	Zero-Turn Mower Cover, up to 54" deck	Each	\$	84.00	15.0%	\$	71.40	Covers and Shades
Attachments/ Accessories	Zero-Turn Sun Shade	Each	\$	149.99	15.0%	\$	127.49	Covers and Shades
Attachments/ Accessories	48" Snow Blade	Each	\$	399.00	15.0%	\$	339.15	Snow Blades
Attachments/ Accessories	50" 2-Stage Snow Thrower with Electric Lift	Each	\$	2,199.00	15.0%	\$	\$1,869.15	2-Stage Snow Thrower Attachments
Attachments/ Accessories	42" 2-Stage Snow Thrower (Electric Lift)	Each	\$	1,899.00	15.0%	\$	\$1,614.15	2-Stage Snow Thrower Attachments
Attachments/ Accessories	42" 2-Stage Snow Thrower (Manual Lift)	Each	\$	1,599.00	15.0%	\$	\$1,359.15	2-Stage Snow Thrower Attachments
Attachments/ Accessories	Weight Bracket and weight (TA321)	Each	\$	149.99	15.0%	\$	127.49	Wheel Weights
Attachments/ Accessories	Wheel Weights One pair (62 lbs.)	Each	\$	89.99	15.0%	\$	76.49	Wheel Weights
Attachments/ Accessories	Wheel Weights One individual weight (50 lbs. each)	Each	\$	69.99	15.0%	\$	59.49	Wheel Weights
Attachments/ Accessories	18" x 9.5" x 8"	Each	\$	99.99	15.0%	\$	84.99	Tire Chains
Attachments/ Accessories	20" x 8" x 8"	Each	\$	99.99	15.0%	\$	84.99	Tire Chains
Attachments/ Accessories	20" x 10" x 8"	Each	\$	99.99	15.0%	\$	84.99	Tire Chains

Attachments/ Accessories	22" x 9.5" x 12"	Each	\$ 99.99	15.0%	\$ 84.99	Tire Chains
Attachments/ Accessories	23" x 10.5" x	Each	\$ 99.99	15.0%	\$ 84.99	Tire Chains
Attachments/ Accessories	Tractor Snow Cab (4-sided)	Each	\$ 329.00	15.0%	\$ 279.65	Tractor Snow Cab
Attachments/ Accessories	2,000 lb. Loading Ramps	Each	\$ 219.00	15.0%	\$ 186.15	Loading Ramps
Attachments/ Accessories	Tractor Lift	Each	\$ 219.00	15.0%	\$ 186.15	Tractor Lift
Attachments/ Accessories	Tractor Bumper Kit	Each	\$ 54.99	15.0%	\$ 46.74	Tractor Bumper and Brush Guard
Attachments/ Accessories	LS Brush Guard	Each	\$ 89.99	15.0%	\$ 76.49	Tractor Bumper and Brush Guard
Specialty Turf Equipment	SG13	Each	\$ 4,699.95	20.0%	\$3,759.96	Stump Grinder Honda GX390 11.7 HP
Specialty Turf Equipment	TA48	Each	\$ 1,849.95	20.0%	\$1,479.96	48" Trip Aire Towable Aerator
Specialty Turf Equipment	DT18	Each	\$ 1,524.95	20.0%	\$1,219.96	18" Power Rake, Flail Briggs & Stratton 900 Series 9.0 GT
Specialty Turf Equipment	SC18	Each	\$ 4,899.95	20.0%	\$3,919.96	18" Sod Cutter Honda GX160 4.8 HP
Specialty Turf Equipment	DT22	Each	\$ 1,624.95	20.0%	\$1,299.96	22" Power Rake, Flail Briggs & Stratton 900 Series 9.0 GT
Specialty Turf Equipment	AR25	Each	\$ 3,899.95	20.0%	\$3,119.96	25.5" Aerator Honda GX120 3.5 HP
Specialty Turf Equipment	DT22H	Each	\$ 1,849.95	20.0%	\$1,479.96	22" Power Rake, Flail Honda GX160 4.8 HP
Specialty Turf Equipment	DT22H	Each	\$ 1,624.95	20.0%	\$1,299.96	22" Power Rake, NO REEL Honda GX160 4.8 HP
Specialty Turf Equipment	SD22	Each	\$ 1,949.95	20.0%	\$1,559.96	22" Seeder Briggs & Stratton 900 Series 9.0 GT
Specialty Turf Equipment	AR19H	Each	\$ 3,299.95	20.0%	\$2,639.96	19" Aerator Honda GX120 3.5 HP
Specialty Turf Equipment	BE650	Each	\$ 3,499.95	20.0%	\$2,799.96	BE650 Bed Edger Honda GX200 5.5 HP
Specialty Turf Equipment	SD22H	Each	\$ 2,174.95	20.0%	\$1,739.96	22" Seeder Honda GX160 4.8 HP
Specialty Turf Equipment	AR19	Each	\$ 3,099.95	20.0%	\$2,479.96	19" Aerator, Briggs & Stratton 900 Series 9.0
Snow Equipment	ST124	Each	\$ 699.99	20.0%	\$ 559.99	24" / Dual Stage / 212cc
Snow Equipment	ST 327	Each	\$ 1,399.99	20.0%	\$1,119.99	27" / Power Steering / Dual Stage / Heated Grips / Friction Disc Transmission / 291cc

Husqvarna Services

Installation of 315X Automower	\$ 550.00	No Discount
Installation of 430X/430XH Automower	\$ 675.00	No Discount
Installation of 450X/450XH Automower	\$ 1,050.00	No Discount
No Discount	No Discount	No Discount



Association of Educational
PURCHASING AGENCIES

Acceptance of Bid & Contract Award

Instructions: PART I of this form is to be completed by the Bidder and signed by its Authorized Representative. PART II will be completed by the AEPA Member Agency only upon the occasion of the bid award. If approved by AEPA, the Bidder is required to produce a copy of the document for each of the AEPA Member Agency with which it contracts.

PART I: BIDDER

In compliance with the Invitation for Bid (IFB), the undersigned warrants that I/we have examined all Instructions to Bidders, associated documents, and being familiar with all of the conditions of the bid, hereby offer and agree to furnish all labor, materials, supplies and equipment incurred in compliance with all terms, conditions, specifications and amendments associated with this IFB and any written exceptions to the bid. Signature also certifies understanding and compliance with the certification requirements of the AEPA Member Agency's Terms and Conditions and/or Special Terms and Conditions. The undersigned understands that their competence, ability, capacity and obligations to offer and provide the proposed tangible personal property, professional services, construction services and other services on behalf of the Bidder Partner as well as other factors of interest to the AEPA Member Agency as stated in the evaluation section, will be a consideration in making the award.

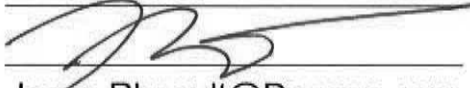
Business Name	Clark Equipment Company dba Bobcat Company	Date	9/12/2019
Address	250 East Beaton Dr.	City, State Zip	West Fargo, ND 58078
Contact Person	Jesse Rheault	Title	Government Account Manager
Authorized Signature		Title	Government Account Manager
Email	Jesse.Rheault@Doosan.com	Phone	701-630-5134

PART II: AWARDING MEMBER AGENCY

Your bid response for the above identified bid is hereby accepted. As a Bidder Partner you are now bound to offer and provide the products and services identified within this IFB, your response and approved by AEPA, including all terms, conditions, specifications, exceptions and amendments. As Bidder Partner, you are hereby not to commence any billable work or provide any products or services under this contract until an executed purchase order is received from the AEPA Member Agency or Participating Entities. The intent of this contract is to constitute the final and complete agreement between the AEPA Member Agency and Bidder Partner, and no other agreements, oral or otherwise, regarding the subject matter of this contract, shall bind any of the parties hereto. No change or modification of this contract shall be valid unless in writing and signed by both parties to this contract. If any provision of this contract is deemed invalid or illegal by any appropriate court of law, the remainder of this contract shall not be affected thereby. The initial term of this contract shall be for up to fifteen (15) months and will commence on the date indicated below and continue until February 28, 2021, unless terminated, canceled or extended. By mutual written agreement as warranted, the contract may be extended month by month up to six (6) months or for three (3) additional 12-month periods.

Awarding Agency	Cooperative Purchasing Connection [Minnesota/South Dakota]		
Authorized Representative	Jane Eastes, Deputy Director	DocuSigned by:	Jane Eastes
Awarded this	15th	day of	January 2020
Contract to commence			Contract number 020-E
(Member Agency to select)	January 15, 2020	Or	March 1, 2020



Association of Educational
PURCHASING AGENCIES

Acceptance of Bid & Contract Award

Instructions: PART I of this form is to be completed by the Bidder and signed by its Authorized Representative. PART II will be completed by the AEPA Member Agency only upon the occasion of the bid award. If approved by AEPA, the Bidder is required to produce a copy of the document for each of the AEPA Member Agency with which it contracts.

PART I: BIDDER

In compliance with the Invitation for Bid (IFB), the undersigned warrants that I/we have examined all Instructions to Bidders, associated documents, and being familiar with all of the conditions of the bid, hereby offer and agree to furnish all labor, materials, supplies and equipment incurred in compliance with all terms, conditions, specifications and amendments associated with this IFB and any written exceptions to the bid. Signature also certifies understanding and compliance with the certification requirements of the AEPA Member Agency's Terms and Conditions and/or Special Terms and Conditions. The undersigned understands that their competence, ability, capacity and obligations to offer and provide the proposed tangible personal property, professional services, construction services and other services on behalf of the Bidder Partner as well as other factors of interest to the AEPA Member Agency as stated in the evaluation section, will be a consideration in making the award.

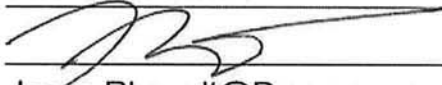
Business Name	<u>Clark Equipment Company dba Bobcat Company</u>	Date	<u>9/12/2019</u>
Address	<u>250 East Beaton Dr.</u>	City, State Zip	<u>West Fargo, ND 58078</u>
Contact Person	<u>Jesse Rheault</u>	Title	<u>Government Account Manager</u>
Authorized Signature		Title	<u>Government Account Manager</u>
Email	<u>Jesse.Rheault@Doosan.com</u>	Phone	<u>701-630-5134</u>

PART II: AWARDING MEMBER AGENCY

Your bid response for the above identified bid is hereby accepted. As a Bidder Partner you are now bound to offer and provide the products and services identified within this IFB, your response and approved by AEPA, including all terms, conditions, specifications, exceptions and amendments. As Bidder Partner, you are hereby not to commence any billable work or provide any products or services under this contract until an executed purchase order is received from the AEPA Member Agency or Participating Entities. The intent of this contract is to constitute the final and complete agreement between the AEPA Member Agency and Bidder Partner, and no other agreements, oral or otherwise, regarding the subject matter of this contract, shall bind any of the parties hereto. No change or modification of this contract shall be valid unless in writing and signed by both parties to this contract. If any provision of this contract is deemed invalid or illegal by any appropriate court of law, the remainder of this contract shall not be affected thereby. The initial term of this contract shall be for up to fifteen (15) months and will commence on the date indicated below and continue until February 28, 2021, unless terminated, canceled or extended. By mutual written agreement as warranted, the contract may be extended month by month up to six (6) months or for three (3) additional 12-month periods.

Awarding Agency	<u>North Dakota Educators Service Cooperative</u>		
Authorized Representative	<u>Rodney Scherbenske, Board President</u>		
Awarded this	<u>15th</u>	day of	<u>January 2020</u>
Contract to commence		Contract Number	<u>020-E</u>
(Member Agency to select)	<u>January 15, 2020</u>	Or	March 1, 2020



Association of Educational
PURCHASING AGENCIES

Acceptance of Bid & Contract Award

Instructions: PART I of this form is to be completed by the Bidder and signed by its Authorized Representative. PART II will be completed by the AEPA Member Agency only upon the occasion of the bid award. If approved by AEPA, the Bidder is required to produce a copy of the document for each of the AEPA Member Agency with which it contracts.

PART I: BIDDER

In compliance with the Invitation for Bid (IFB), the undersigned warrants that I/we have examined all Instructions to Bidders, associated documents, and being familiar with all of the conditions of the bid, hereby offer and agree to furnish all labor, materials, supplies and equipment incurred in compliance with all terms, conditions, specifications and amendments associated with this IFB and any written exceptions to the bid. Signature also certifies understanding and compliance with the certification requirements of the AEPA Member Agency's Terms and Conditions and/or Special Terms and Conditions. The undersigned understands that their competence, ability, capacity and obligations to offer and provide the proposed tangible personal property, professional services, construction services and other services on behalf of the Bidder Partner as well as other factors of interest to the AEPA Member Agency as stated in the evaluation section, will be a consideration in making the award.

Business Name	<u>Husqvarna Professional Products</u>	Date	<u>9/12/2019</u>
Address	<u>9335 Harris Corners Pkwy #500</u>	City, State Zip	<u>Charlotte, NC, 28269</u>
Contact Person	<u>Jacob Breig</u>	Title	<u>Government Sales Manager</u>
Authorized Signature	<u>[Signature]</u>	Title	<u>VP Sales VP</u>
Email	<u>jake.breig@husqvarnagroup.com</u>	Phone	<u>704-340-1367</u>

PART II: AWARDING MEMBER AGENCY

Your bid response for the above identified bid is hereby accepted. As a Bidder Partner you are now bound to offer and provide the products and services identified within this IFB, your response and approved by AEPA, including all terms, conditions, specifications, exceptions and amendments. As Bidder Partner, you are hereby not to commence any billable work or provide any products or services under this contract until an executed purchase order is received from the AEPA Member Agency or Participating Entities. The intent of this contract is to constitute the final and complete agreement between the AEPA Member Agency and Bidder Partner, and no other agreements, oral or otherwise, regarding the subject matter of this contract, shall bind any of the parties hereto. No change or modification of this contract shall be valid unless in writing and signed by both parties to this contract. If any provision of this contract is deemed invalid or illegal by any appropriate court of law, the remainder of this contract shall not be affected thereby. The initial term of this contract shall be for up to fifteen (15) months and will commence on the date indicated below and continue until February 28, 2021, unless terminated, canceled or extended. By mutual written agreement as warranted, the contract may be extended month by month up to six (6) months or for three (3) additional 12-month periods.

Awarding Agency	<u>Cooperative Purchasing Connection</u>	DocuSigned by:	<u>[Signature]</u>
Authorized Representative	<u>Jane Eastes, Deputy Director</u>		<u>6D9BB132BB3040A...</u>
Awarded this	<u>2nd</u>	day of	<u>January, 2020</u>
Contract to commence		Contract Number	<u>020-E</u>
(Member Agency to select)	<u>January 6, 2020</u>	Or	<u>-----March 1, 2020</u>



Association of Educational
PURCHASING AGENCIES

Acceptance of Bid & Contract Award

Instructions: PART I of this form is to be completed by the Bidder and signed by its Authorized Representative. PART II will be completed by the AEPA Member Agency only upon the occasion of the bid award. If approved by AEPA, the Bidder is required to produce a copy of the document for each of the AEPA Member Agency with which it contracts.

PART I: BIDDER

In compliance with the Invitation for Bid (IFB), the undersigned warrants that I/we have examined all Instructions to Bidders, associated documents, and being familiar with all of the conditions of the bid, hereby offer and agree to furnish all labor, materials, supplies and equipment incurred in compliance with all terms, conditions, specifications and amendments associated with this IFB and any written exceptions to the bid. Signature also certifies understanding and compliance with the certification requirements of the AEPA Member Agency's Terms and Conditions and/or Special Terms and Conditions. The undersigned understands that their competence, ability, capacity and obligations to offer and provide the proposed tangible personal property, professional services, construction services and other services on behalf of the Bidder Partner as well as other factors of interest to the AEPA Member Agency as stated in the evaluation section, will be a consideration in making the award.

Business Name	<u>Husquarna Professional Products</u>	Date	<u>9/12/2019</u>
Address	<u>9335 Harris Corners Pkwy #500</u>	City, State Zip	<u>Charlotte, NC, 28269</u>
Contact Person	<u>Jacob Breig</u>	Title	<u>Government Sales Manager</u>
Authorized Signature	<u><i>Jeff Newby</i></u>	Title	<u>VP Sales VP</u>
Email	<u>jake.breig@husquarnagroup.com</u>	Phone	<u>704-340-7367</u>

PART II: AWARDING MEMBER AGENCY

Your bid response for the above identified bid is hereby accepted. As a Bidder Partner you are now bound to offer and provide the products and services identified within this IFB, your response and approved by AEPA, including all terms, conditions, specifications, exceptions and amendments. As Bidder Partner, you are hereby not to commence any billable work or provide any products or services under this contract until an executed purchase order is received from the AEPA Member Agency or Participating Entities. The intent of this contract is to constitute the final and complete agreement between the AEPA Member Agency and Bidder Partner, and no other agreements, oral or otherwise, regarding the subject matter of this contract, shall bind any of the parties hereto. No change or modification of this contract shall be valid unless in writing and signed by both parties to this contract. If any provision of this contract is deemed invalid or illegal by any appropriate court of law, the remainder of this contract shall not be affected thereby. The initial term of this contract shall be for up to fifteen (15) months and will commence on the date indicated below and continue until February 28, 2021, unless terminated, canceled or extended. By mutual written agreement as warranted, the contract may be extended month by month up to six (6) months or for three (3) additional 12-month periods.

Awarding Agency	<u>North Dakota Educators Service Coop</u>		
Authorized Representative	<u><i>Robyn Schuler</i></u>		
Awarded this	<u>2</u>	day of <u>Jan</u>	<u>2020</u>
Contract to commence			Contract Number <u>020-E</u>
(Member Agency to select)	<u>January 6, 2020</u>	Or ----- <u>March 1, 2020</u>	